

AV RECEIVER/AV AMPLIFIER RX-V557/HTR-5850/DSP-AX557 RX-V457/HTR-5840/DSP-AX457 SERVICE MANUAL

IMPORTANT NOTICE

This manual has been provided for the use of authorized YAMAHA Retailers and their service personnel. It has been assumed that basic service procedures inherent to the industry, and more specifically YAMAHA Products, are already known and understood by the users, and have therefore not been restated.

WARNING: Failure to follow appropriate service and safety procedures when servicing this product may result in personal injury, destruction of expensive components, and failure of the product to perform as specified. For these reasons, we advise all YAMAHA product owners that any service required should be performed by an authorized YAMAHA Retailer or the appointed service representative.

IMPORTANT: The presentation or sale of this manual to any individual or firm does not constitute authorization, certification or recognition of any applicable technical capabilities, or establish a principle-agent relationship of any form.

The data provided is believed to be accurate and applicable to the unit(s) indicated on the cover. The research, engineering, and service departments of YAMAHA are continually striving to improve YAMAHA products. Modifications are, therefore, inevitable and specifications are subject to change without notice or obligation to retrofit. Should any discrepancy appear to exist, please contact the distributor's Service Division.

WARNING: Static discharges can destroy expensive components. Discharge any static electricity your body may have accumulated by grounding yourself to the ground buss in the unit (heavy gauge black wires connect to this buss).

IMPORTANT: Turn the unit OFF during disassembly and part replacement. Recheck all work before you apply power to the unit.

■ CONTENTS

TO SERVICE PERSONNEL	2	AMP ADJUSTMENT / アンプ部調整	45
FRONT PANELS	3~6	IC DATA	46~51
REAR PANELS	6~15	BLOCK DIAGRAM	52~55
SPECIFICATIONS / 参考仕様	16~18	DISPLAY DATA	56
INTERNAL VIEW	18~19	PRINTED CIRCUIT BOARD	57~79
REMOTE CONTROL PANELS	19	PIN CONNECTION DIAGRAM	80
DISASSEMBLY PROCEDURES / 分解手順	20~23	SCHEMATIC DIAGRAM	81~93
SELF DIAGNOSIS FUNCTION (DIAG) /		PARTS LIST	95~129
自己診断機能 (ダイアグ)	24~44	REMOTE CONTROL	130~131



このサービスマニュアルは、エコマーク認定の再生紙を使用しています。
 This Service Manual uses recycled paper.

100941

Copyright 2005 YAMAHA CORPORATION
 This manual is copyrighted by YAMAHA and may not be copied or
 redistributed either in print or electronically without permission.



YAMAHA

YAMAHA CORPORATION
 P.O.Box 1, Hamamatsu, Japan

'05.02

RX-V557/HTR-5850/DSP-AX557
RX-V457/HTR-5840/DSP-AX457

■ TO SERVICE PERSONNEL

1. Critical Components Information
Components having special characteristics are marked  and must be replaced with parts having specifications equal to those originally installed.
2. Leakage Current Measurement (For 120V Models Only)
When service has been completed, it is imperative to verify that all exposed conductive surfaces are properly insulated from supply circuits.
 - Meter impedance should be equivalent to 1500 ohms shunted by 0.15μF.
 - Leakage current must not exceed 0.5mA.
 - Be sure to test for leakage with the AC plug in both polarities.

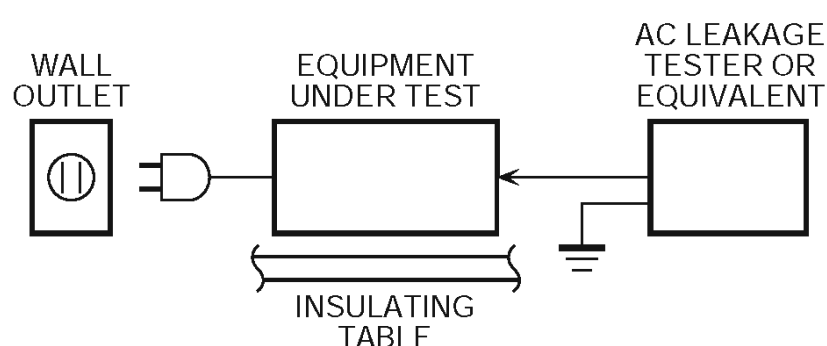

“CAUTION”

“F1, 2: FOR CONTINUED PROTECTION AGAINST RISK OF FIRE, REPLACE ONLY WITH SAME TYPE 8A, 125V FUSE.”

CAUTION

F1, 2: REPLACE WITH SAME TYPE 8A, 125V FUSE.

ATTENTION

F1, 2: UTILISER UN FUSIBLE DE RECHANGE DE MEME TYPE DE 8A, 125V.

WARNING: CHEMICAL CONTENT NOTICE!

The solder used in the production of this product contains LEAD. In addition, other electrical/electronic and/or plastic (where applicable) components may also contain traces of chemicals found by the California Health and Welfare Agency (and possibly other entities) to cause cancer and/or birth defects or other reproductive harm.

DO NOT PLACE SOLDER, ELECTRICAL/ELECTRONIC OR PLASTIC COMPONENTS IN YOUR MOUTH FOR ANY REASON WHATSOEVER!

Avoid prolonged, unprotected contact between solder and your skin! When soldering, do not inhale solder fumes or expose eyes to solder/flux vapor!

If you come in contact with solder or components located inside the enclosure of this product, wash your hands before handling food.

About Lead Free Solder / 無鉛ハンダについて

The P.C.B.s installed in this unit are soldered using the following solder.

本機に搭載されている基板のハンダ付けに使用されているハンダは下記の通りです。

	Component Side / 部品面	Foil Side / ハンダ面
DSP P.C.B.	Lead Solder / 鉛入りハンダ	Lead Free Solder / 無鉛ハンダ
FUNCTION P.C.B.	—	Lead Free Solder / 無鉛ハンダ
OPERATION P.C.B.	—	Lead Free Solder / 無鉛ハンダ
MAIN P.C.B.	—	Lead Free Solder / 無鉛ハンダ
POWER P.C.B.	—	Lead Free Solder / 無鉛ハンダ
SUBTRANS P.C.B.	—	Lead Free Solder / 無鉛ハンダ
CONVERSION P.C.B.	Lead Solder / 鉛入りハンダ	Lead Free Solder / 無鉛ハンダ
VIDEO P.C.B.	—	Lead Free Solder / 無鉛ハンダ
XM P.C.B.	Lead Solder / 鉛入りハンダ	Lead Free Solder / 無鉛ハンダ

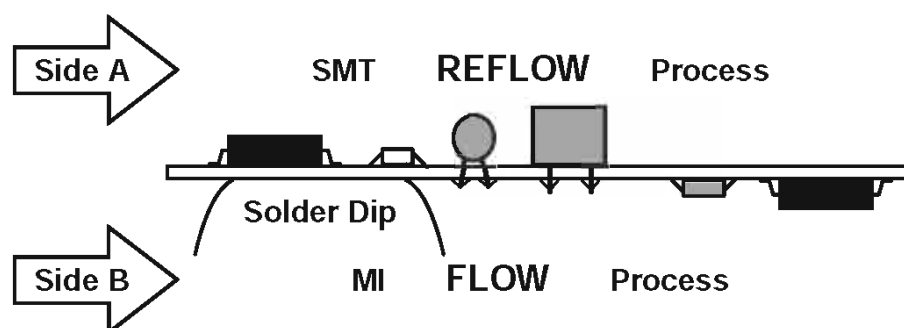

Among some types of lead free solder currently available, it is recommended to use one of the following types for the repair work.

- Sn + Ag + Cu (tin + silver + copper)
- Sn + Cu (tin + copper)
- Sn + Zn + Bi (tin + zinc + bismuth)

Caution:

1. As the melting point temperature of the lead free solder is about 30°C to 40°C (50°F to 70°F) higher than that of the lead solder, be sure to use a soldering iron suitable to each solder.
2. If lead solder must be used, be sure to remove lead free solder from each terminal section of the parts to be replaced and from the area around it completely before soldering, or make sure that the lead free solder and lead solder melt together fully.

無鉛ハンダにはいくつかの種類がありますが、修理時には下記のような無鉛ハンダの使用を推奨します。

- Sn+Ag+Cu(錫+銀+銅)
- Sn+Cu(錫+銅)
- Sn+Zn+Bi(錫+亜鉛+ビスマス)

注意：

- ① 無鉛ハンダの融点温度は通常の鉛入りハンダに比べ30～40°C程度高くなっていますので、それぞれのハンダに合ったハンダごてをご使用ください。
- ② 鉛入りハンダを使わざるを得ない場合は、あらかじめ交換する部品端子部やその周辺部の無鉛ハンダをすべて取り除くか、あるいは無鉛ハンダと鉛入りハンダが十分に溶けた状態となるようにハンダ付けしてください。

■ FRONT PANELS

RX-V557 (U, C models)

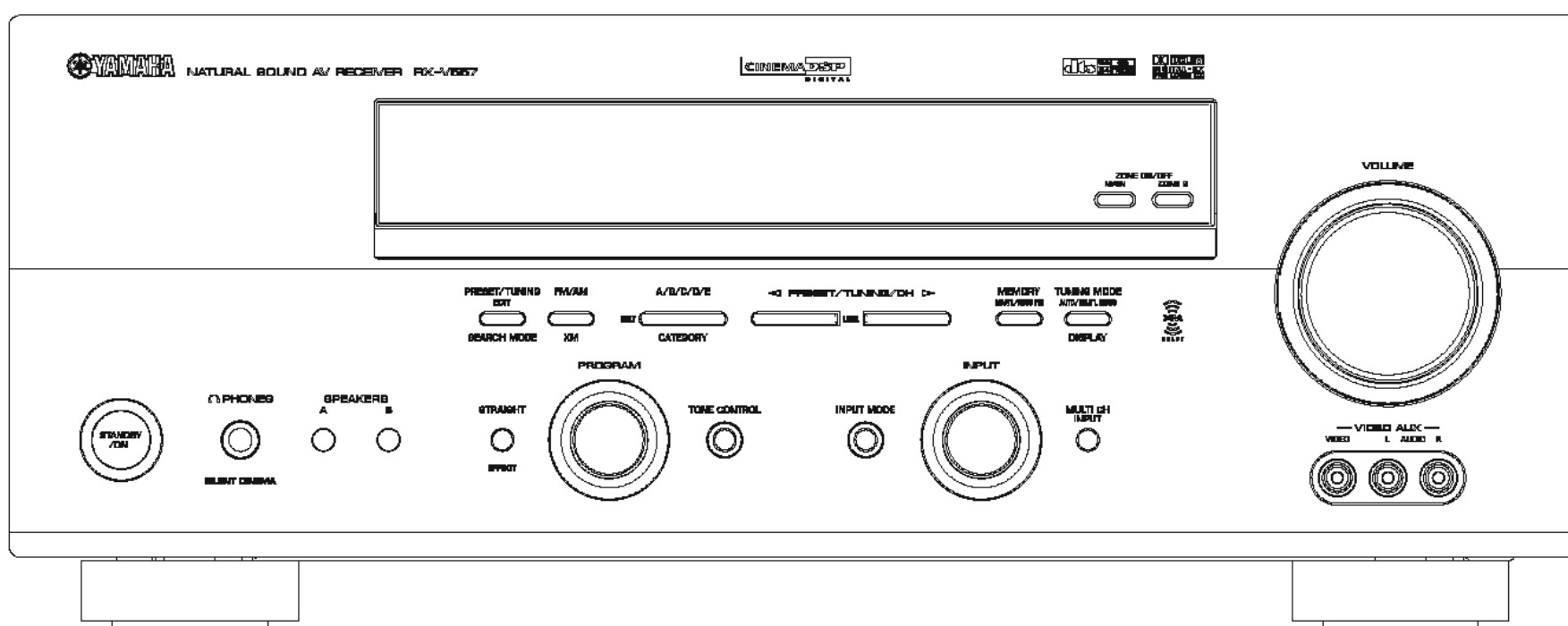

RX-V557 (R, T, K, A, B, G, E, L models)

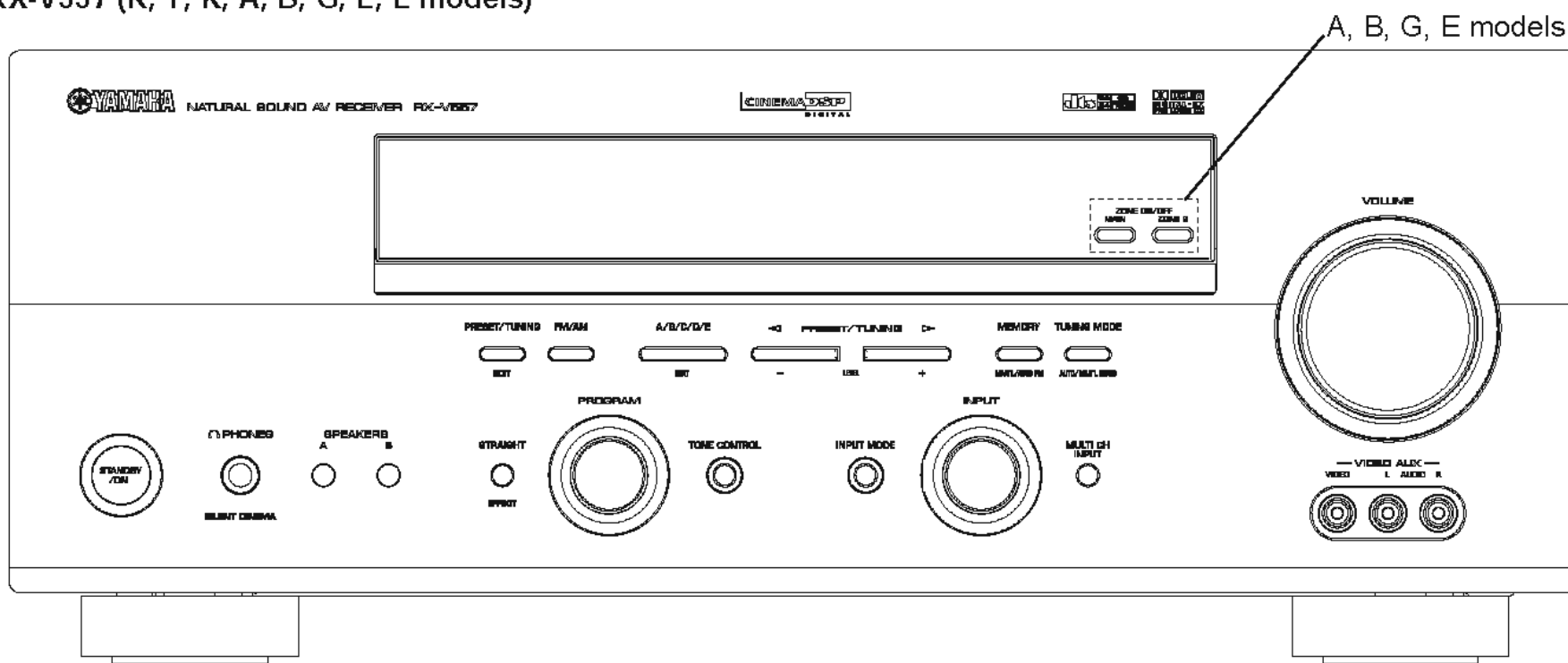

RX-V557/HTR-5850/DSP-AX557
 RX-V457/HTR-5840/DSP-AX457

HTR-5850 (U, C models)

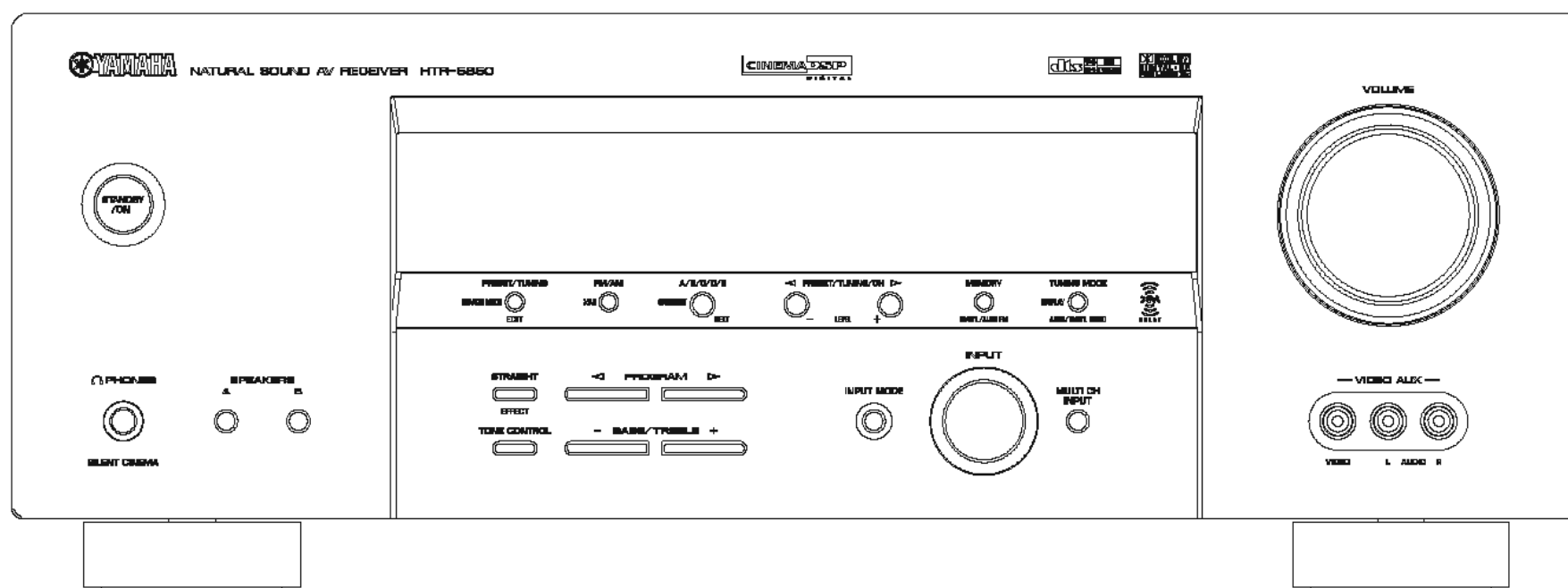

HTR-5850 (T, K, A models)

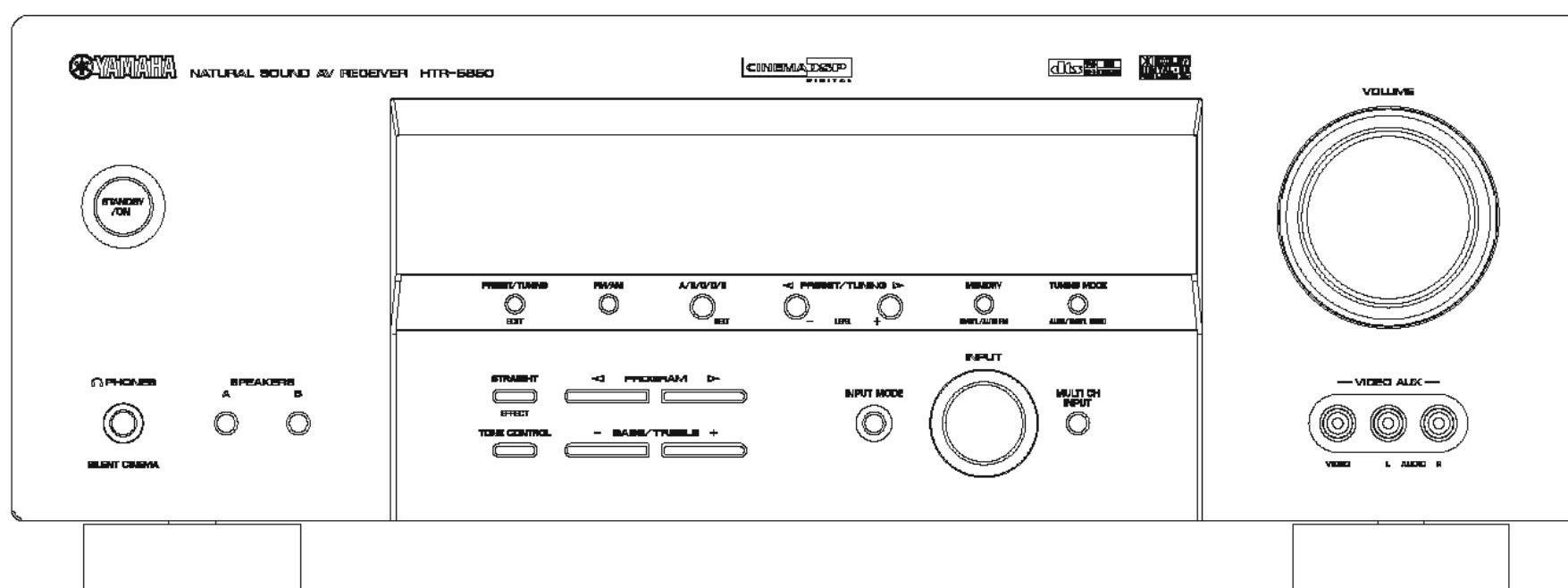

DSP-AX557 (J model)

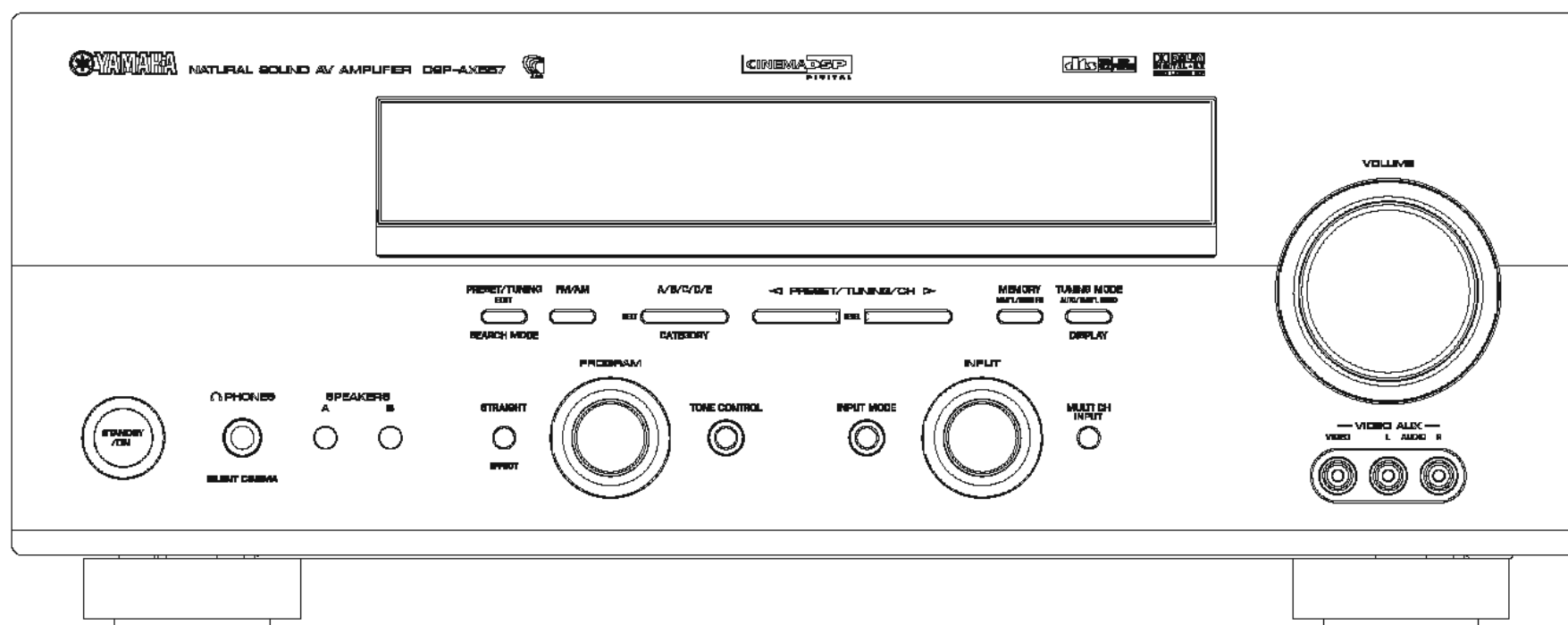

RX-V457 (U, C models)

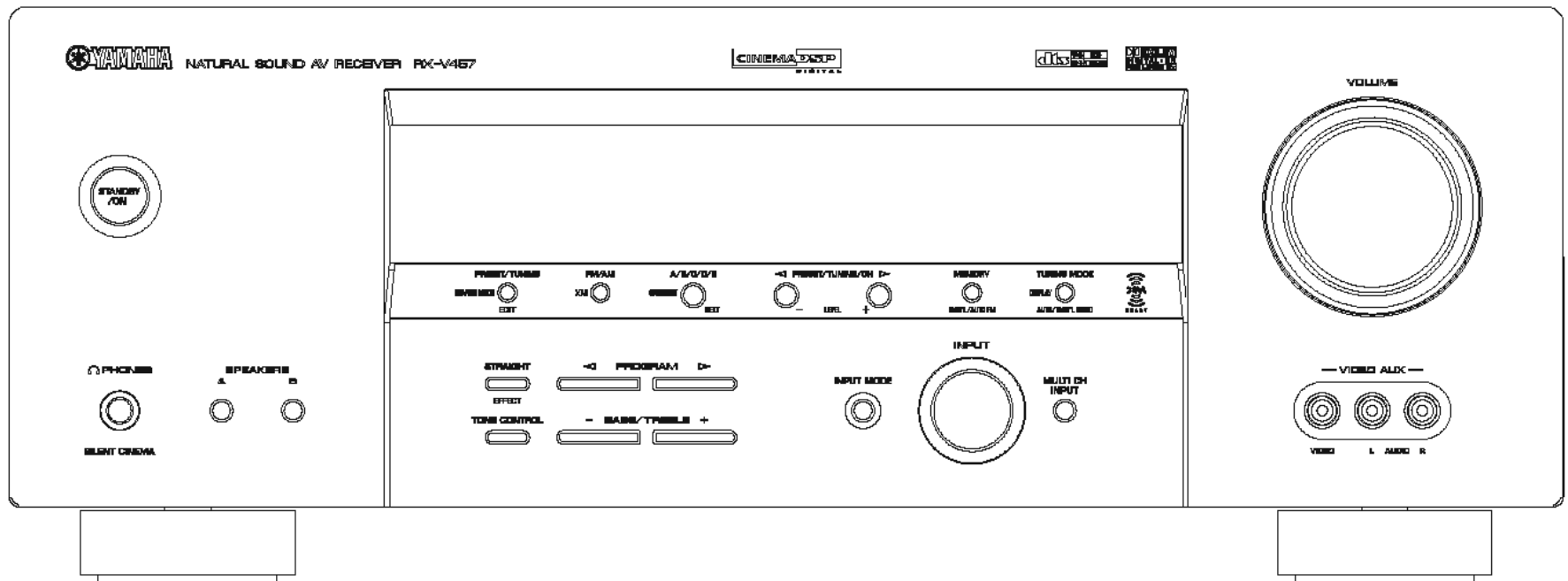

RX-V457 (R, T, K, A, B, G, E, L models)

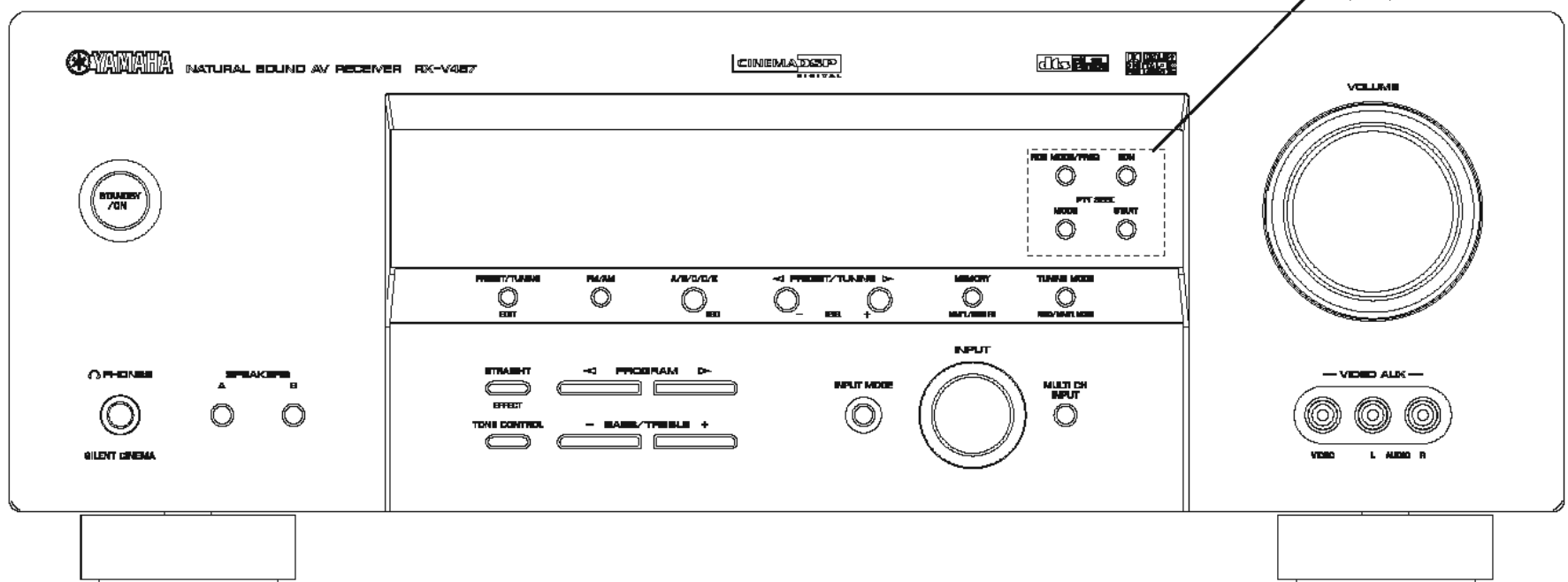

HTR-5840 (U, C models)

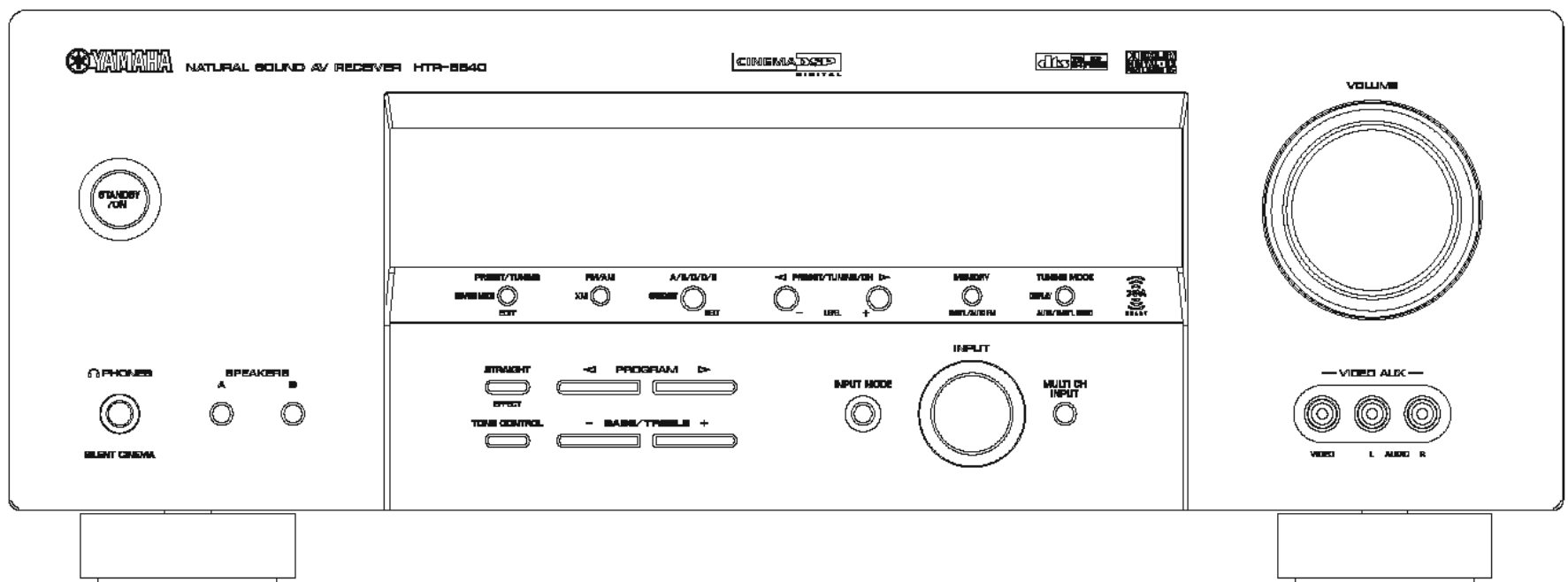

RX-V557/HTR-5850/DSP-AX557
RX-V457/HTR-5840/DSP-AX457

HTR-5840 (T, K, A, B, G, E models)

B, G, E models

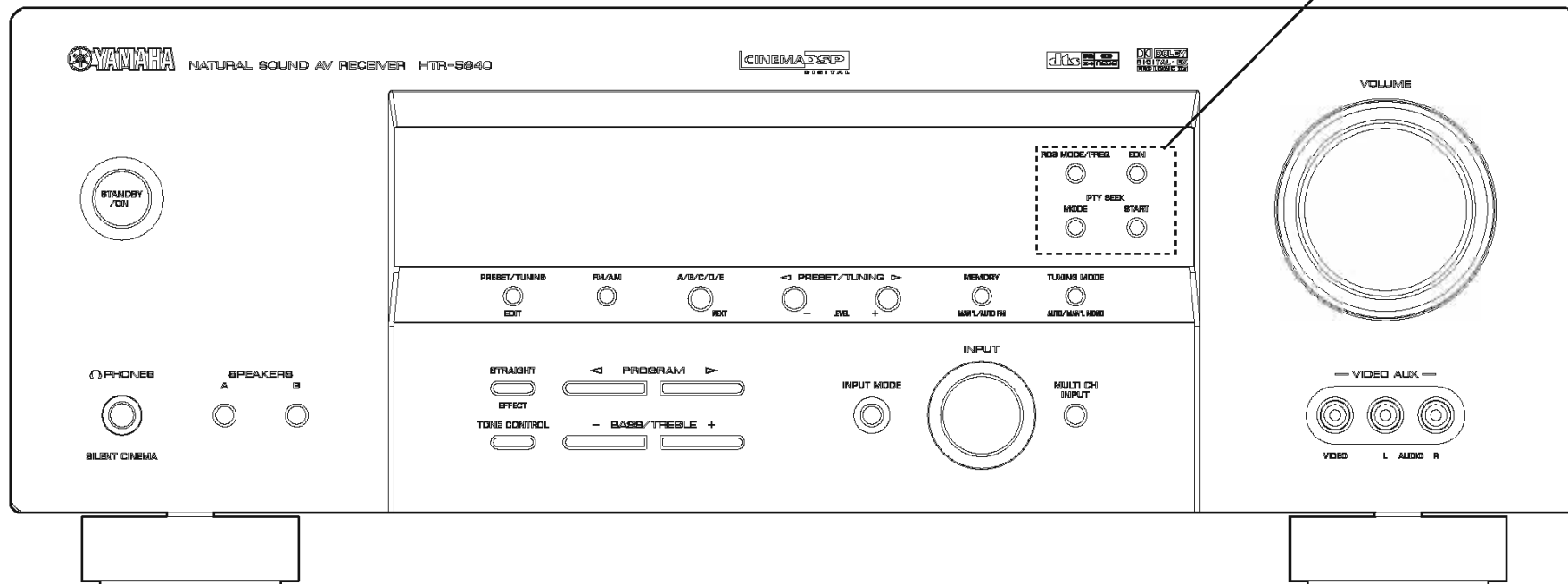

DSP-AX457 (J model)

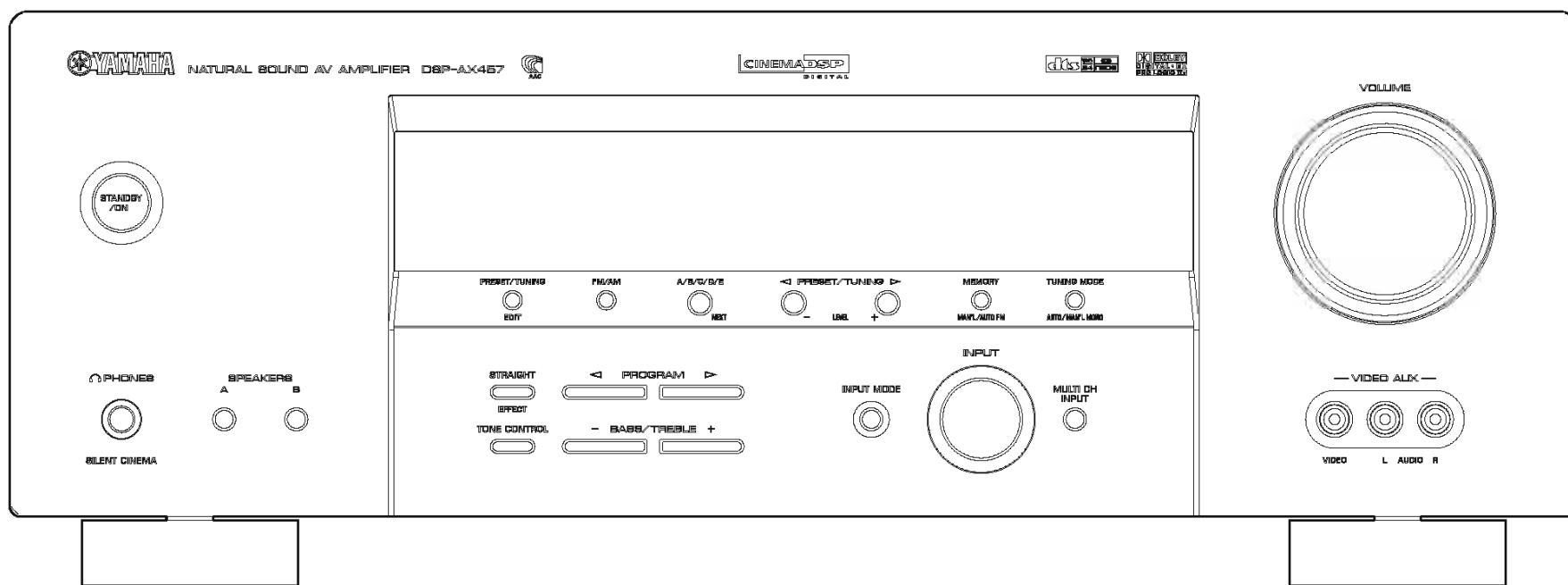

REAR PANELS

RX-V557 (U, C models)

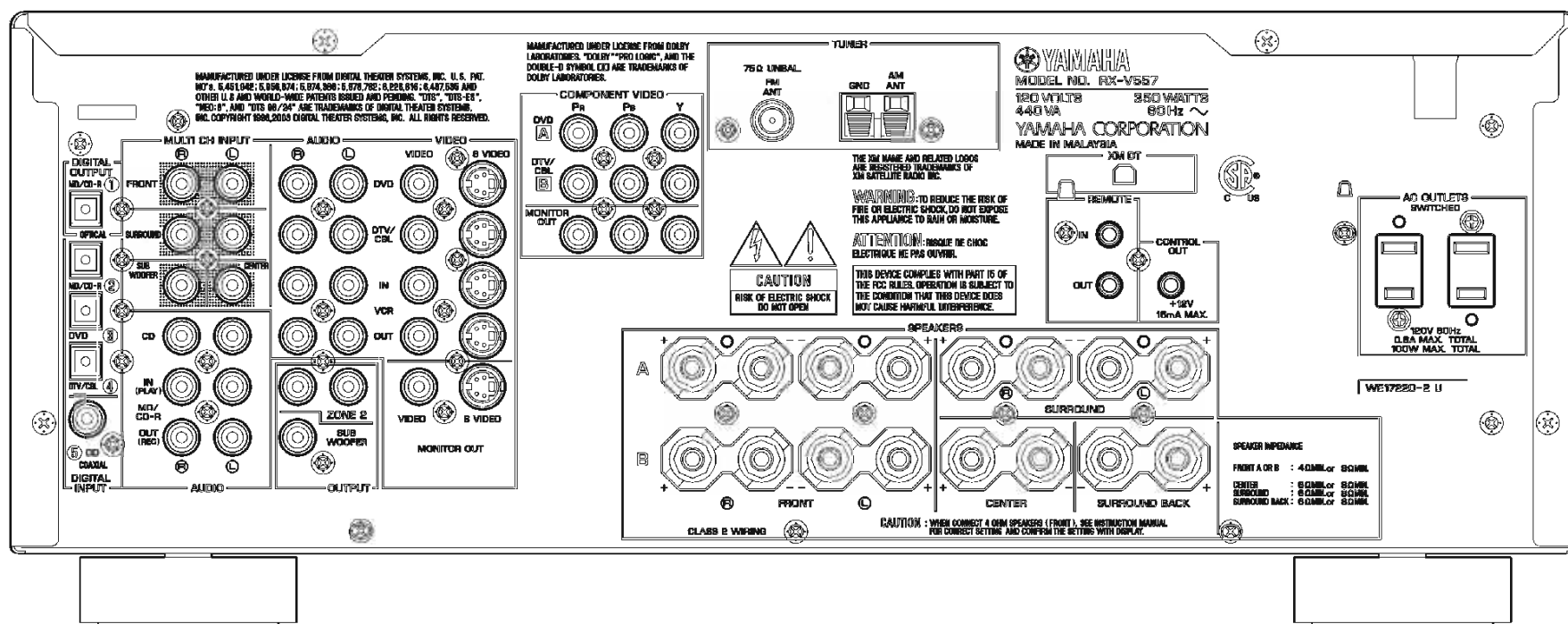

RX-V557 (R model)

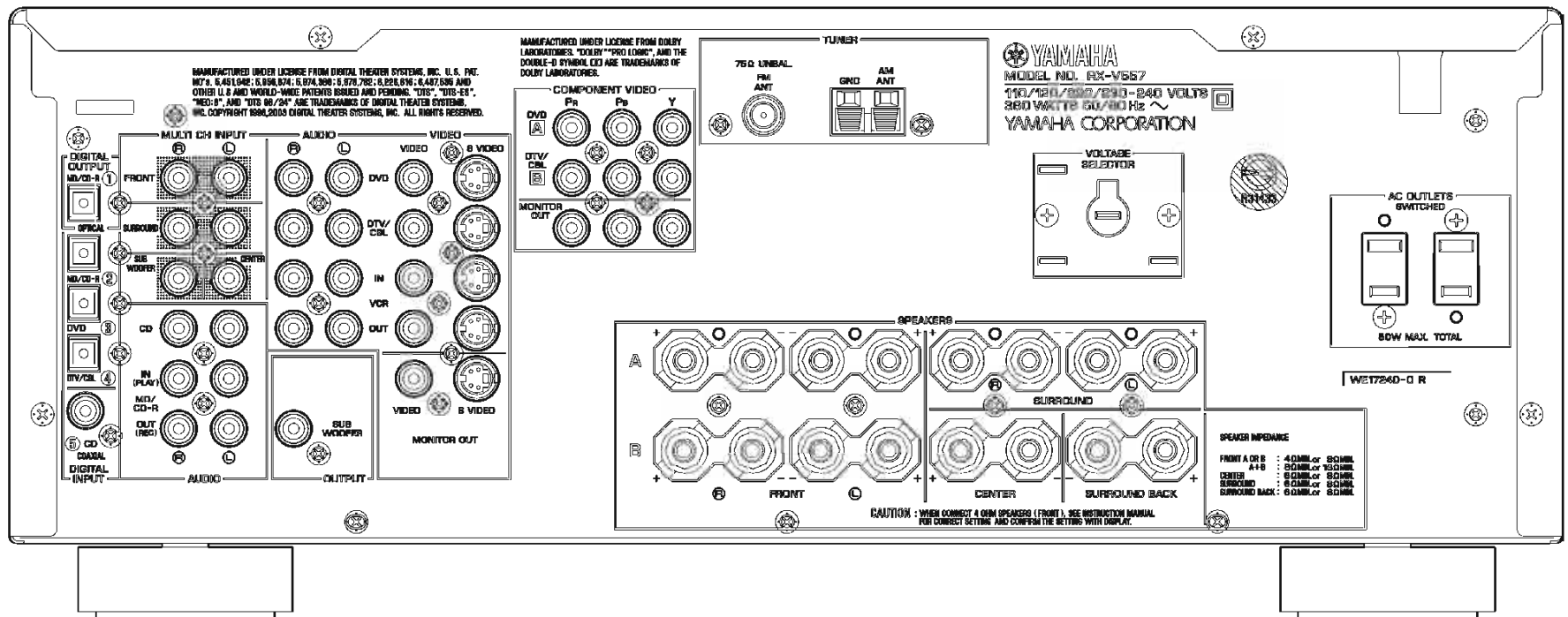

RX-V557 (T model)

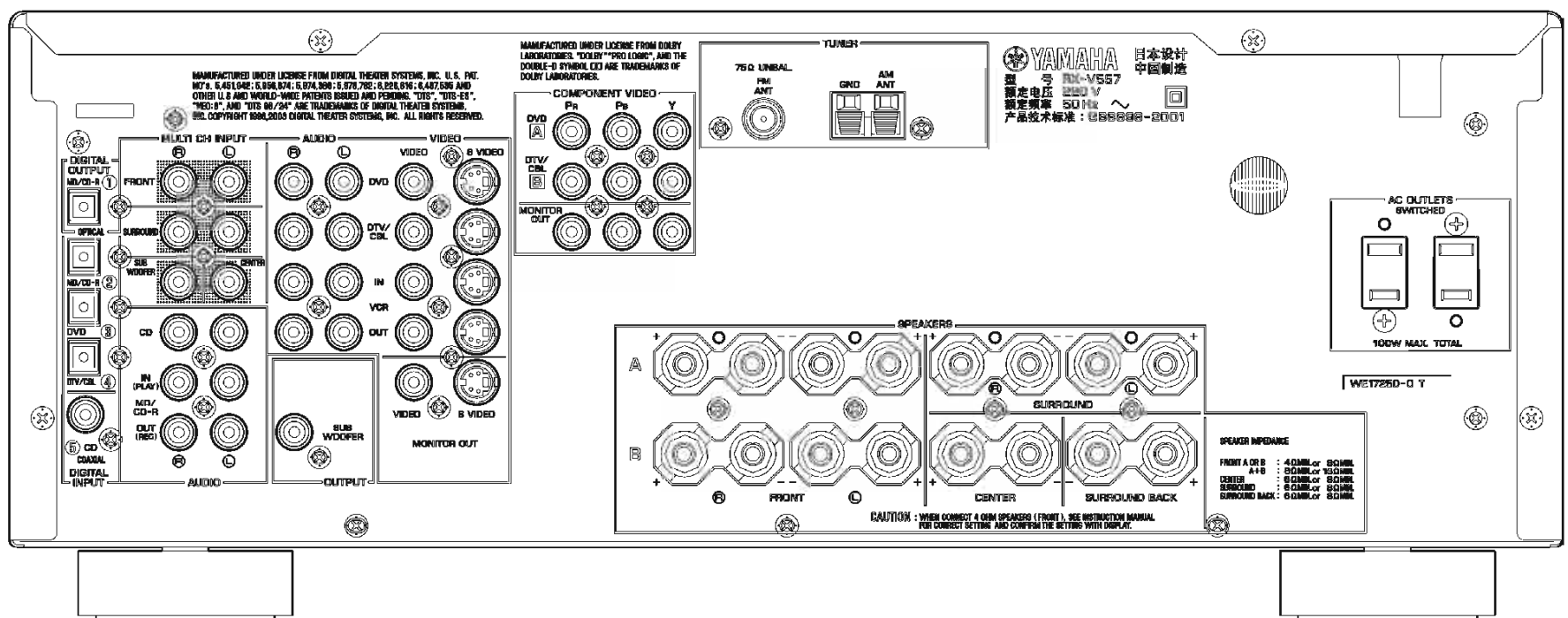

RX-V557 (K model)

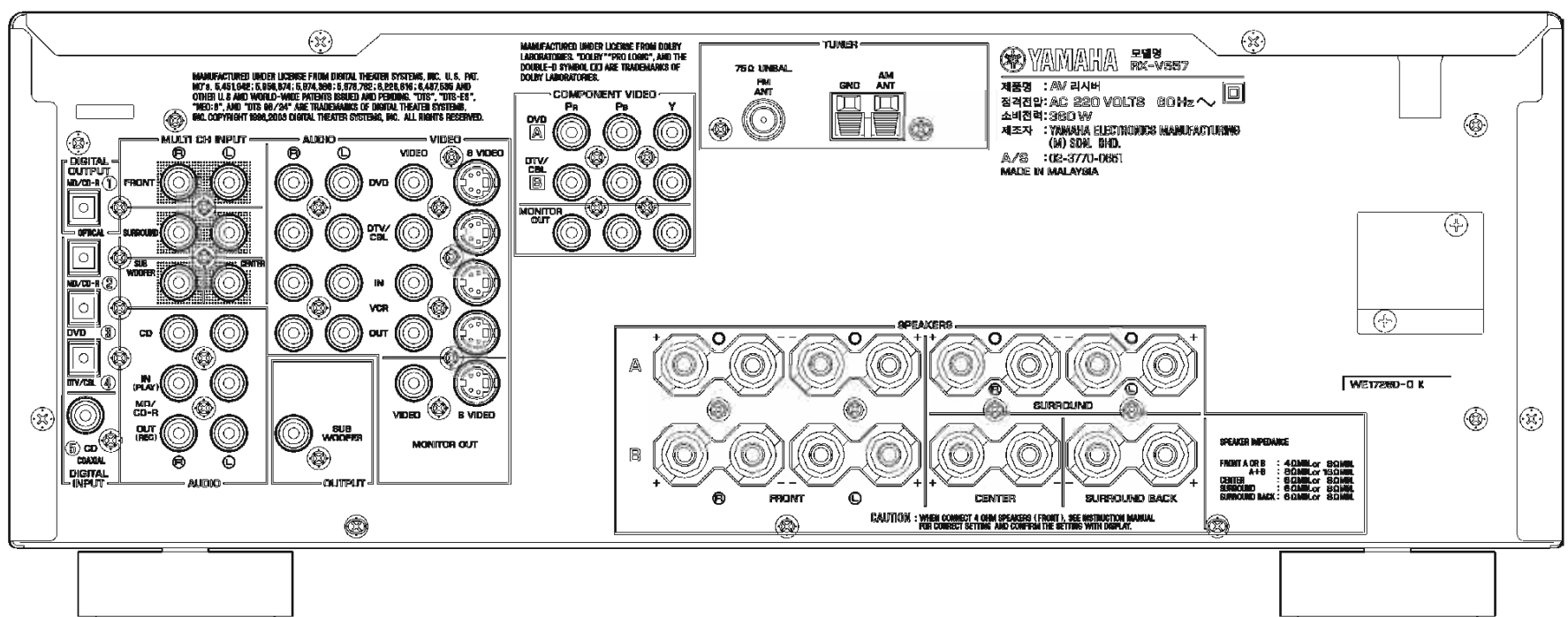

RX-V557/HTR-5850/DSP-AX557
 RX-V457/HTR-5840/DSP-AX457

RX-V557 (A model)

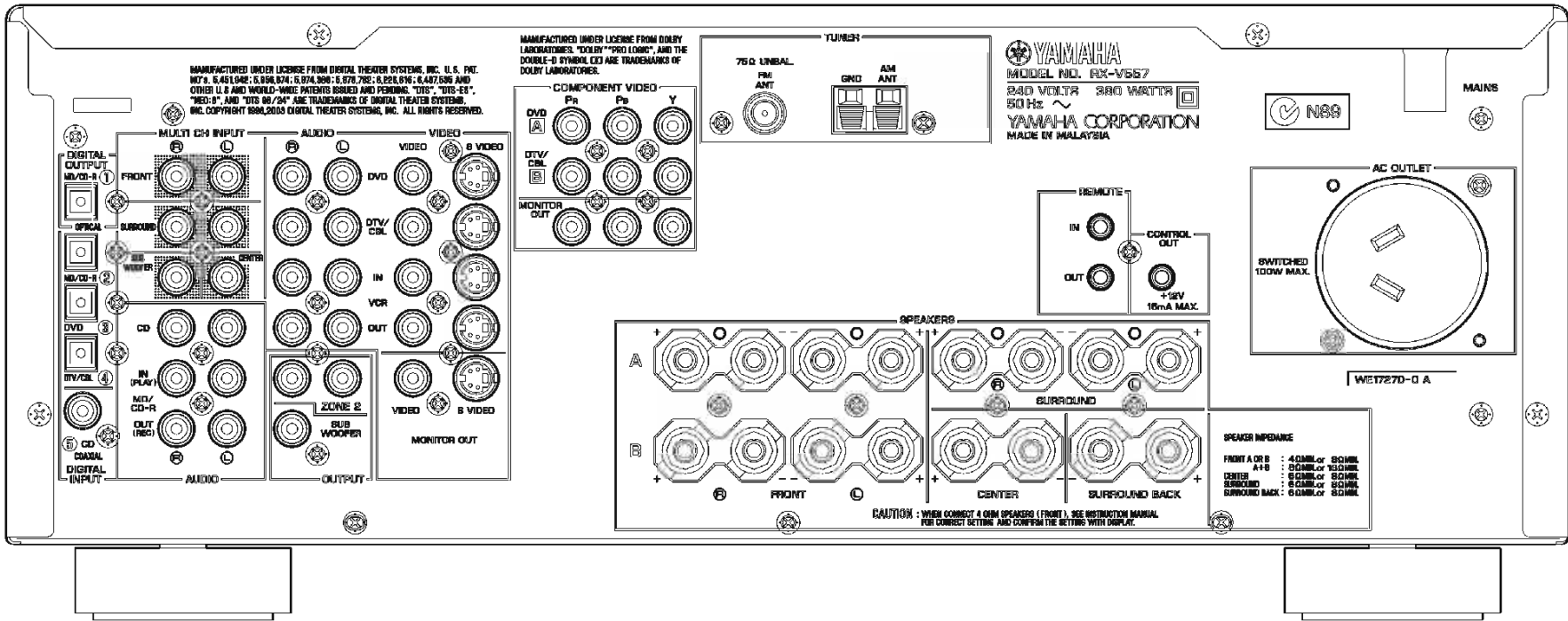

RX-V557 (B model)

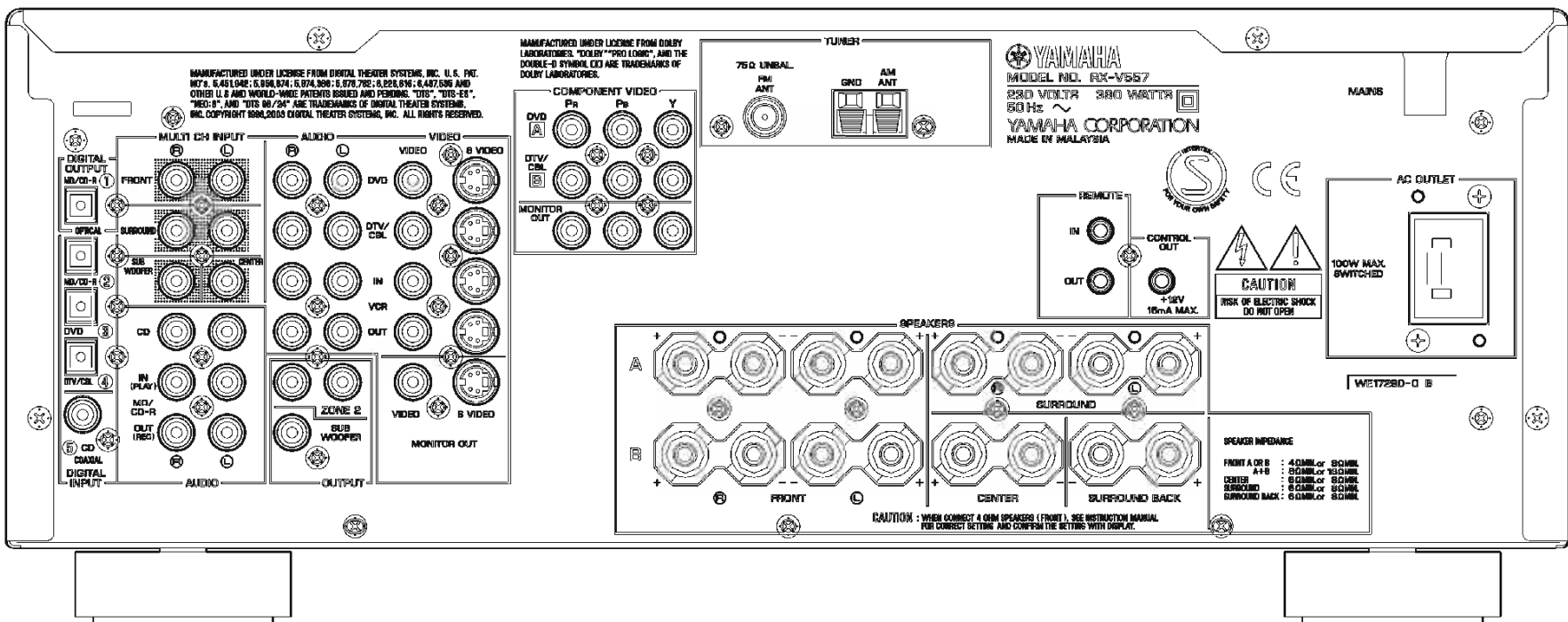

RX-V557 (G, E models)

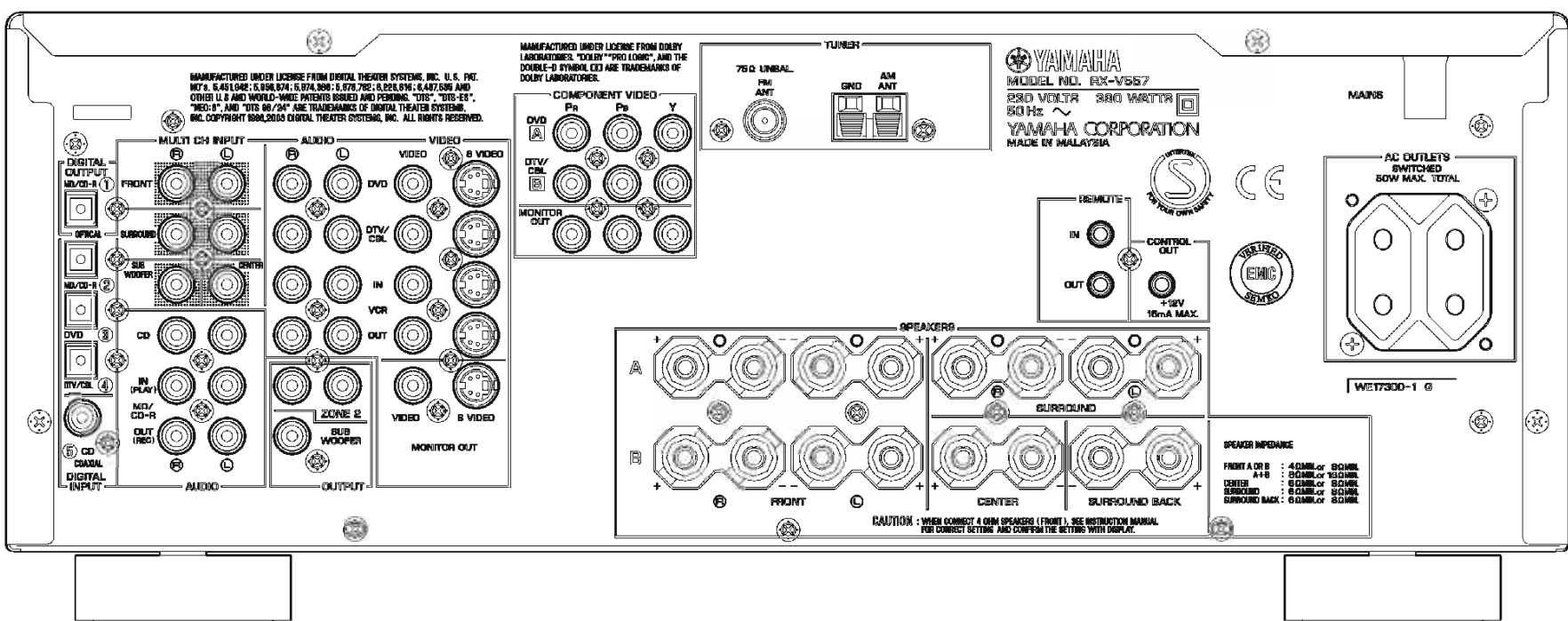

RX-V557 (L model)

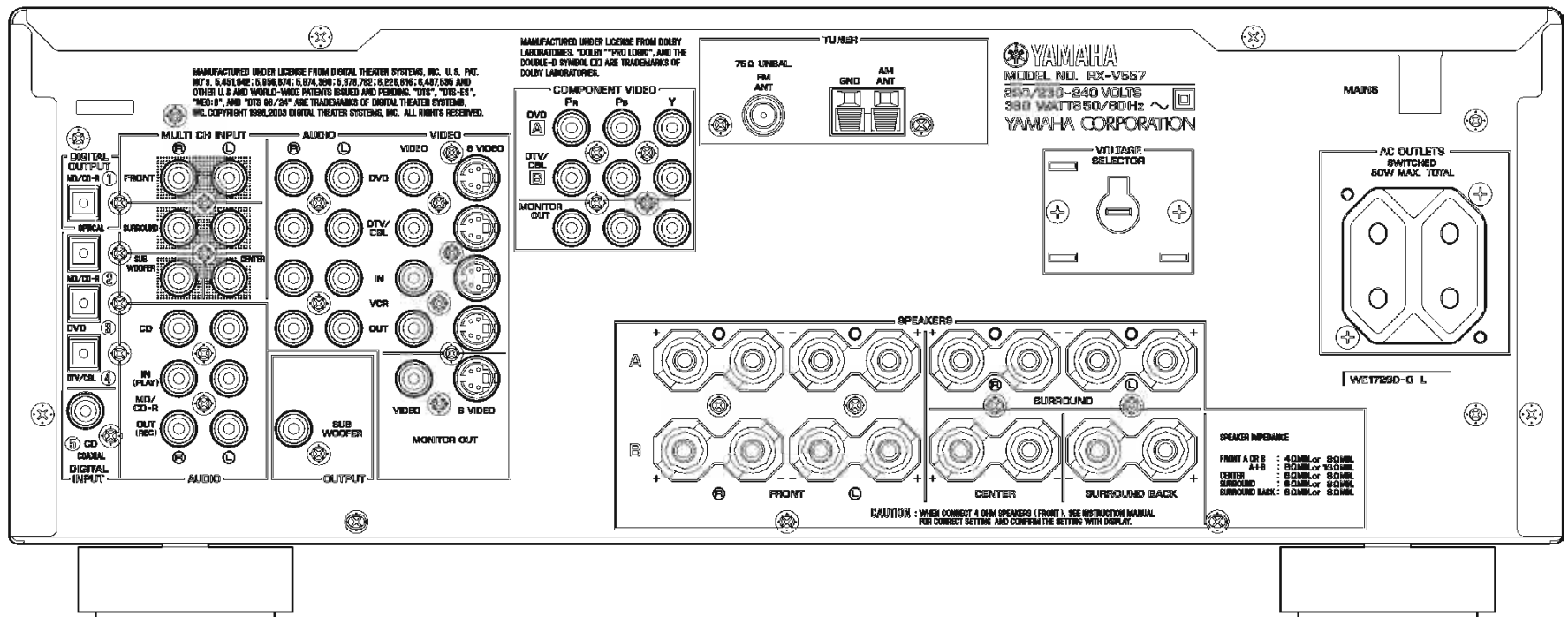

HTR-5850 (U, C models)

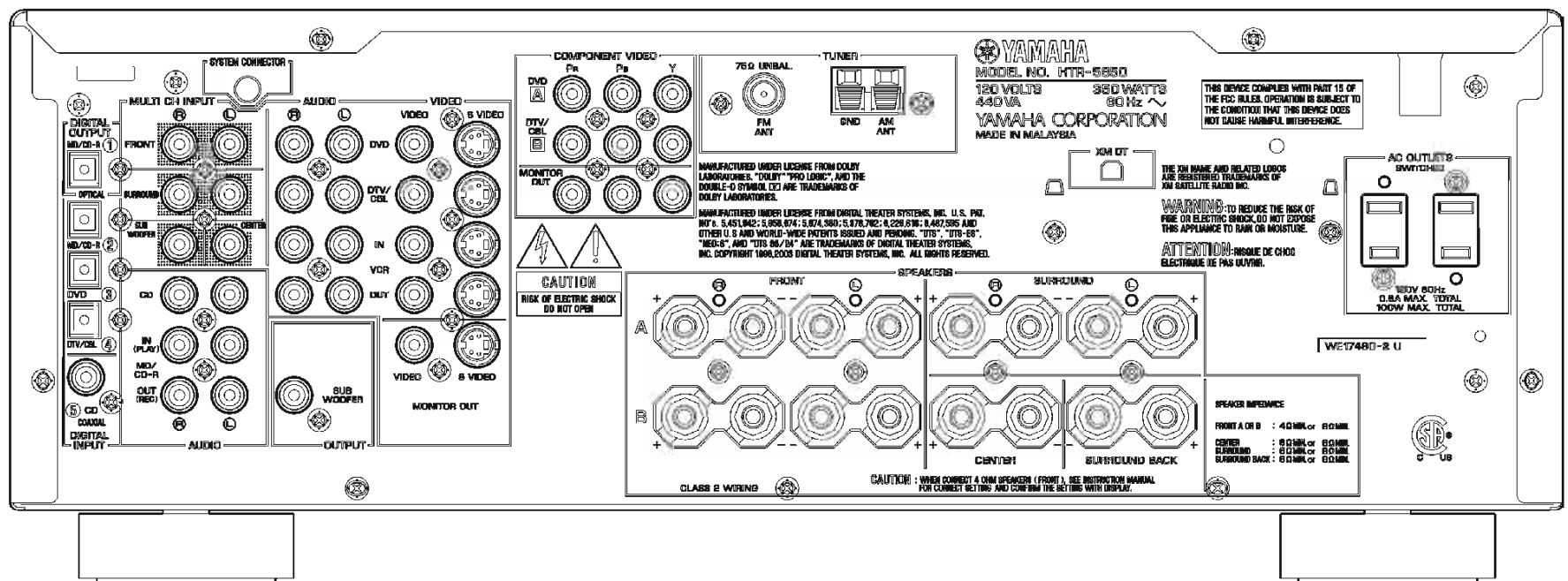

HTR-5850 (T model)

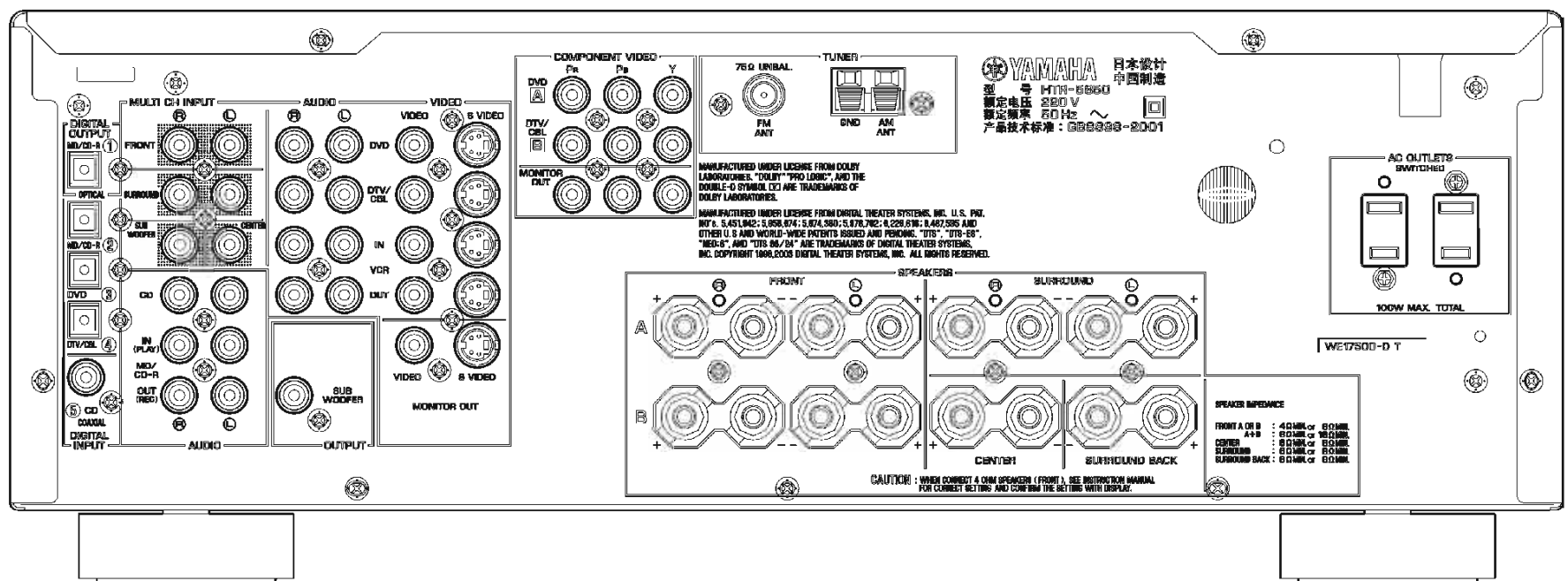

RX-V557/HTR-5850/DSP-AX557
RX-V457/HTR-5840/DSP-AX457

HTR-5850 (K model)

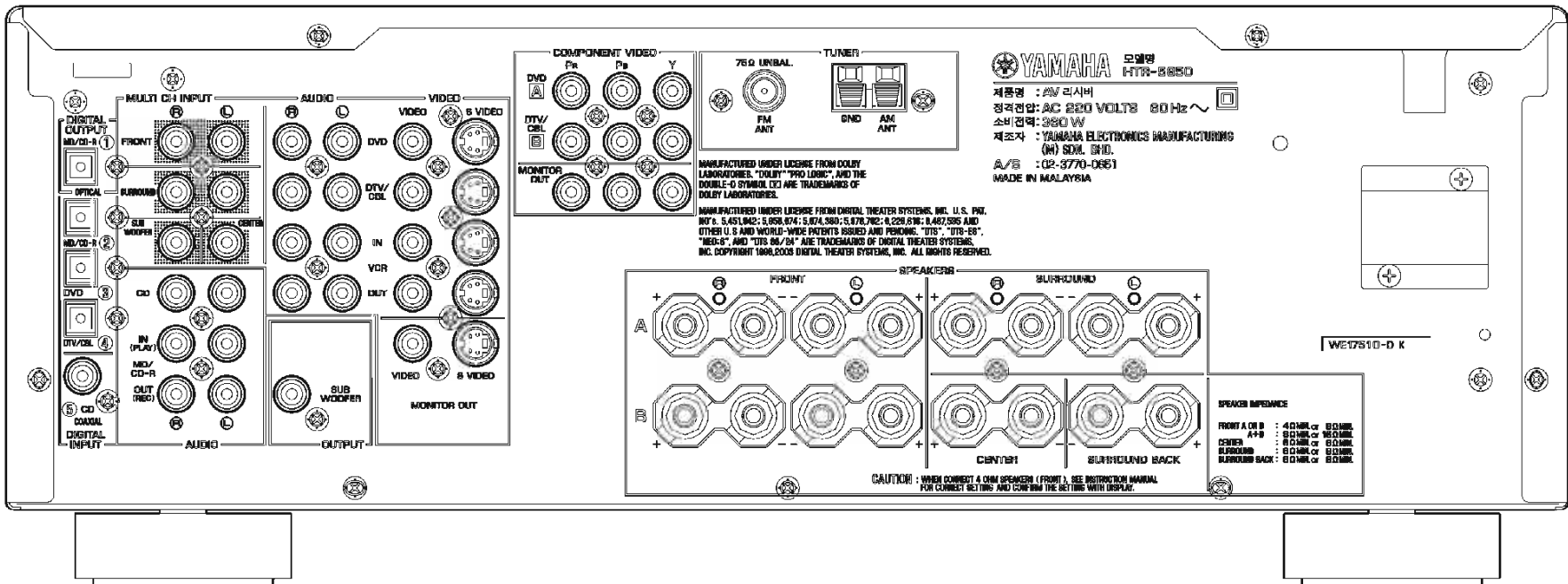

HTR-5850 (A model)

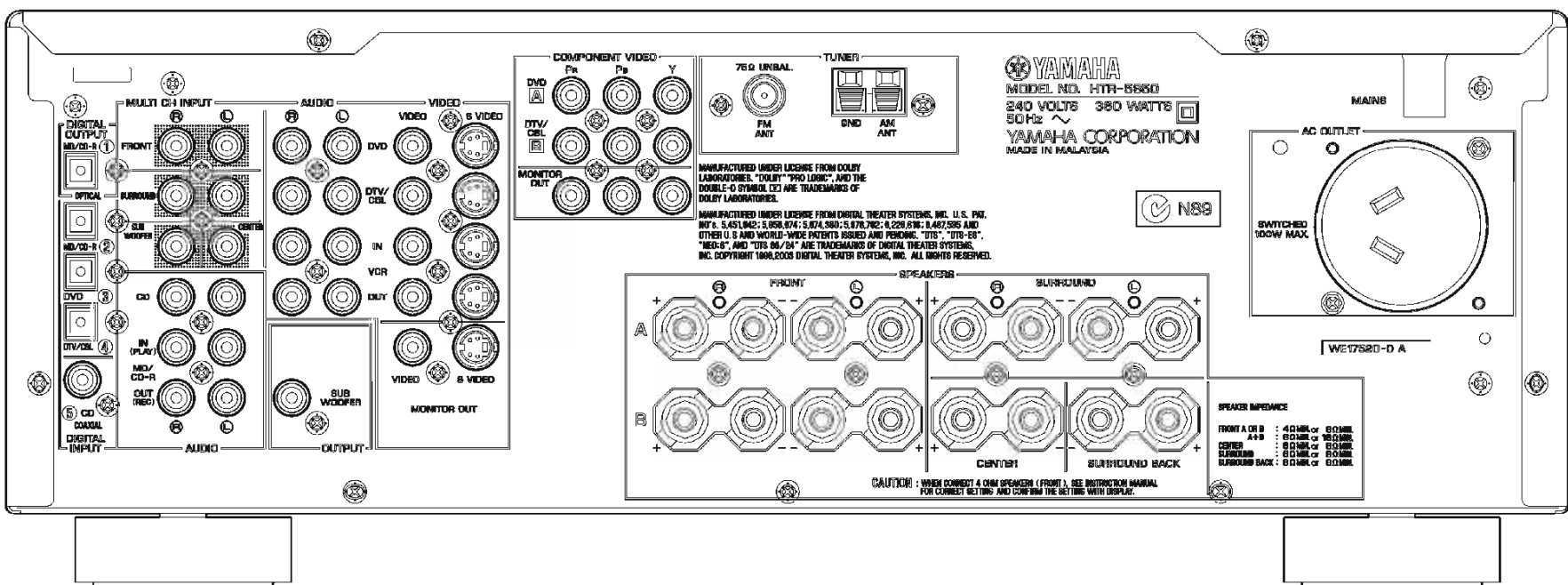

DSP-AX557 (J model)

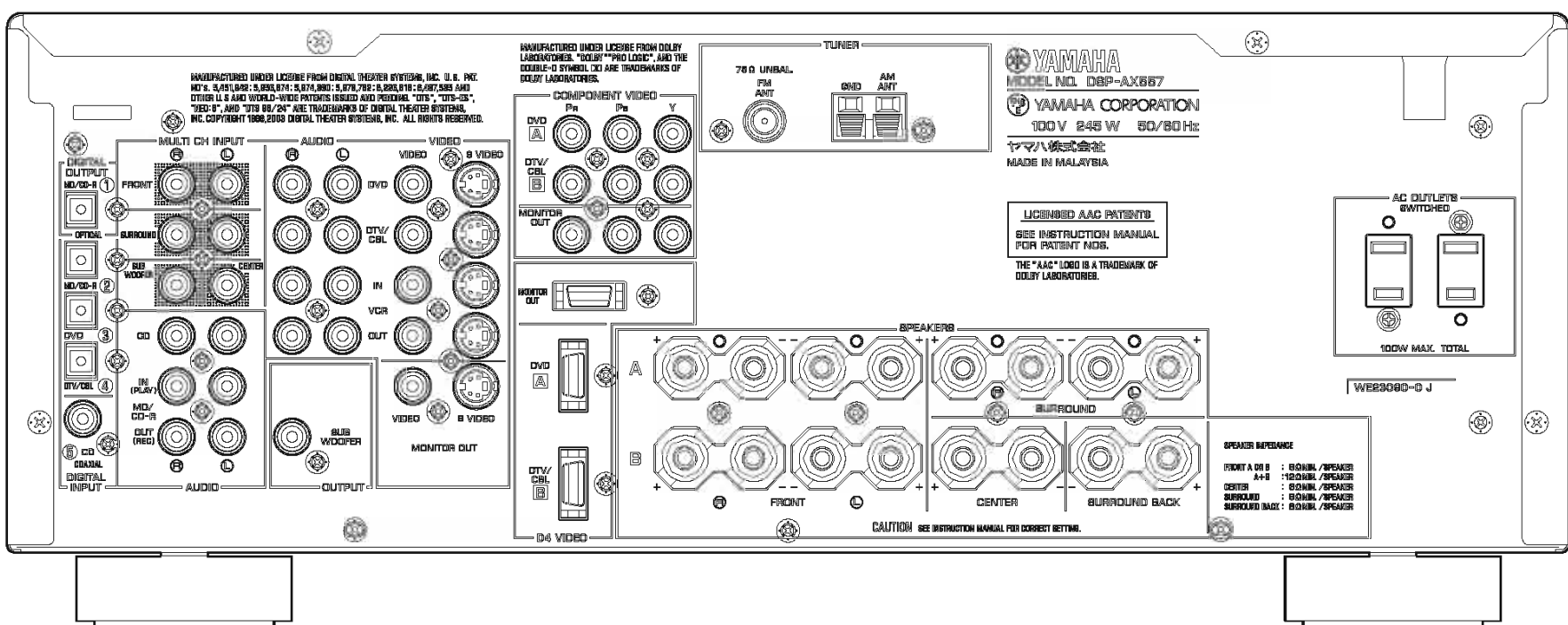

RX-V457 (U, C models)

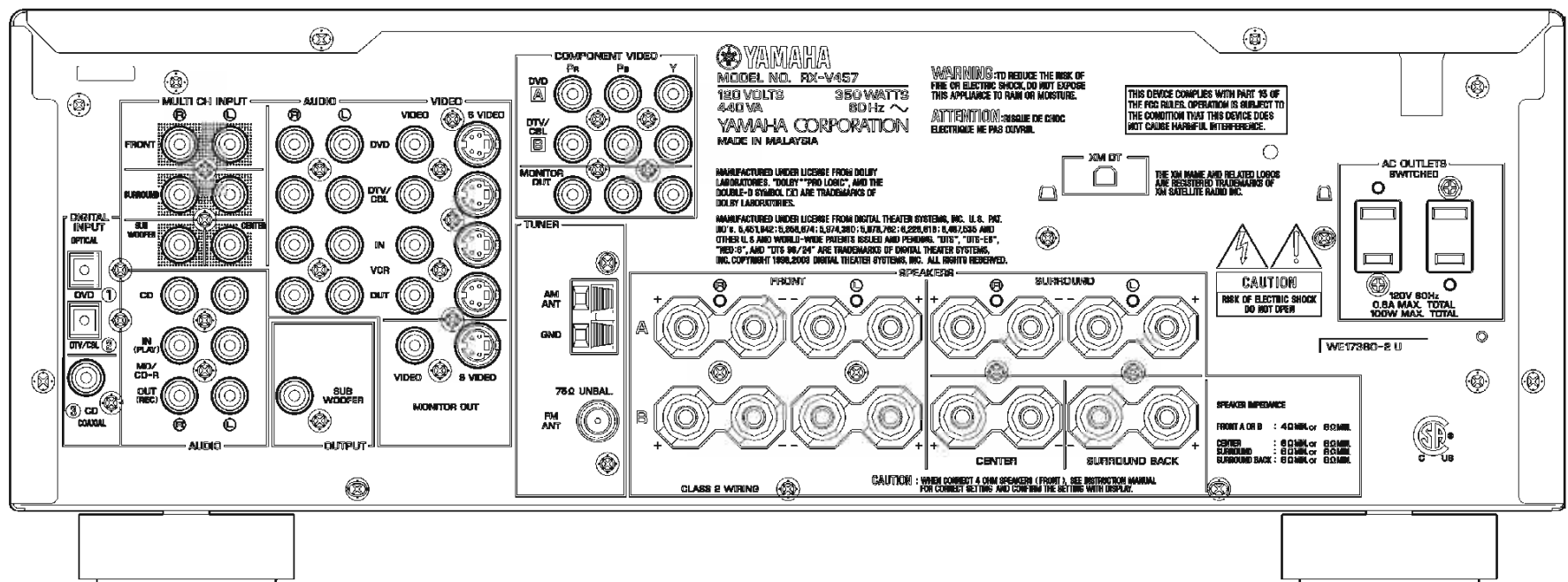

RX-V457 (R model)

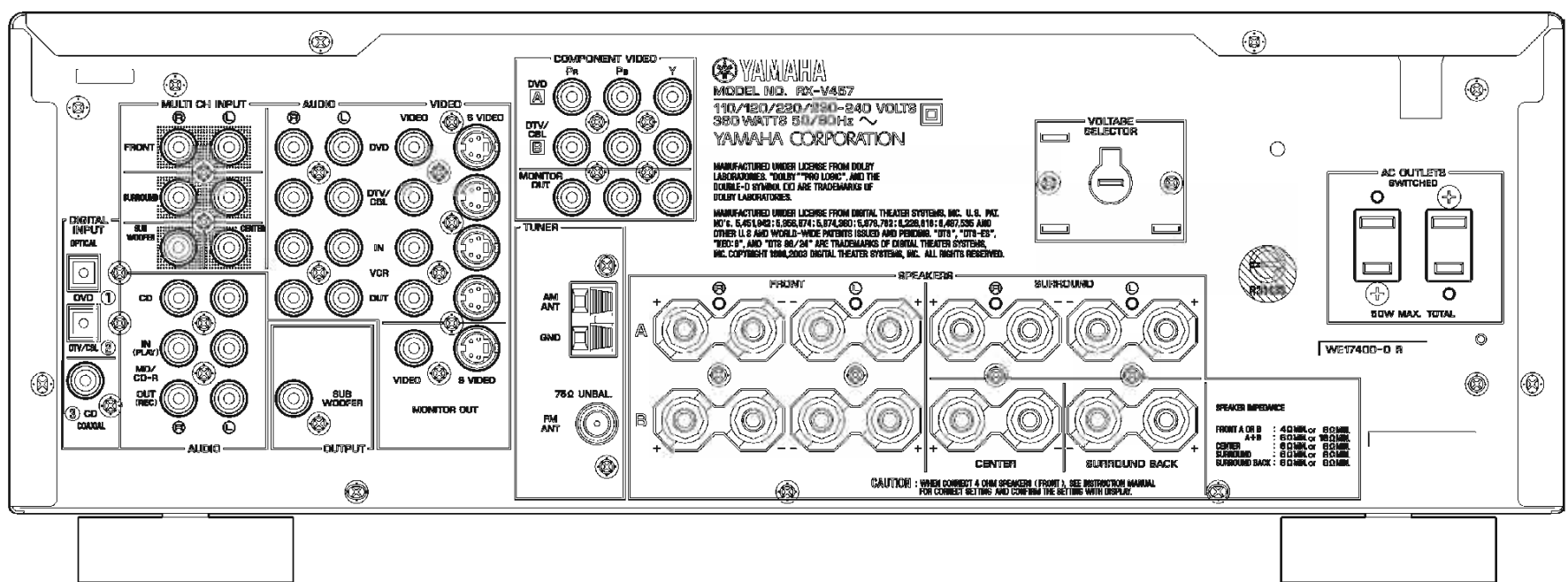

RX-V457 (T model)

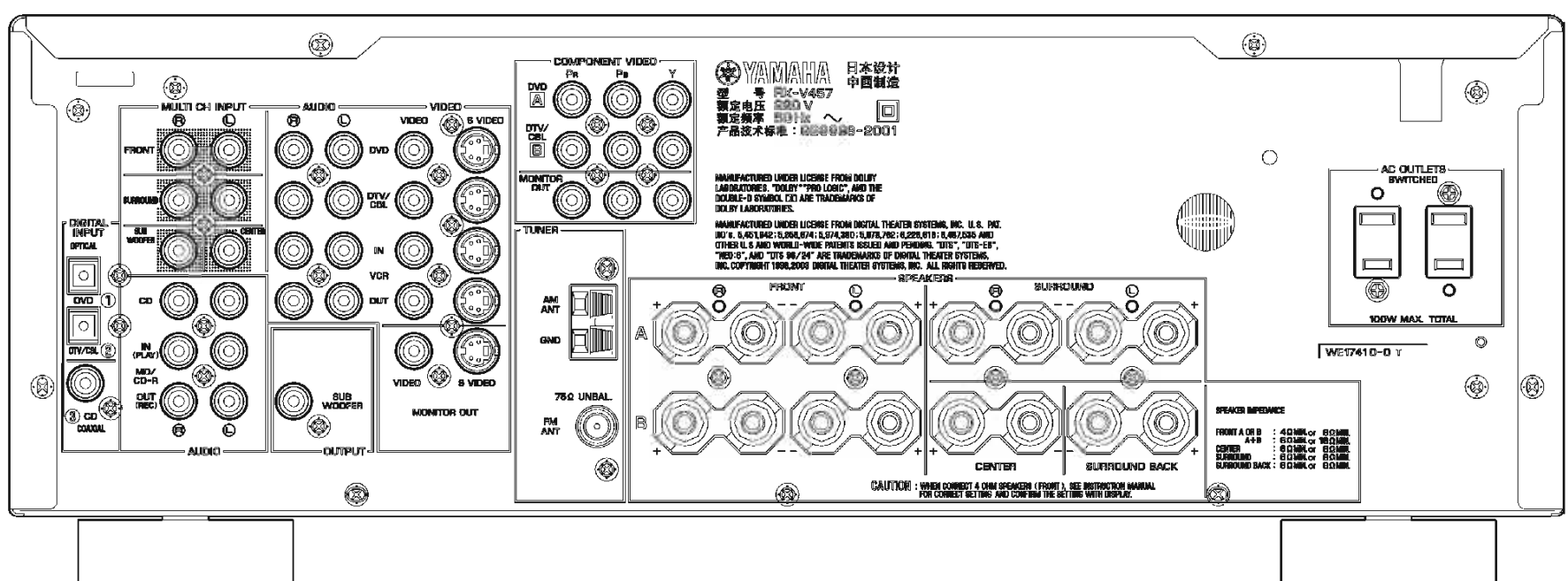

RX-V557/HTR-5850/DSP-AX557
RX-V457/HTR-5840/DSP-AX457

RX-V457 (K model)

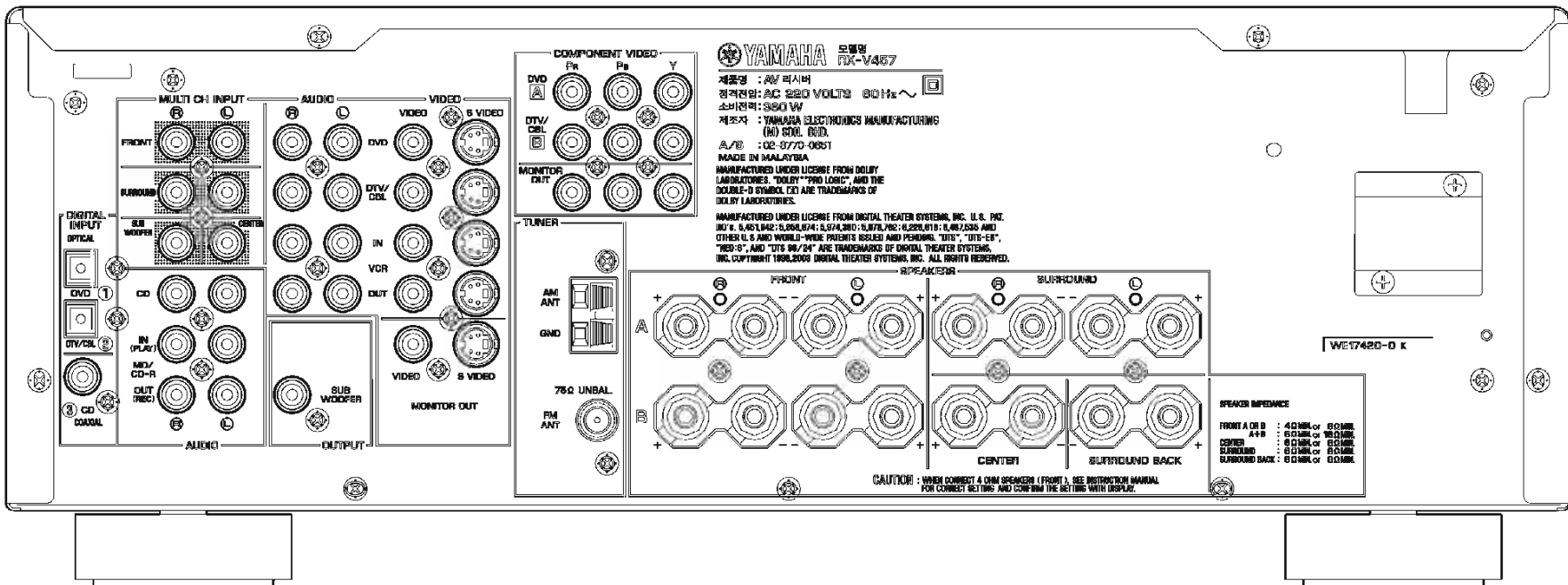

RX-V457 (A model)

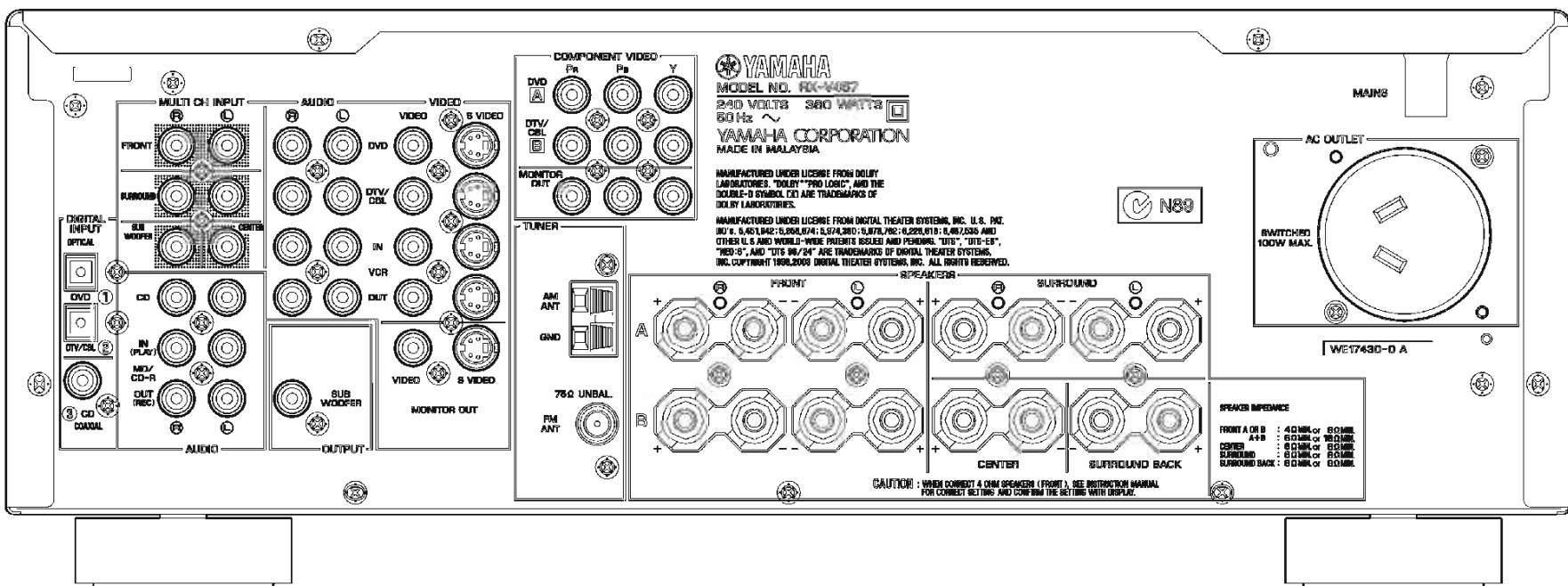

RX-V457 (B model)

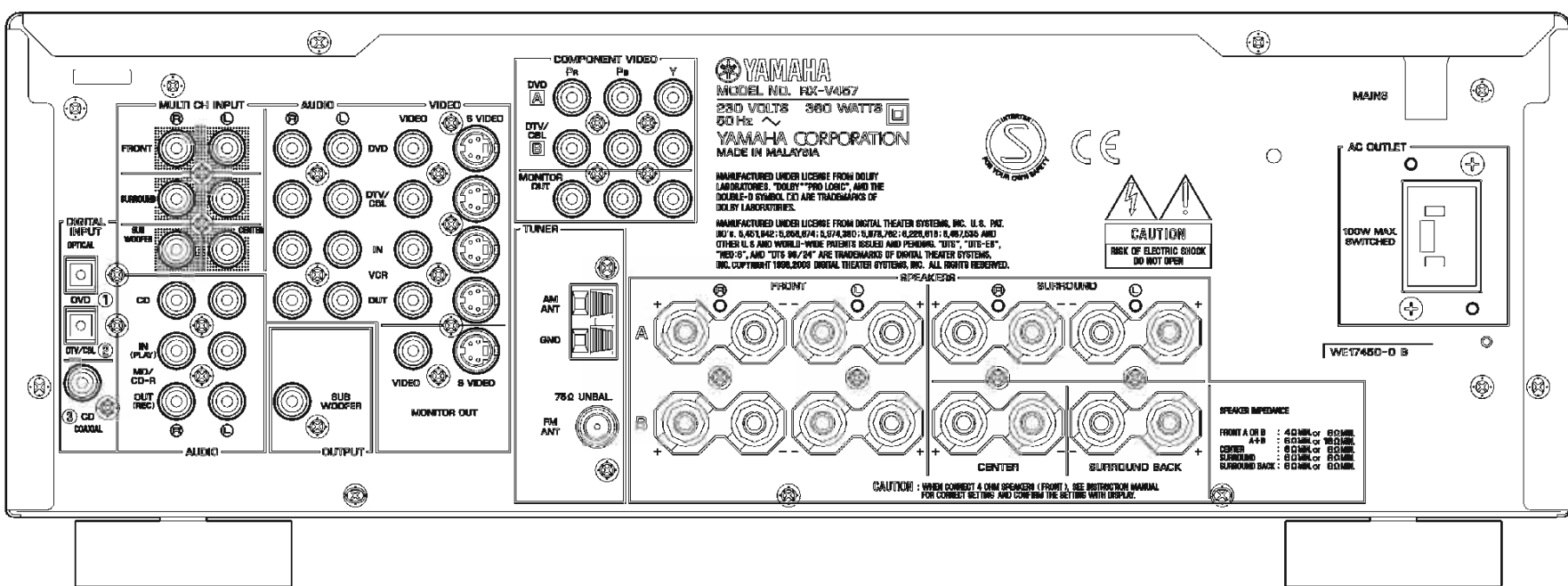

RX-V457 (G, E models)

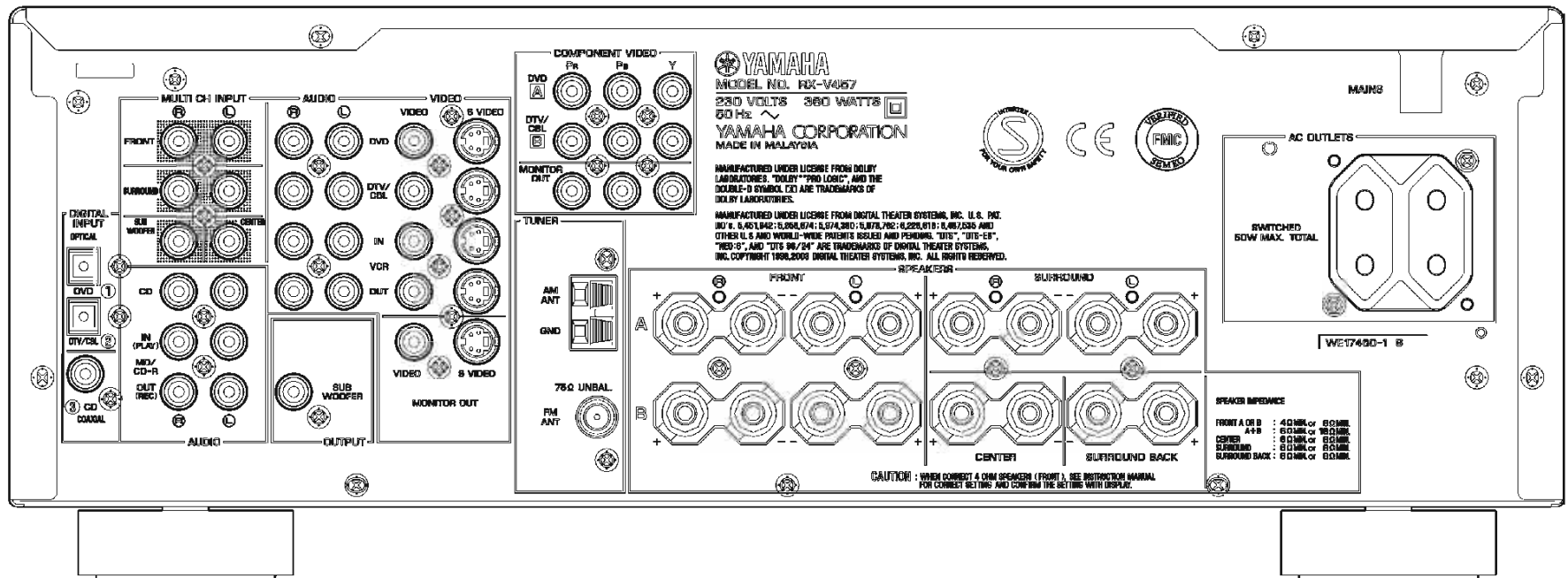

RX-V457 (L model)

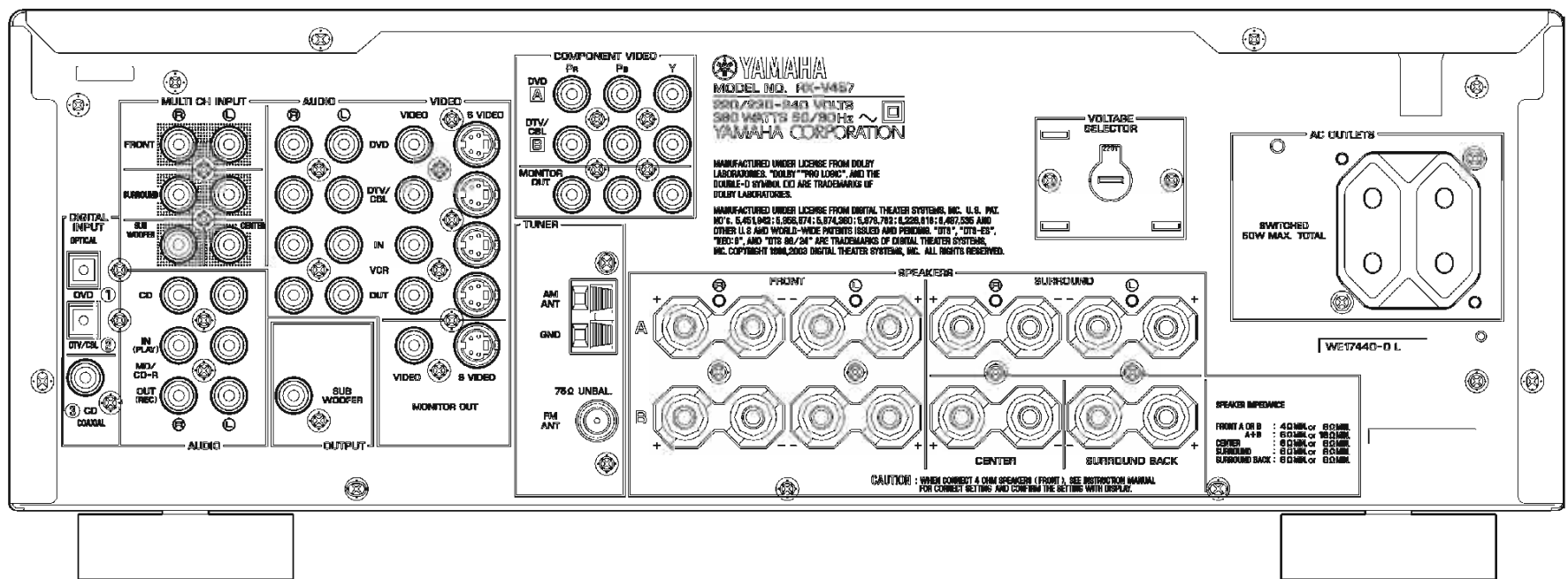

HTR-5840 (U, C models)

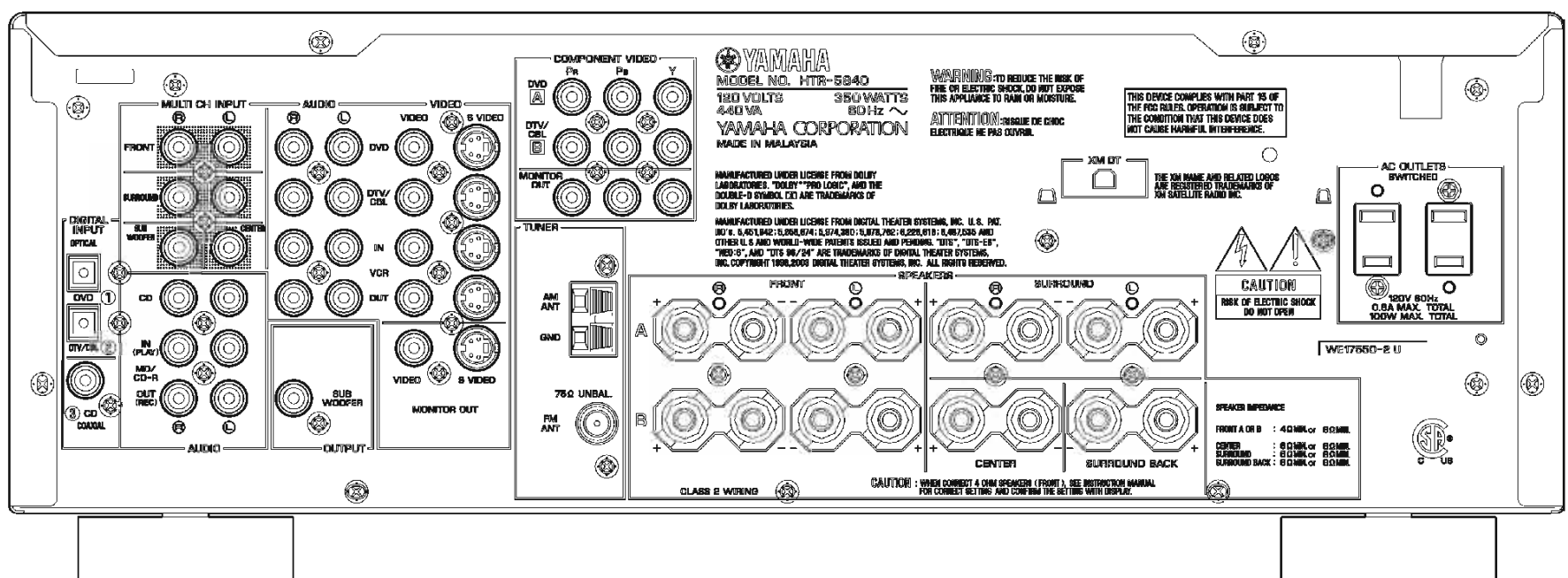

RX-V557/HTR-5850/DSP-AX557
RX-V457/HTR-5840/DSP-AX457

HTR-5840 (T model)

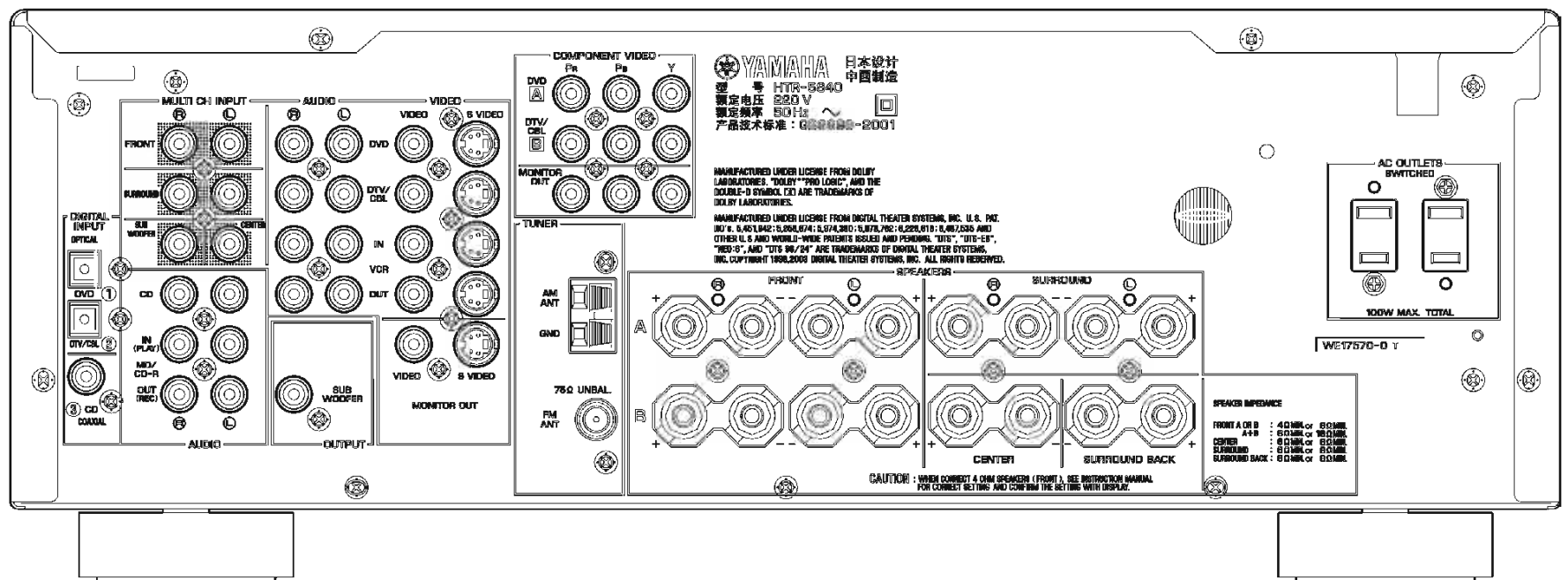

HTR-5840 (K model)

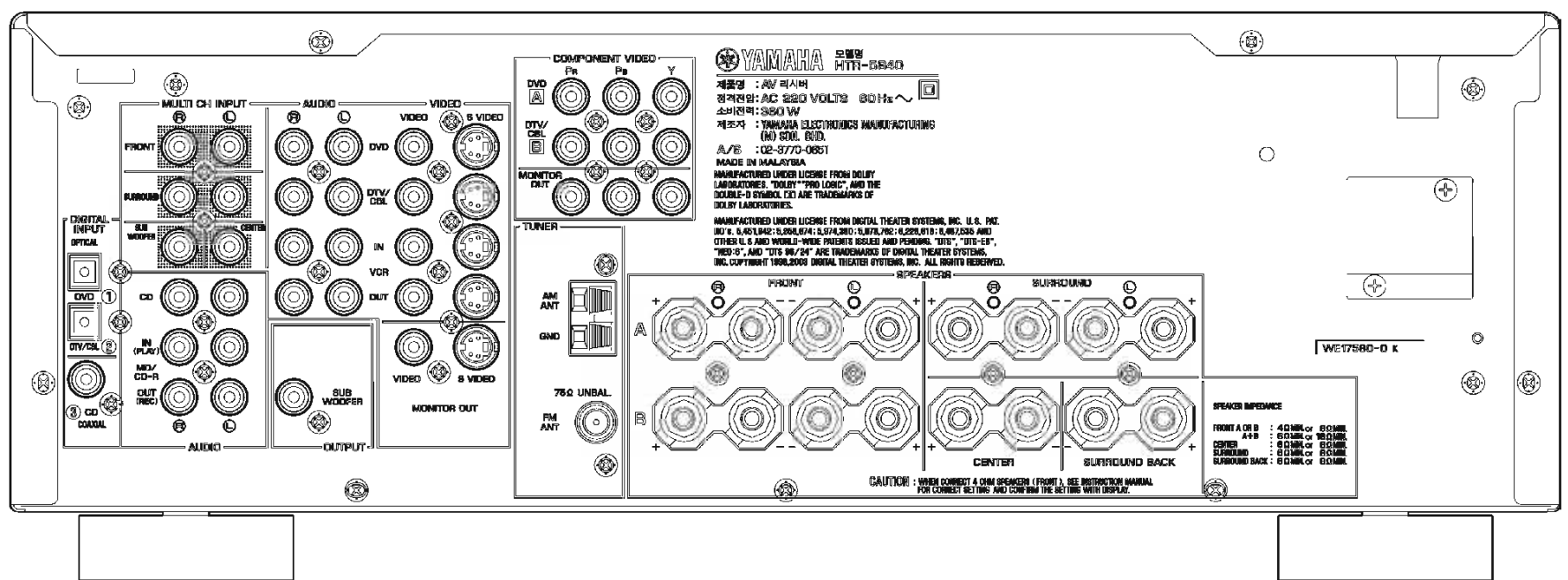

HTR-5840 (A model)

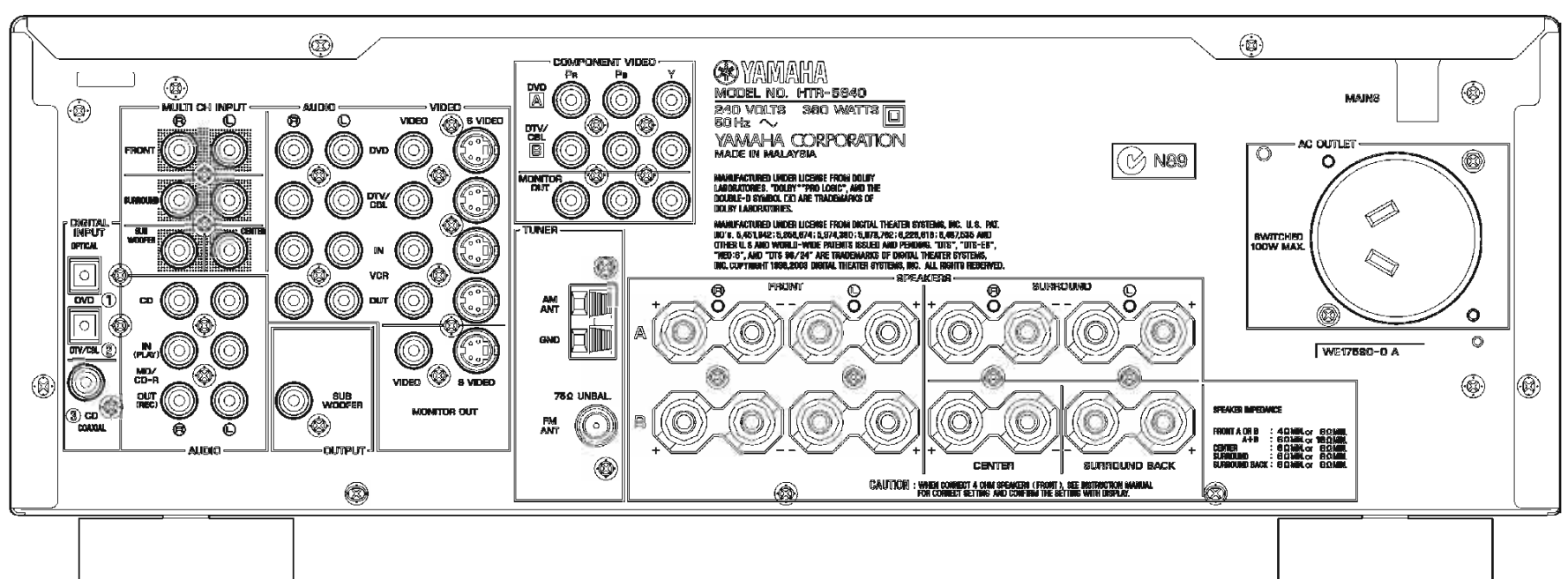

HTR-5840 (B model)

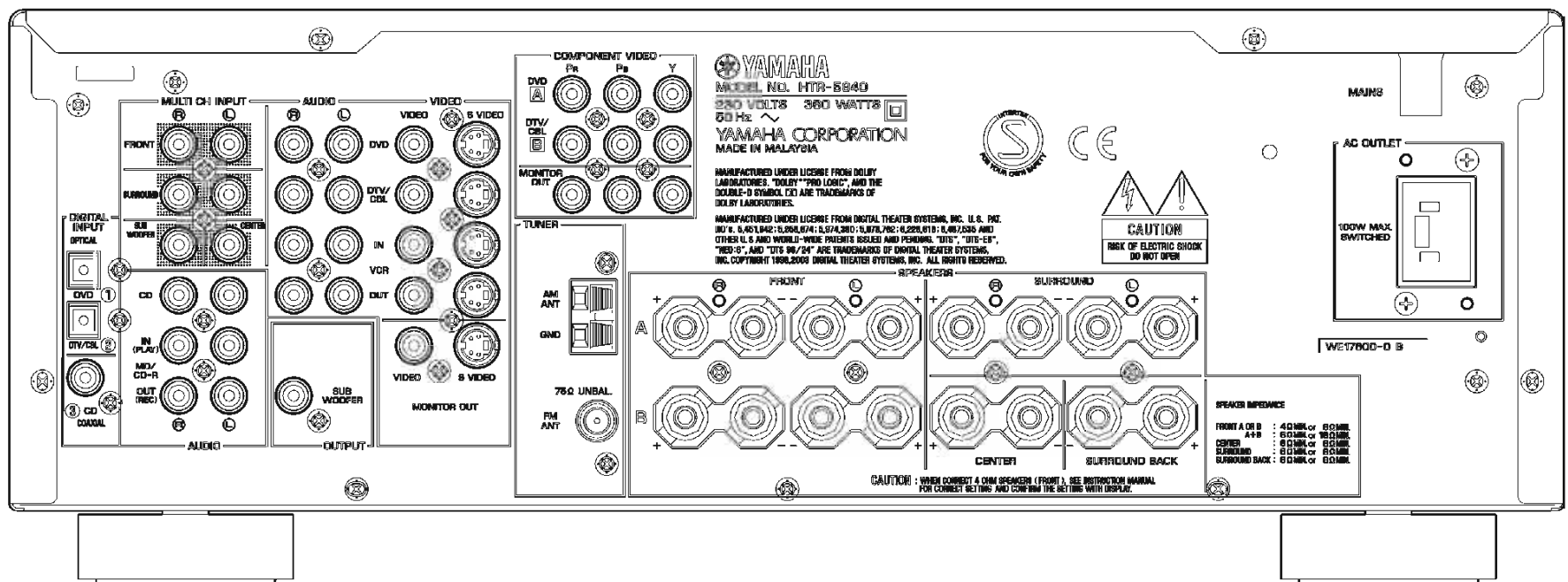

HTR-5840 (G, E models)

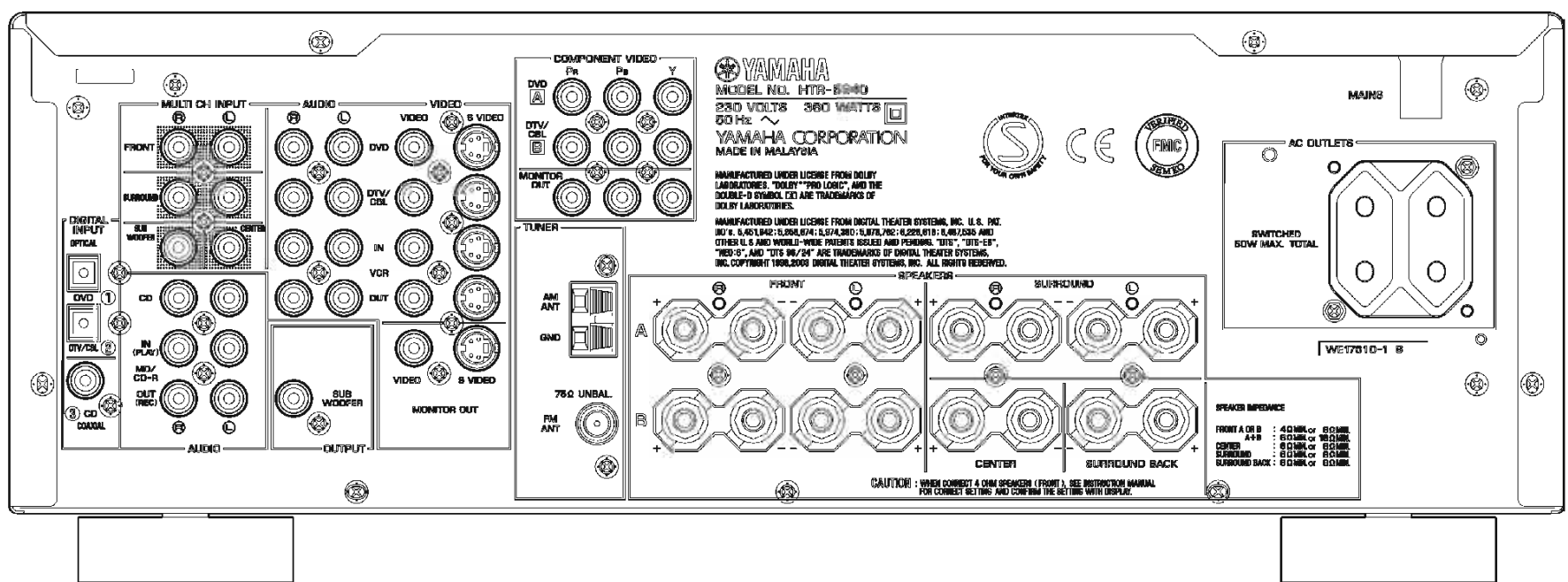

DSP-AX457 (J model)

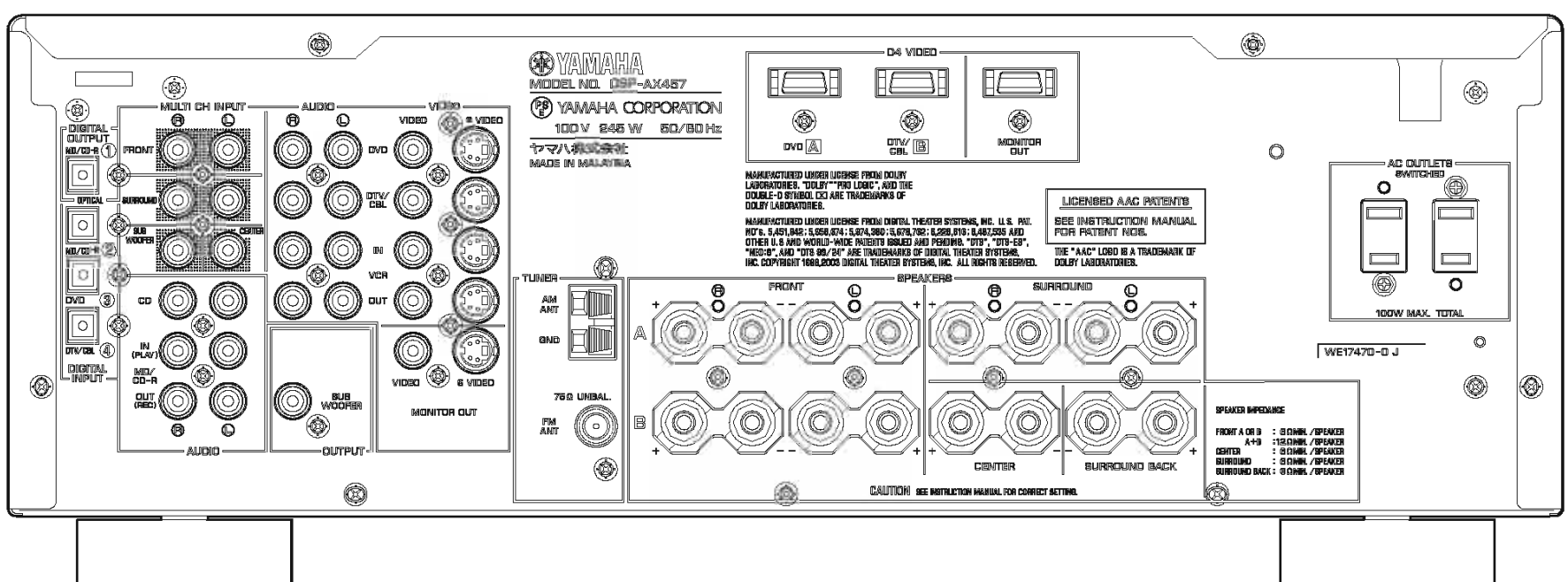

■ SPECIFICATIONS / 参考仕様

■ Audio Section / オーディオ部

Minimum RMS Output Power (Power Amp. Section) / 定格出力 (パワーアンプ部)

[RX-V557]
(20 Hz to 20 kHz, 0.09% THD, 8 ohms)

FRONT L/R	90 W + 90 W
CENTER	90 W
SURROUND L/R	90 W + 90 W
SURROUND BACK	90 W

[HTR-5850]
(1 kHz, 0.7% THD, 8 ohms)

FRONT L/R	105 W + 105 W
CENTER	105 W
SURROUND L/R	105 W + 105 W
SURROUND BACK	105 W

[DSP-AX557] (J model)
(20 Hz to 20 kHz, 0.09% THD, 6 ohms)

FRONT L/R	90 W + 90 W
CENTER	90 W
SURROUND L/R	90 W + 90 W
SURROUND BACK	90 W

[RX-V457]
(20 Hz to 20 kHz, 0.09% THD, 8 ohms)

FRONT L/R	85 W + 85 W
CENTER	85 W
SURROUND L/R	85 W + 85 W
SURROUND BACK	85 W

[HTR-5840]
(1 kHz, 0.7% THD, 8 ohms)

FRONT L/R	100 W + 100 W
CENTER	100 W
SURROUND L/R	100 W + 100 W
SURROUND BACK	100 W

[DSP-AX457] (J model)
(20 Hz to 20 kHz, 0.09% THD, 6 ohms)

FRONT L/R	85 W + 85 W
CENTER, REAR CENTER	85 W
SURROUND L/R	85 W + 85 W
SURROUND BACK	85 W

Maximum Power / 実用最大出力 (EIAJ) (1 kHz, 10% THD)

[RX-V557/HTR-5850] (R, T, K, L models)

FRONT L/R (8 ohms)	130 W + 130 W
CENTER, REAR CENTER (8 ohms)	130 W
SURROUND L/R (8 ohms)	130 W + 130 W
SURROUND BACK (8 ohms)	130 W

[DSP-AX557] (J model)

FRONT L/R (6 ohms)	130 W + 130 W
CENTER, REAR CENTER (6 ohms)	130 W
SURROUND L/R (6 ohms)	130 W + 130 W
SURROUND BACK (6 ohms)	130 W

[RX-V457/HTR-5840] (R, T, K, L models)

FRONT L/R (8 ohms)	125 W + 125 W
CENTER, REAR CENTER (8 ohms)	125 W
SURROUND L/R (8 ohms)	125 W + 125 W
SURROUND BACK (8 ohms)	125 W

[DSP-AX457] (J model)

FRONT L/R (6 ohms)	125 W + 125 W
CENTER, REAR CENTER (6 ohms)	125 W
SURROUND L/R (6 ohms)	125 W + 125 W
SURROUND BACK (6 ohms)	125 W

DIN Standard Output Power Per Channel / DINパワー (1 kHz, 0.7% THD, 4 ohms)

[RX-V557/HTR-5850] (B, G, E models)

FRONT L/R	135 W + 135 W
CENTER	135 W
SURROUND L/R	135 W + 135 W
SURROUND BACK	135 W

[RX-V457/HTR-5840] (B, G, E models)

FRONT L/R	130 W + 130 W
CENTER	130 W
SURROUND L/R	130 W + 130 W
SURROUND BACK	130 W

IEC Power / IECパワー (1 kHz, 0.06% THD, 8 ohms)

[RX-V557/HTR-5850] (B, G, E, L models)

FRONT L/R	100 W + 100 W
-----------	---------------

[RX-V457/HTR-5840] (B, G, E, L models)

FRONT L/R	95 W + 95 W
-----------	-------------

Dynamic Power Per Channel / ダイナミックパワー (IHF) (8/6/4/2 ohms)

[RX-V557/HTR-5850]

FRONT L/R	120/155/190/235 W
-----------	-------------------

[DSP-AX557] (J model)

FRONT L/R	~130/160/205 W
-----------	----------------

[RX-V457/HTR-5840]

FRONT L/R	115/150/185/230 W
-----------	-------------------

[DSP-AX457] (J model)

FRONT L/R	~125/155/200 W
-----------	----------------

Dynamic Headroom / ダイナミックヘッドルーム (8 ohms)

[RX-V557/HTR-5850] (U, C models) 1.25 dB

[RX-V457/HTR-5840] (U, C models) 1.31 dB

Damping Factor / ダンピングファクタ

20 Hz to 20 kHz, SPEAKER-A 120 or more

Input Sensitivity / Input Impedance (入力感度/入力インピーダンス)

CD, etc. 200 mV / 47 k-ohms

MULTI CH IN

FRONT L/R, CENTER, SURROUND L/R, SUB WOOFER

..... 200 mV / 47 k-ohms

Maximum Input Signal Level / 最大許容入力 (1 kHz, 0.5% THD)

CD, etc. (Effect On) 2.2 V or more

Output Level / Output Impedance (出力電圧/出力インピーダンス)

REC OUT 200 mV / 1.2 k-ohms

20 Hz SUB WOOFER 4 V / 1.2 k-ohms

[RX-V557] (U, C, A, B, G, E models)

ZONE2 OUT 200 mV / 1.2 k-ohms

Headphone Jack Rated Output / Impedance (ヘッドフォン出力/出力インピーダンス)

CD, etc. (1 kHz, 50 mV, 8 ohms) 150 mV / 100 ohms

Frequency Response / 周波数特性

CD, etc. to FRONT L/R (10 Hz to 100 kHz) +0/-3.0 dB

Total Harmonic Distortion / 全高調波歪率

(20 Hz to 20 kHz, 40 W, 8 ohms)

CD, etc. (Effect Off) to FRONT L/R SP OUT 0.06 % or less

Signal to Noise Ratio / 信号対雑音比 (IHF-A Network)

CD, etc. (Input shorted) SP OUT

250 mV 100 dB or more

Residual Noise / 残留ノイズ (IHF-A Network)

FRONT L/R SP OUT 150 μV or less

Channel Separation / チャンネルセパレーション

CD, etc. (Input 5.1 k-ohms shorted, 1 kHz/10 kHz)

60 dB or more/45 dB or more

Tone Control Characteristics / トーンコントロール特性

BASS

Boost/Cut ±10 dB (60 Hz)

TREBLE

Boost/Cut ±10 dB (20 kHz)

Filter Characteristics / フィルター特性

FRONT L/R, CENTER, SURROUND L/R, SURROUND BACK SP

Small (H.P.F.)

fc= 40/60/80/90/100/110/120/160/200 Hz / 12 dB/ oct.

SUBWOOFER (L.P.F.)

fc= 40/60/80/90/100/110/120/160/200 Hz / 24 dB/ oct.

■ Video Section / ビデオ部

Video Signal Type / ビデオ信号方式

U, C, R, K, J models NTSC

T, A, B, G, E, L models PAL

Video Signal Type (Video Conversion) / ビデオ信号方式 (ビデオコンバージョン)

[RX-V557/HTR-5850/DSP-AX557]

U, C, R, K, A, B, G, E, L, J models NTSC

R, T, A, B, G, E, L models PAL

Composite Video Signal Level / コンポジットビデオ信号

1 Vp-p / 75 ohms

S-Video Signal Level / Sビデオ信号

Y 1 Vp-p / 75 ohms

C 0.286 Vp-p / 75 ohms

Component Signal Level (U, C, R, T, K, A, B, G, E, L models)

Y 1 Vp-p / 75 ohms

Cb/Cr 0.7 Vp-p / 75 ohms

• DIMENSIONS / 寸法図

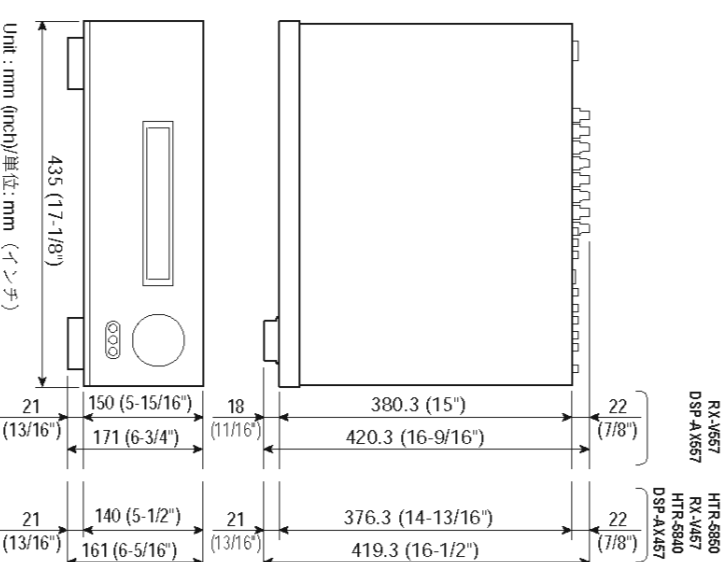

• The variable range of the parameter (Min/Max/Step) / パラメーターの可変範囲 (最小/最大/ステップ)

PARAMETER NAME	PROGRAM NAME										UNIT
	MUSIC		ENTERTAINMENT		TV THEATER		MOVIE THEATER		PRO LOGIC		
DSP LEVEL	-6/3/1	-6/3/1	-6/3/1	-6/3/1	-6/3/1	-6/3/1	-6/3/1	-6/3/1	-6/3/1	-6/3/1	dB
INT. DELY	1/99/1	1/99/1	1/99/1	1/99/1	1/99/1	1/99/1	1/99/1	1/99/1	1/99/1	1/99/1	ms
ROOM SIZE	0.1/2.0/0.1	0.1/2.0/0.1	0.1/2.0/0.1	0.1/2.0/0.1	0.1/2.0/0.1	0.1/2.0/0.1	0.1/2.0/0.1	0.1/2.0/0.1	0.1/2.0/0.1	0.1/2.0/0.1	ms
LIVENESS	0/1/0/1	0/1/0/1	0/1/0/1	0/1/0/1	0/1/0/1	0/1/0/1	0/1/0/1	0/1/0/1	0/1/0/1	0/1/0/1	ms
P. INT. DELY											
P. ROOM SIZE											
S. LIVENESS											ms
S. INT. DELY											
S. ROOM SIZE											
S. LIVENESS											ms
SB. INIT. DELY											
SB. RM SIZE											
REV. LEVEL											ms
REV. DELY											ms
PLI/PLIUX											%
PANORAMA											
DIMENSIONS											
CT WIDTH											
C. IMAGE											

7CH STEREO PARAMETER	
CF LEVEL	0/1/0/1 %
SL LEVEL	0/1/0/1 %
SR LEVEL	0/1/0/1 %
SB1 LEVEL	0/1/0/1 %
SB2 LEVEL	0/1/0/1 %

Weight / 質量 11.0 kg (24 lbs. 4 oz.)

Finish / 仕上げ

[RX-V557]

Gold color R, T, K models

Black color U, C, R, A, B, G, E models

Titanium color C, A, B, G, E, L models

[HTR-5850]

Gold color T model

Black color U, C models

Silver color J, C, K, A models

[DSP-AX557]

Gold color J model

[RX-V457]

Gold color R, T, K, L models

Black color U, C, R, A, B, G, E models

Silver color R, K, L models

Titanium color C, A, B, G, E models

[HTR-5840]

Gold color T model

Black color U, C, G, E models

Silver color U, C, K, A, B, G, E models

[DSP-AX457]

Gold color J model

Silver color J model

Accessories / 付属品

Remote Control x 1, Batteries (Manganese Dry) x 4 (RAV254/RAV255), Batteries x 2 (RAV304), Indoor FM Antenna x 1, AM Loop Antenna x 1, Antenna Adapter x 1 [PAL / 59300 ohms] (B model)

* Specifications are subject to change without notice due to product improvements.

※ 参考仕様および外観は予告なく変更されることがあります。

- U U.S.A. model
- R General model
- T Chinese model
- K Korean model
- A Australian model
- B British model
- G European model
- S South European model
- L Singapore model
- J Japanese model



Manufactured under license from Dolby Laboratories. "Dolby", "Pro Logic", "Surround EX", and the double-D symbol are trademarks of Dolby Laboratories.

ドルビーラボラトリーズからの実権により製造されています。「ドルビー」、「PRO LOGIC」、「Surround EX」およびダブルD記号DDは、ドルビーラボラトリーズの商標です。

SILENT™ CINEMA

"SILENT CINEMA" is a trademark of YAMAHA CORPORATION. 「サイレントシネマ」/SILENT CINEMA はヤマハ株式会社の登録商標です。



"DTS", "DTS-ES", "Neo:6" and "DTS 96/24" are trademarks of Digital Theater Systems, Inc.

DTS、DTS-ES Extended Surround、Neo:6およびDTS 96/24はデジタルシアターシステムの登録商標です。



The XM name and related logos are registered trademarks of XM Satellite Radio Inc.



AACロケーターはドルビーラボラトリーズの商標です。

D4-Video Signal Level / D4端子ビデオ信号 (J model)

Y 1 Vp-p / 75 ohms

Cb/Cr 0.7 Vp-p / 75 ohms

Maximum Input Level / 最大許容入力 1.5 Vp-p or more

Signal to Noise Ratio / 信号対雑音比 50 dB or more

Monitor Out Frequency Response / モニターアウト周波数帯域

Composite Video Signal Level:

S-Video Signal Level 5 Hz to 10 MHz, -3 dB

D4-Video Signal Level (J model) 5 Hz to 60 MHz, -3 dB

[RX-V557/HTR-5850/DSP-AX557]

Component Video Signal Level 5 Hz to 60 MHz, -3 dB

[RX-V457/HTR-5840/DSP-AX457]

Component Video Signal Level (U, C, R, T, K, A, B, G, E, L models) 5 Hz to 60 MHz, -3 dB

■ FM Section / FM部

Tuning Range / 受信周波数範囲

U, C models 87.5 to 107.9 MHz

R, L models 87.5 to 108.0 / 87.50 to 108.00 MHz

T, K, A, B, G, E models 87.50 to 108.00 MHz

J model 76.0 to 90.0 MHz

50 dB Quieting Sensitivity / 50 dB SN感度 (HF) (1 kHz, 100% Mod.)

Mono / Stereo 2.0 μV (17.3 dBf) / 25 μV (39.2 dBf)

Usable Sensitivity / 実用感度 (HF)

Mono 1.0 μV (11.2 dBf)

Selectivity / 選振度 (400 kHz) 70 dB

Sensitivity to Noise Ratio / 信号対雑音比 (HF)

Mono / Stereo 76 dB / 70 dB

Harmonic Distortion / 歪率 (1 kHz)

Mono/Stereo 0.2 / 0.3 %

Stereo Separation / ステレオセパレーション

1 kHz 42 dB

Frequency Response / 周波数特性

20 Hz to 15 kHz +0.5 / -2 dB

Antenna Input / アンテナ入力 75 ohms unbalanced

■ AM Section / AM部

Tuning Range / 受信周波数範囲

U, C models 530 to 1,710 kHz

R, L models 530 to 1,710 / 531 to 1,611 kHz

T, K, A, B, G, E, J models 531 to 1,611 kHz

Usable Sensitivity / 実用感度 300 μV/m

Antenna / アンテナ入力 Loop Antenna

■ General / 総合

Power Supply / 電源電圧

U, C models AC 120 V, 60 Hz

R model AC 110/120/230/240 V, 50/60 Hz

T model AC 220 V, 50 Hz

K model AC 220 V, 60 Hz

A model AC 240 V, 50 Hz

B, G, E models AC 230 V, 50 Hz

L model AC 220/230-240 V, 50/60 Hz

J model AC 100V, 50/60 Hz

Power Consumption / 消費電力

U, C models 350 W / 440 VA

R, T, K, A, B, G, E, L models 360 W

J model 245 W

Standby Power Consumption (reference data) / 待機時消費電力 (参考値)

AC240 V / 50 Hz 0.1 W

Maximum Power Consumption (R model)

6ch Drive, 10% THD 700 W

AC Outlets / AC7アウトレット

2 Switched Outlets

U, C, T, J models 100 W max. total

R, G, E, L models 50 W max. total

1 Switched Outlet

A, B models 100 W max.

Dimensions / 寸法 (W x H x D)

[RX-V557/DSP-AX557]

435 x 171 x 420.3 mm (17-1/8" x 6-3/4" x 16-9/16")

[HTR-5850/RX-V457/HTR-5840/DSP-AX457]

435 x 161 x 419.3 mm (17-1/8" x 6-5/16" x 16-1/2")

• Set Menu Table / セットメニュー

CATEGORY	MAIN MENU	SUB MENU	SELECT MENU	VALUE [INITIAL]	
• BASIC SETUP		ROOM : S > M L	S / [M] / L		
		SUBWOOFER : YES	[YES] / NONE		
		SPEAKERS : 6spk	2 / 3 / 4 / 5 / [6]		
		>SET CANCEL	[SET] / CANCEL		
		CHECK OK? : YES	[YES] / NO		
		FR..... 			
		C..... 			
		SL..... 	± 10.0 dB step		
		SB..... 			
		SWFR..... 			
• MANUAL SETUP	1 SOUND MENU	A) SPEAKER SET	FRONT : LARGE	SMALL / [LARGE]	
		CENTER : SML			
		SURLR : SML			
		SUR B : SML	NONE / [SML] / LRG		
		BASS OUT : BOTH	SWFR / FRONT / [BOTH]		
		Cross Over : 80 Hz	40 / 60 / [80] / 90 / 100 / 110 / 120 / 160 / 200 Hz		
		SWFR PHASE : NRM	[NRM] / REV		
		B) SP LEVEL	FL..... 		
		FR..... 			
		C..... 	-10.0 dB to +10.0 dB [0.0 dB] / 1.0 dB step		
SL..... 					
SR..... 					
SB..... 					
SWFR..... 					
C) SP DISTANCE		UNIT : feet	feet (U, C models) / meters (R, T, K, A, B, G, E, L, J models)		
		FRONT L 10.0 ft / 3.00 m			
		FRONT R 10.0 ft / 3.00 m			
		CENTER 10.0 ft / 3.00 m	feet : 1.0 ft to 80.0 ft [10.0 ft] / 0.5 ft step		
		SUR L 10.0 ft / 3.00 m			
		SUR R 10.0 ft / 3.00 m			
		SUR B 10.0 ft / 3.00 m	meters : 0.30 m to 24.00 m [3.00 m] / 0.10 m step		
		SWFR 10.0 ft / 3.00 m			
		D) CENTER GEO	TEST : >OFF ON	[OFF] / ON	
		100 Hz - - 0			
300 Hz - - 0					
1 kHz - - 0	-6 dB to +6 dB [0 dB] / 1 dB step				
3 kHz - - 0					
10 kHz - - 0					
E) LFE LEVEL	SP LFE : 0	-20 dB to 0 dB [0 dB] / 1 step			
HP LFE : 0					
F) D. RANGE	SP D. R. : MAX	MIN / STD / [MAX]			
HP D. R. : MAX					
G) AUDIO SET	MUTE TYP : MUTE	-20 dB / [MUTE]			
A. DELAY : 0 ms	0 ms to 160 ms / 1 step				
TC. BYPASS : AUTO	OFF / [AUTO]				
DUAL MONO : MAIN	[MAIN] / SUB / ALL (J model)				

CATEGORY	MAIN MENU	SUB MENU	SELECT MENU	VALUE [INITIAL]
3 OPTION MENU		A) I/O ASSIGN	C. V [A] : DVD	[DVD] / VCR / V-AUX / DTVCBL
		C. V [B] : DTVCBL	--- / VCR / V-AUX / [DTVCBL]	
		OUT (1) : MD/CD-R	[MD/CD-R] / CD / VCR / V-AUX / DTVCBL / DVD	
		IN (2) : MD/CD-R	(RX-V557, HTR-5850, DSP-AX557)	
		IN (3) : DVD	--- / CD / VCR / V-AUX / DTVCBL / [DVD]	
		IN (4) : DTVCBL	--- / CD / VCR / V-AUX / [DTVCBL] / DVD	
		IN (5) : CD	MD/CD-R / [CD] / VCR / V-AUX / DTVCBL / DVD	
		> AUTO / LAST	[AUTO] / LAST	
		B) INPUT MODE	CD	Input is possible to 8 characters / 最大8文字まで入力可能
		C) INPUT RENAME	MD/CD-R	Input is possible Character type / 入力可能文字
A) DISPLAY SET		TUNER	CAPITAL / 英大文字 A to Z	
		DVD	SMALL / 英小文字 a to z	
		DTVCBL	FIGURE / 数字 0 to 9	
		V-AUX	Space / 空白	
		VCR	MARK / 記号 # * - + / ; < > ? etc.	
		DIMMER : 0	-5 to 0 / 1 step	
		V CONV. : ON	OFF / [ON]	
		MEM. GUARD : OFF	[OFF] / ON	
		B) MEMORY GUARD		
		C) PARAM. INI		
D) MULTI ZONE	SP B : MAIN	[MAIN] / ZONE B		
E) XM RADIO (U model)	ANTENNA : NONE	[NONE] / 0 % to 100 %		

INTERNAL VIEW

RX-V557/DSP-AX577

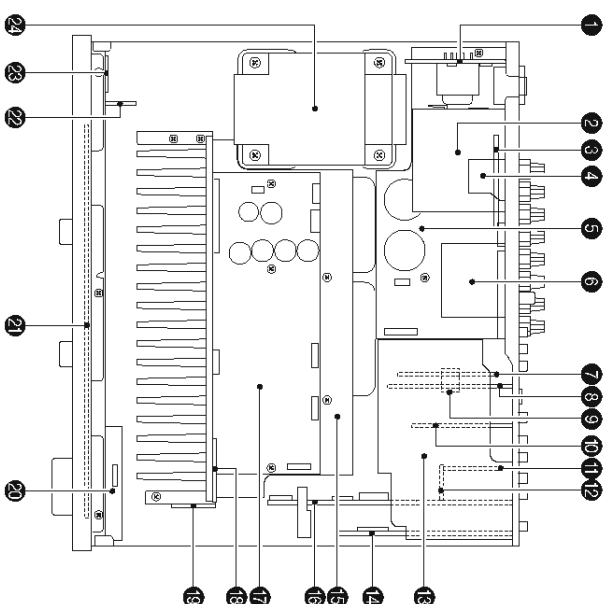

- 1 SUBTRANS(1) P.C.B.
- 2 XM P.C.B. (U, C models)
- 3 SUBTRANS(5) P.C.B. (R, L models)
- 4 SUBTRANS(8) P.C.B. (U, C, A, B, G, E models)
- 5 MAIN (2) P.C.B.
- 6 Tuner
- 7 CONVERSION P.C.B.
- 8 SUBTRANS(3) P.C.B.
- 9 SUBTRANS(10) P.C.B.
- 10 SUBTRANS(6) P.C.B.
- 11 SUBTRANS(7) P.C.B.
- 12 SUBTRANS(9) P.C.B.
- 13 SUBTRANS(2) P.C.B.
- 14 DSP P.C.B.
- 15 MAIN (1) P.C.B.
- 16 FUNCTION P.C.B.
- 17 POWER (1) P.C.B.
- 18 MAIN (5) P.C.B.
- 19 POWER (2) P.C.B.
- 20 OPERATION (5) P.C.B.
- 21 OPERATION (1) P.C.B.
- 22 OPERATION (3) P.C.B.
- 23 OPERATION (2) P.C.B.
- 24 Power Transformer

HTR-5850

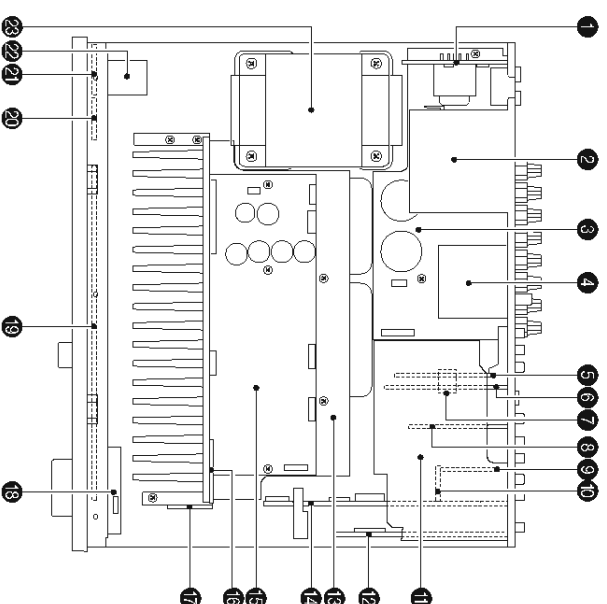

- 1 SUBTRANS(1) P.C.B.
- 2 XM P.C.B. (U, C models)
- 3 MAIN (2) P.C.B.
- 4 Tuner
- 5 CONVERSION P.C.B
- 6 SUBTRANS(3) P.C.B.
- 7 SUBTRANS(10) P.C.B.
- 8 SUBTRANS(6) P.C.B.
- 9 SUBTRANS(7) P.C.B.
- 10 SUBTRANS(9) P.C.B.
- 11 SUBTRANS(2) P.C.B.
- 12 DSP P.C.B.
- 13 MAIN (1) P.C.B.
- 14 FUNCTION P.C.B.
- 15 POWER (1) P.C.B.
- 16 MAIN (5) P.C.B.
- 17 POWER (2) P.C.B.
- 18 OPERATION (4) P.C.B.
- 19 OPERATION (1) P.C.B.
- 20 OPERATION (5) P.C.B.
- 21 OPERATION (2) P.C.B.
- 22 OPERATION (3) P.C.B.
- 23 Power Transformer

RX-V457/HTR-5840/DSP-AX457

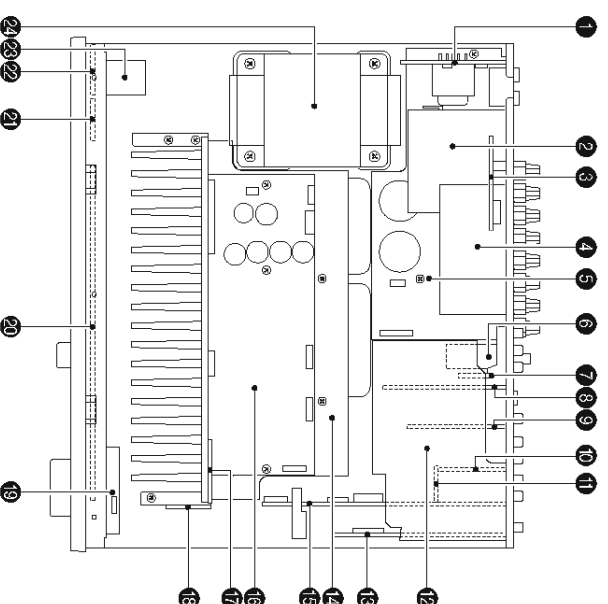

- 1 SUBTRANS(1) P.C.B.
- 2 XM P.C.B. (U, C models)
- 3 SUBTRANS(5) P.C.B. (R, L models)
- 4 VIDEO P.C.B. (J model)
- 5 MAIN (2) P.C.B.
- 6 Tuner
- 7 SUBTRANS(4) P.C.B. (U, C, R, T, K, A, B, G, E, L models)
- 8 SUBTRANS(3) P.C.B.
- 9 SUBTRANS(6) P.C.B.
- 10 SUBTRANS(7) P.C.B.
- 11 SUBTRANS(9) P.C.B.
- 12 SUBTRANS(2) P.C.B.
- 13 DSP P.C.B.
- 14 MAIN (1) P.C.B.
- 15 FUNCTION P.C.B.
- 16 POWER (1) P.C.B.
- 17 MAIN (5) P.C.B.
- 18 POWER (2) P.C.B.
- 19 OPERATION (4) P.C.B.
- 20 OPERATION (1) P.C.B.
- 21 OPERATION (5) P.C.B.
- 22 OPERATION (2) P.C.B.
- 23 OPERATION (3) P.C.B.
- 24 Power Transformer

REMOTE CONTROL PANELS

- RX-V557 (U, C, R, T, K, A, L models)
- HTR-5850 (U, C, T, K, A models)
- DSP-AX557 (J model)
- RX-V457 (U, C, R, T, K, A, L models)
- HTR-5840 (U, C, T, K, A models)
- DSP-AX457 (J model)

RX-V557 (B, G, E models)

RX-V457 (B, G, E models)

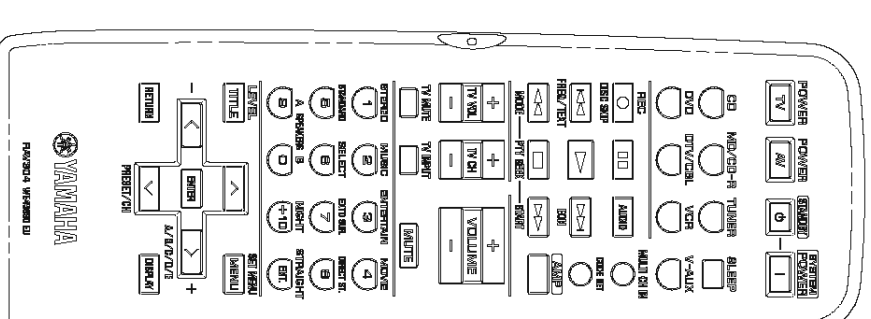
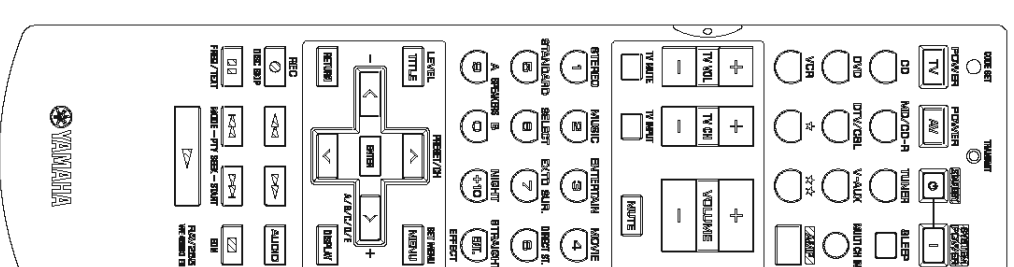
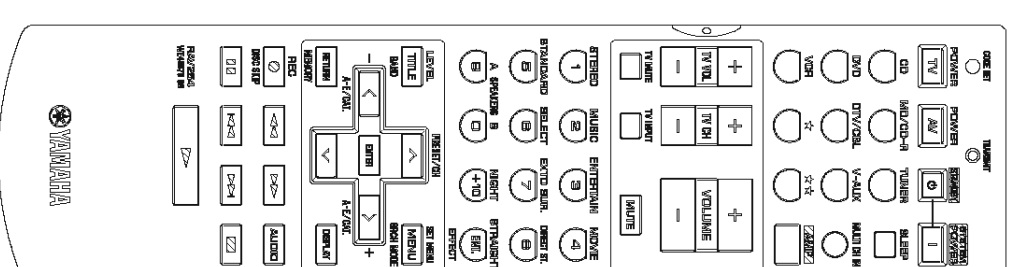

DISASSEMBLY PROCEDURES

(Remove parts in the order as numbered.)
Disconnect the power cable from the AC outlet.

1. Removal of Top Cover

- Remove 4 screws (①) and 5 screws (②). (Fig. 1)
- Slide the Top Cover rearward to remove it. (Fig. 1)

2. Removal of Front Panel Unit

- Remove 2 Knobs. (Fig. 1)
- Remove 1 screw (③) and then remove the Support Top. (Fig. 1)
- Remove 6 screws (④) and then remove the Front Panel Unit. (Fig. 1)

3. Removal of Plate Side

- Remove 2 push rivets (⑤). (Fig. 1)
- Remove the Plate Side U/R. (Fig. 1)

4. Removal of Sub Chassis Unit

- Remove 2 screws (⑥) and then slide the Sub Chassis Unit forward. (Fig. 1)
- Loosen the harness fixture fixing the cable.
- Remove CB306, CB309, CB456 and CB863 and then remove the Sub Chassis Unit. (Fig. 1)

(番号順に部品を取外してください。)
AC電源コンセントから、電源コードを抜いてください。

1. トップカバーの取外し方

- ①のネジ4本、②のネジ5本を外します。(Fig. 1)
- トップカバーを後方へスライドさせ、取外します。(Fig. 1)

2. フロントパネルユニットの取外し方

- ノブを2個取外します。(Fig. 1)
- ③のネジ1本を外し、サポートトップを取外します。(Fig. 1)
- ④のネジ6本を外し、フロントパネルユニットを取外します。(Fig. 1)

3. プレートサイドの取外し方

- ⑤のワッシャー/ハット本を外します。(Fig. 1)
- プレートサイドU/Rを取外します。(Fig. 1)

4. サブシャーシユニットの取外し方

- ⑥のネジ2本を外し、サブシャーシユニットを前方に引き出します。(Fig. 1)
- ケーブルを固定している束線止めをゆるめます。
- CB306、CB309、CB456、CB863を外し、サブシャーシユニットを取外します。(Fig. 1)

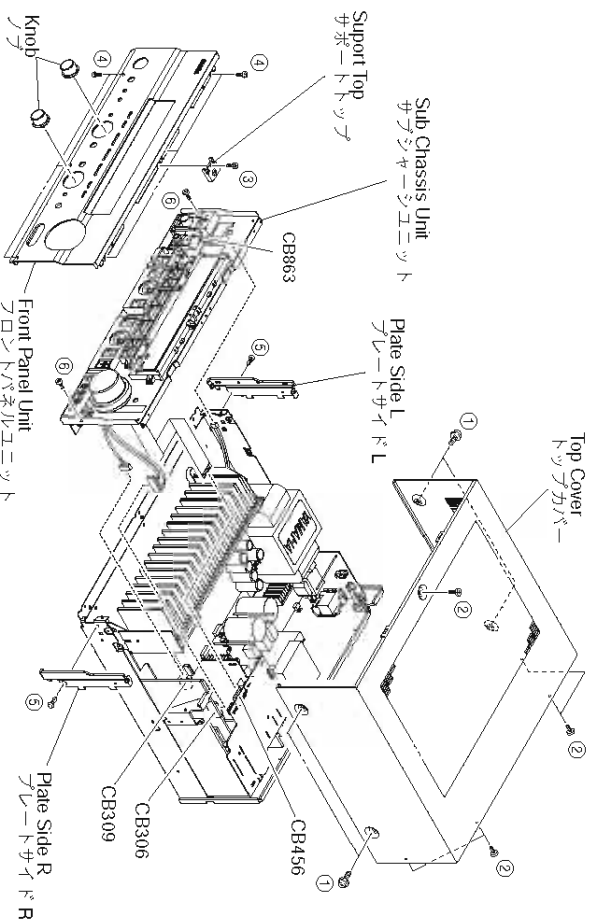

Fig. 1

5. Removal of DSP P.C.B.

- Remove 1 screw (⑦). (Fig. 2)
- Remove 7 screws (⑧). (Fig. 3)
- Remove CB2 and CB11. (Fig. 2)
- Lift up the SUBTRANS (2) P.C.B. and remove the CB1. (Fig. 2)
- Remove the DSP P.C.B. with the Support/DSP. (Fig. 2)

1. トーナメントの取外し方

- ①のネジ4本、②のネジ5本を外します。(Fig. 1)
- トップカバーを後方へスライドさせ、取外します。(Fig. 1)

2. フロントパネルユニットの取外し方

- ノブを2個取外します。(Fig. 1)
- ③のネジ1本を外し、サポートトップを取外します。(Fig. 1)
- ④のネジ6本を外し、フロントパネルユニットを取外します。(Fig. 1)

3. プレートサイドの取外し方

- ⑤のワッシャー/ハット本を外します。(Fig. 1)
- プレートサイドU/Rを取外します。(Fig. 1)

4. サブシャーシユニットの取外し方

- ⑥のネジ2本を外し、サブシャーシユニットを前方に引き出します。(Fig. 1)
- ケーブルを固定している束線止めをゆるめます。
- CB306、CB309、CB456、CB863を外し、サブシャーシユニットを取外します。(Fig. 1)

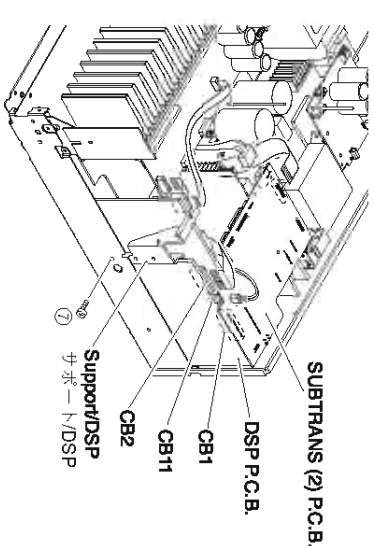

Fig. 2

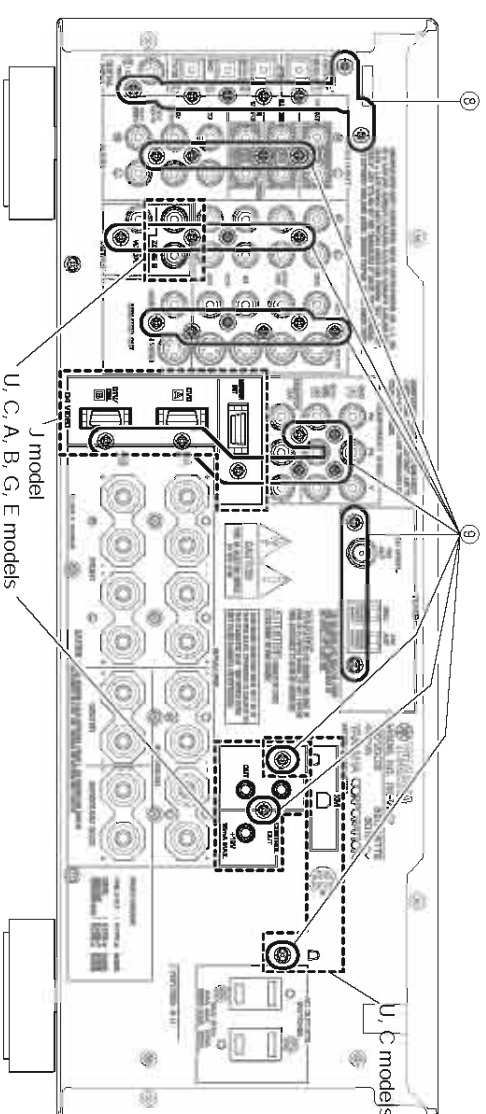

Fig. 3

6. Removal of FUNCTION, SUBTRANS (2), (3), (6), (7), (8) (U, C, A, B, G, E models), (9), (10), CONVERSION, XM (U, C models) P.C.B.s and Tuner

- Remove CB21, CB23, CB24 (U, C models), CB307, CB351, CB452, CB453 and CB706. (Fig. 4)
- Remove 23 (U, C models) / 21 (A, B, G, E models) / 19 (R, T, K, L models) screws (⑨). (Fig. 3)
- Remove FUNCTION, SUBTRANS (2), (3), (6), (7), (8) (U, C, A, B, G, E models), (9), (10), CONVERSION, XM (U, C models) P.C.B.s and the Tuner. (Fig. 4)

6. FUNCTION, SUBTRANS (2), (3), (6), (7), (9), (10), CONVERSION P.C.B., TUNERの取外し方

- CB307、CB351、CB452、CB453、CB706を外します。(Fig. 4)
- ⑨のネジ22本を取外します。(Fig. 3)
- FUNCTION, SUBTRANS (2), (3), (6)~(10)、CONVERSION P.C.B.、TUNERを取外します。(Fig. 4)

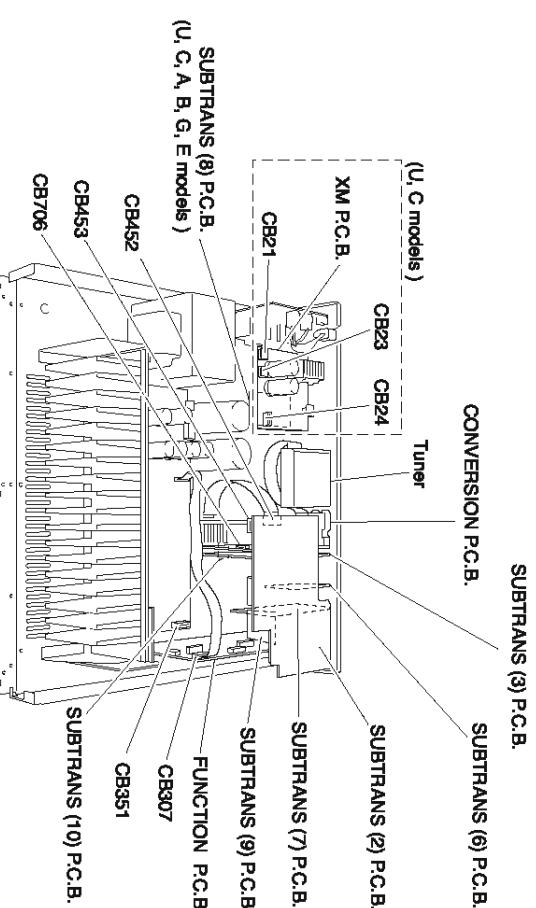

Fig. 4

5. DSP P.C.B.の取外し方

- ⑦のネジ1本を外します。(Fig. 2)
- ⑧のネジ7本を外します。(Fig. 3)
- CB2、CB11を外します。(Fig. 2)
- SUBTRANS (2) P.C.B.を上向きに浮かせCB1を外します。(Fig. 2)
- DSP P.C.B.をサポート/DSPと共に取外します。(Fig. 2)

DISASSEMBLY PROCEDURES / 分解手順

(Remove parts in the order as numbered.)

Disconnected the power cable from the AC outlet.

(番号順に部品を取外してください。)
AC電源コンセントから、電源コードを抜いてください。

1. Removal of Top Cover

- Remove 4 screws (①) and 5 screws (②). (Fig. 1)
- Slide the Top Cover rearward to remove it. (Fig. 1)

1. トップカバーの外し方

- ①のネジ4本、②のネジ5本を外します。(Fig. 1)
- トップカバーを後方へスライドさせ、取外します。(Fig. 1)

2. Removal of Front Panel Unit

- Remove 7 screws (③) and then slide the Front Panel Unit forward. (Fig. 1)
- Loosen the harness fixture fixing the cable.
- Remove CB306, CB309, CB456 and CB863 and then remove the Front Panel Unit. (Fig. 1)

2. フロントパネルユニットの外し方

- ③のネジ7本を外し、フロントパネルユニットを前方へ引き出します。(Fig. 1)
- ケーブルを固定している束縛止めをゆるめます。
- CB306、CB309、CB456、CB863を外し、フロントパネルユニットを取外します。(Fig. 1)

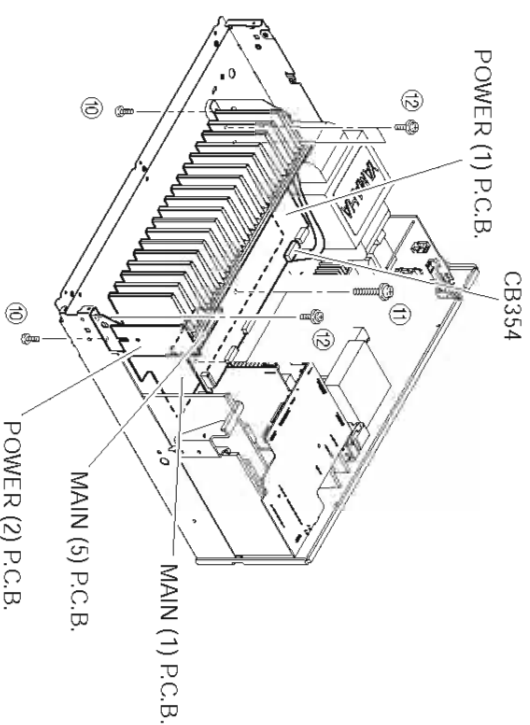

Fig. 5

- Removal of MAIN (1), (5) and POWER (1), (2) P.C.B.s
 - Remove CB354. (Fig. 5)
 - Remove 2 screws (⑩), 2 screws (⑪) and 3 screws (⑫). (Fig. 5)
 - Remove MAIN (1), (5) and POWER (1), (2) P.C.B.s. (Fig. 5)

- MAIN (1), (5), POWER (1), (2) P.C.B.の外し方
 - CB354を外します。(Fig. 5)
 - ⑩のネジ2本、⑪のネジ2本、⑫のネジ3本を外します。(Fig. 5)
 - MAIN (1), (5)、POWER (1), (2) P.C.B.を取外します。(Fig. 5)

When checking the P.C.B.:

- Put a Cloth over the equipment. Put the MAIN (1), (5), and POWER (1), (2) P.C.B.s together with the heat sink upright on the Cloth and check them. (Fig. 6)
- Reconnect all cables (connectors) that have been disconnected.
- When connecting the flat cable, use care for the polarity.
- The P.C.B. removed from the rear panel does not work because its grounding is loose. Be sure to connect the ground of each P.C.B. to the chassis or GND with a jumper wire or the like.

P.C.B.チェックをする場合には

- 布を敷きます。その上にMAIN(1)、(5)、POWER(1)、(2) P.C.B.をヒートシンクと一緒に立ててチェックします。(Fig. 6)
- 外したケーブル(コネクタ)をすべて接続してください。
- フラットケーブルを接続する際、極性に注意してください。
- リアパネルから外したP.C.B.はアースが浮いて動作しませんので、各P.C.B.のアースをリード線等でシャーシまたはGNDに接続してください。

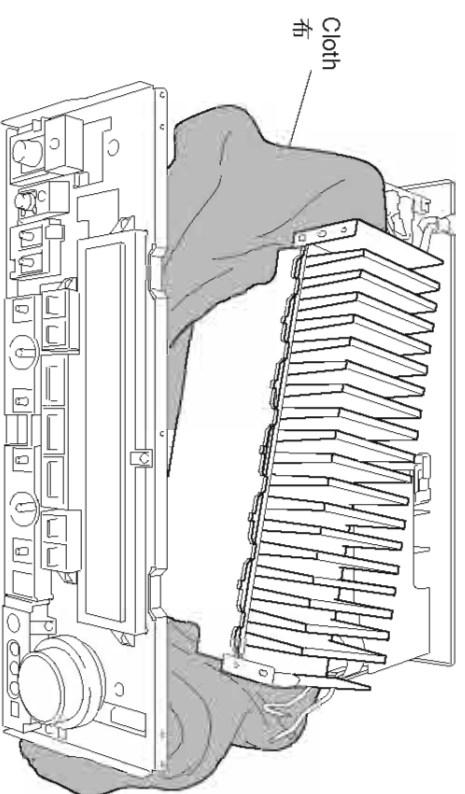

Fig. 6

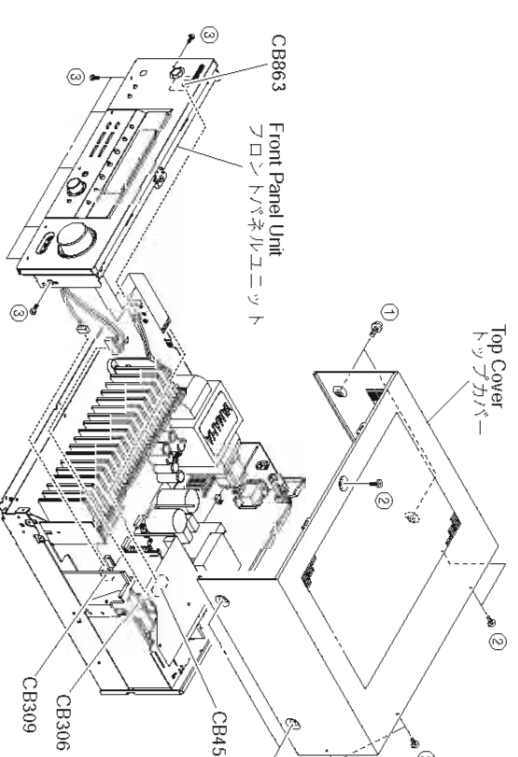

Fig. 1

3. Removal of DSP P.C.B.

- Remove 1 screw (④). (Fig. 2)
- Remove 7 (HTR-5850), 5 (RX-V457, HTR-5840) screws (⑤). (Fig. 3)
- Remove CB2 and CB11. (Fig. 2)
- Lift up the SUBTRANS (2) P.C.B. and remove the CB1. (Fig. 2)
- Remove the DSP P.C.B. with the Support/DSP. (Fig. 2)

3. DSP P.C.B.の外し方

- ④のネジ1本を外します。(Fig. 2)
- ⑤のネジ6本を外します。(Fig. 3)
- CB2、CB11を外します。(Fig. 2)
- SUBTRANS(2) P.C.B.を上部に浮かせCB1を外します。(Fig. 2)
- DSP P.C.B.をサポート/DSPと共に取外します。(Fig. 2)

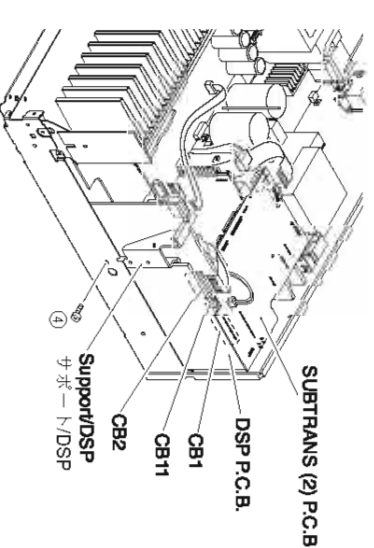
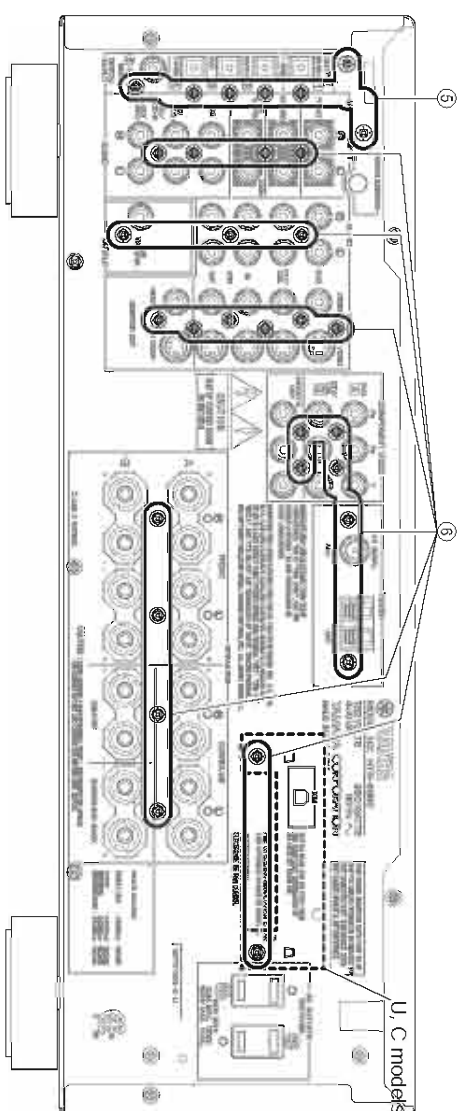
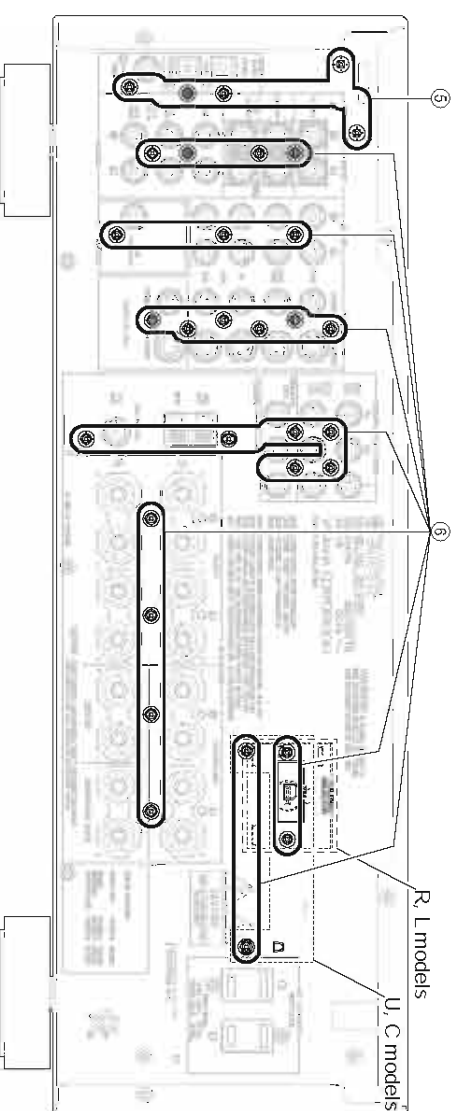

Fig. 2

HTR-5850



RX-V457/HTR-5840



DSP-AX457

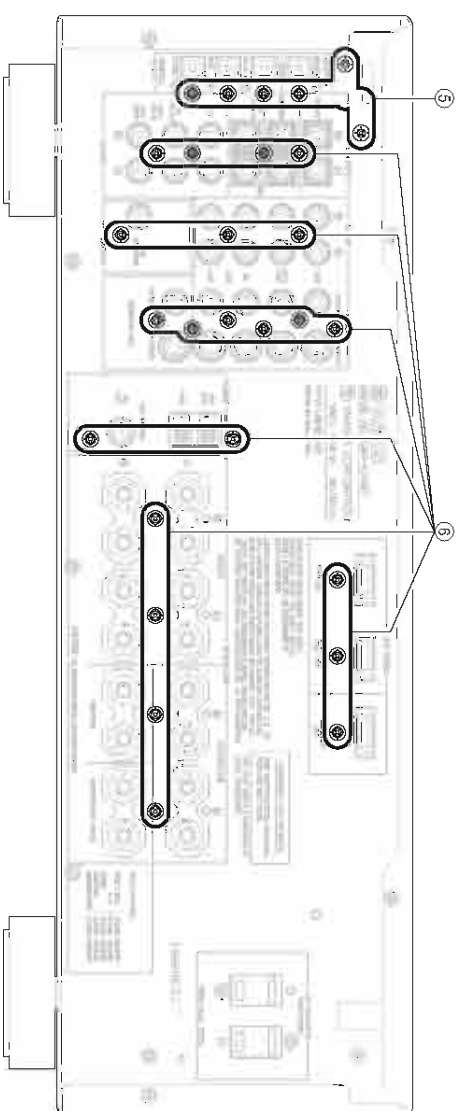

Fig. 3

4. Removal of FUNCTION, SUBTRANS (2), (3), (6), (7), (9), (9), (10), CONVERSION (HTR-5850), XM (U, C models) P.C.B.s and Tuner

- a. Remove CB21, CB24 (U, C models), CB307, CB351, CB452, CB453 and CB706 (HTR-5850). (Fig. 4)
- b. Remove 25 (U, C, R, L models), 23 (T, K, A, B, G, E models) screws (⑨). (Fig. 3)
- c. Remove FUNCTION, SUBTRANS (2), (3), (4) (RX-V457/HTR-5840), (6), (7), (9), (10) (HTR-5850), CONVERSION (HTR-5850), XM (U, C models) P.C.B.s and Tuner. (Fig. 4)

HTR-5850

4. FUNCTION, SUBTRANS (2), (3), (6), (7), (9), VIDEO, TUNERの取り外し方

- a. CB307, CB351, CB452, CB453を取り外します。(Fig. 4)
- b. ⑨の本ネを取り外します。(Fig. 3)
- c. FUNCTION, SUBTRANS (2), (3), (6), (7), (9), VIDEO, TUNERを取り外します。(Fig. 4)

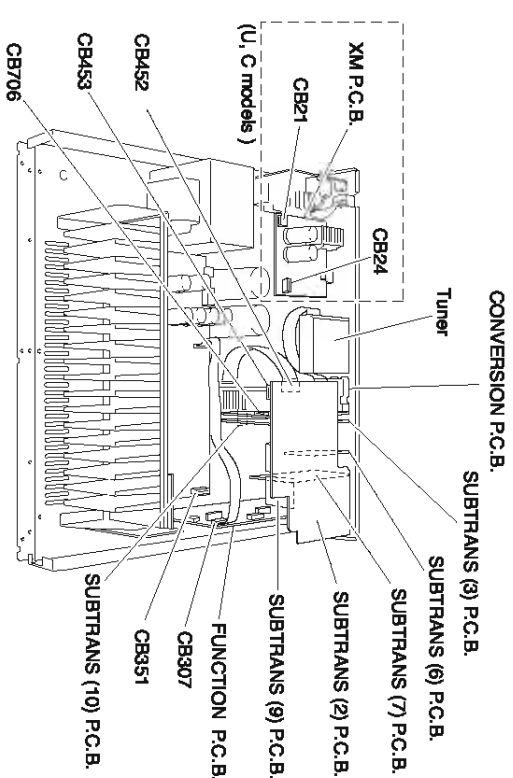

RX-V457/HTR-5840/DSP-AX457

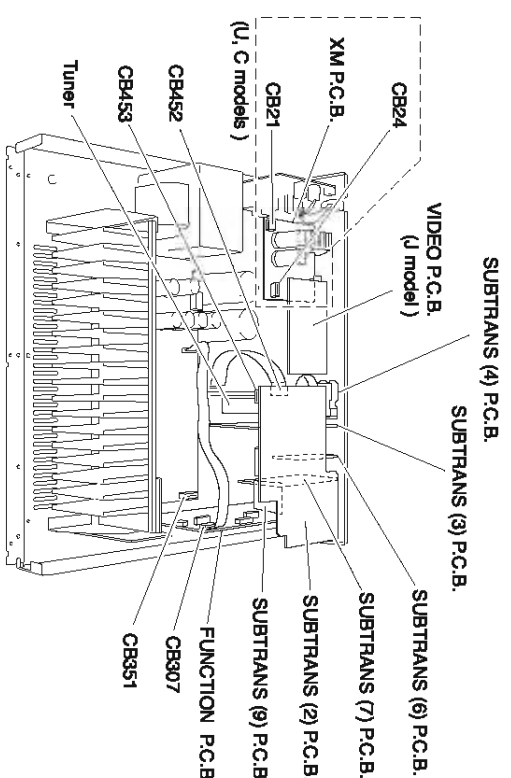

Fig. 4

5. Removal of MAIN (1), (5) and POWER (1), (2) P.C.B.s

- a. Remove CB354. (Fig. 5)
- b. Remove 2 screws (⑦), 2 screws (⑧) and 3 screws (⑨). (Fig. 5)
- c. Remove MAIN (1), (5) and POWER (1), (2) P.C.B.s. (Fig. 5)

5. MAIN (1)、(5)、POWER (1)、(2) P.C.B.の外し方

- a. CB354を外します。(Fig. 5)
- b. ⑦のネジ2本、⑧のネジ2本、⑨のネジ3本を外します。(Fig. 5)
- c. MAIN (1)、(5)、POWER (1)、(2) P.C.B.を取り外します。(Fig. 5)

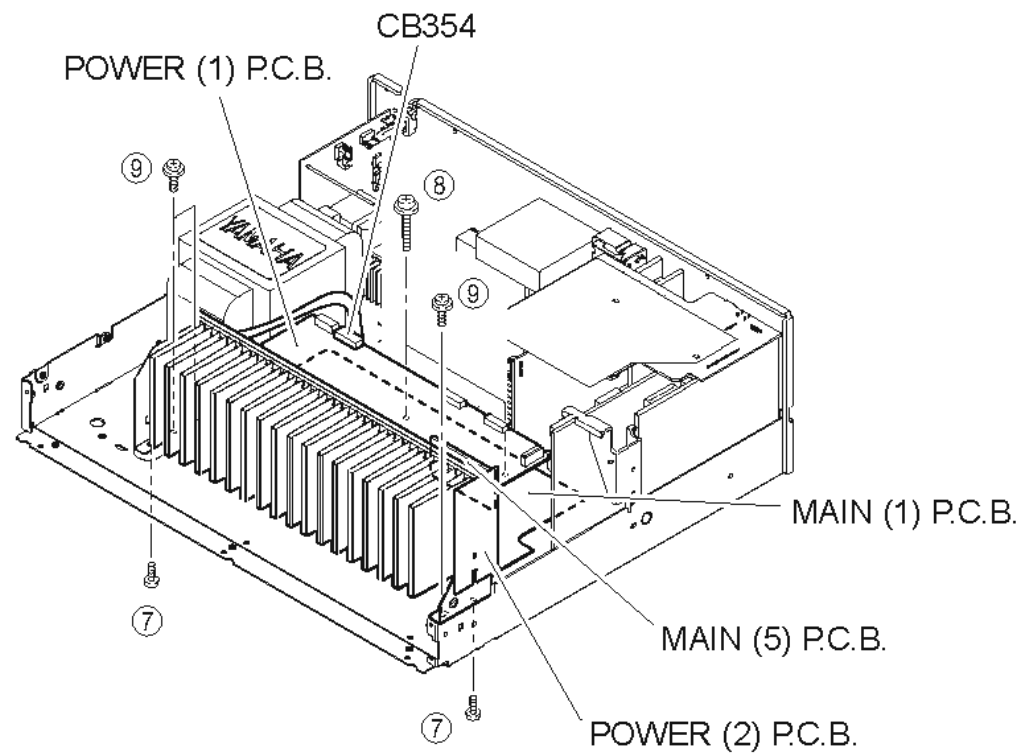

Fig. 5

When checking the P.C.B.:

- Put a Cloth over the equipment. Put the MAIN (1), (5) and POWER (1), (2) P.C.B.s together with the heat sink upright on the Cloth and check them. (Fig. 6)
- Reconnect all cables (connectors) that have been disconnected.
- When connecting the flat cable, use care for the polarity.
- The P.C.B. removed from the rear panel does not work because its grounding is loose. Be sure to connect the ground of each P.C.B. to the chassis or GND with a jumper wire or the like.

P.C.B.チェックをする場合には

- 布を敷きます。その上にMAIN(1)、(5)、POWER(1)、(2)P.C.B.をヒートシンクと一緒に立ててチェックします。(Fig. 6)
- 外したケーブル(コネクタ)をすべて接続してください。
- フラットケーブルを接続する際、極性に注意してください。
- リアパネルから外したP.C.B.はアースが浮いて動作しませんので、各P.C.B.のアースをリード線等でシャーシまたはGNDに接続してください。

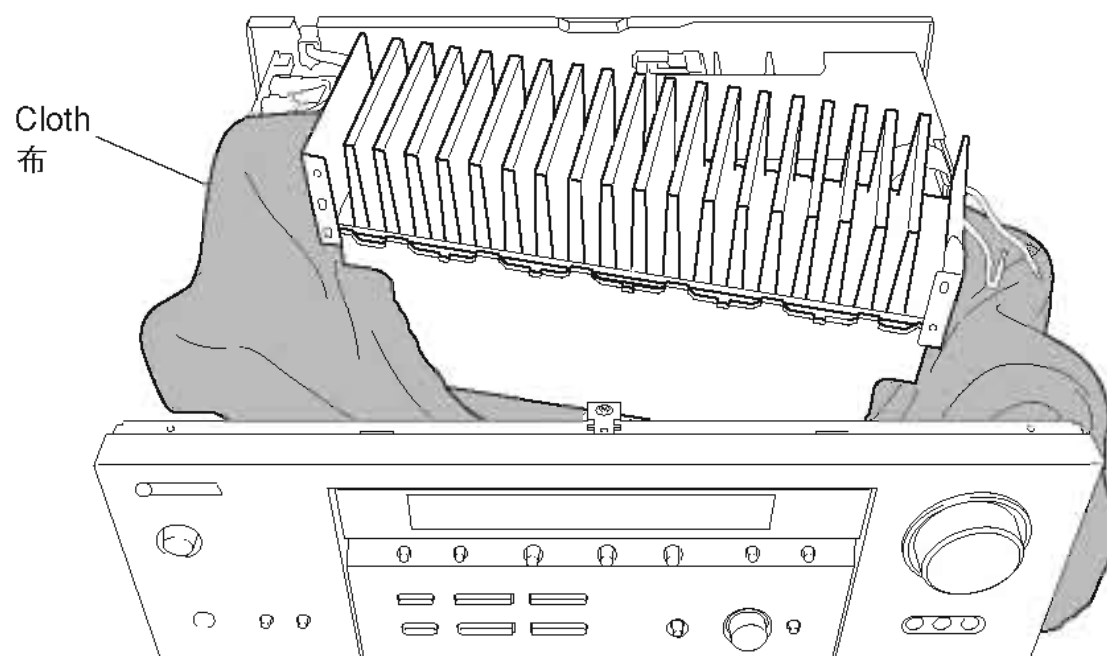

Fig. 6

■ SELF DIAGNOSIS FUNCTION (DIAG) / 自己診断機能 (ダイアグ)

This unit has self diagnosis functions that are intended for inspection, measurement and location of faulty point.

There are 20 DIAG menu items, each of which has sub-menu items.

Listed in the table below are menu items and sub-menu items.

Note that not all menu items listed will apply to the models covered in this service manual.

本機には、検査、測定、不良個所の発見を目的にした自己診断機能(ダイアグ)があります。

ダイアグメニューは20個あり、そのそれぞれにサブメニューがあります。(ダイアグのメニュー操作は本体で行います。) 下表はメニュー一覧です。

下表の全メニュー項目が、このサービスマニュアル記載のモデルに適用されるとは限りません。

No	DIAG menu	sub-menu
1	BYPASS 1. ANALOG BYPASS	1. ANALOG BYPASS
		2. DSP BYPASS
2	RAM THROUGH 2. RAM MARGIN	1. RAM MARGIN
		2. RAM FULL BIT
3	PRO LOGIC 3. PRO LOGIC	1. PRO LOGIC
4	SPEAKERS SET 4. FRNT: SML 0dB	1. FRNT: SML 0dB
		2. CENTER: NONE
		3. LFE/B: FRNT
		4. Pres Mix: 5ch
		5. FRNT GAIN1
		6. FRNT GAIN2
		7. SURR B Check
5	EXT-INPUT 5. XCH INPUT_6	1. 6CH INPUT_6
		2. 6CH INPUT_8
6	MIC CHECK 6. MIC CHK --dB	MIC CHK --dB (Not applied to these models / このモデルには適用されません)
7	DISPLAY CHECK 7. VFD CHECK	1. VFD CHECK (Initial display / 初期表示)
		2. VFD DISP OFF (All segments OFF / 全セグメント消灯)
		3. VFD DISP ALL (All segments ON 100% / 全セグメント点灯100%)
		4. VFD DIMMER (All segments ON 50% / 全セグメント点灯50%)
		5. CHECKED PATTERN (ON in lattice / 格子状点灯)
8	MANUAL TEST 8. TEST ALL	1. TEST ALL
		2. TEST FRNT L
		3. TEST CENTER
		4. TEST FRNT R
		5. TEST SURR R
		6. TEST SB R
		7. TEST SB L
		7. TEST SURR L
9	FACTORY PRESET 9. PRESET INHI	1. PRESET INHI (memory initialization inhibited / メモリーの初期化禁止)
		2. PRESET RSRV (memory initialized / メモリーの初期化)
10	AD DATA CHECK DC:98% PS: 38%	1. DC/PS (protection)
		2. THM
		3. IMP SW/POWER LIMIT
		4. K0/K1 (panel key)
11	V_CONV_STATUS L:11111111	1. LOW BYTE (Not applied to these models / このモデルには適用されません)
		2. HIGH BYTE (Not applied to these models / このモデルには適用されません)
12	XM 12. XMS1xxxxxxxx	1. XMS1 (Not applied to these models / このモデルには適用されません)
		2. XMS2 (Not applied to these models / このモデルには適用されません)

No	DIAG menu	sub-menu
13	IF STATUS IS1:440308C000	1. DST
		2. DMD
		3. DIF
		4. PC
		5. CS1
		6. CS2
		7. DEI
		8. BS1
		9. BS2
		10. BS3
		11. BS4
		12. BS5
		13. BS6
		14. BS7
		15. BS8
		16. MTT
		17. BGI
		18. DGI
14	DSP RAM CHECK TI BUS:NoEr	1. TI BUS
15	SWFR CUT OFF 15.LFE LPF 40	1. LFE LPF
		2. LFE HPF
16	PROTECTION SETTING Not applied to these models. このモデルには適用されません。	1. PS L
		2. PS H
		3. DC L
		4. DC H
		5. TEMP
		6. PL_8_M_L:
		7. PL_8_M_H
		8. PL_8_N_L:
		9. PL_8_N_H:
		10. PL_6_M_L:
		11. PL_6_M_H:
		12. PL_6_N_L:
		13. PL_6_N_H:
17	PROTECTION HISTORY	1. HISTORY 1
		2. HISTORY 2
		3. HISTORY 3
		4. HISTORY 4
18	SOFT SWITCH 18.SW :PCB	1. SW MODE
		2. MODEL SETTING
		3. DESTINATION
		4. TUNER DESTINATION
		5. TUNER TYPE
		6. VIDEO FORMAT
		7. ZONE 2
		8. AAC
		9. TUNER
		10. ZONE 2 AMP
		11. OSD
		12. YPAO
19	ROM VERSION/ CHECK SUM/PORT VER. XXXXX	1. U-COM VERSION
		2. U-COM CHECK SUM ALL/PROGRAM
		3. OPE/DSP/XM
		4. AAC PORT
		5. TI (DSP) VERSION
		6. TI (DSP) SUM
		7. EE SUM
20	DSP WRITTING	1. TI Boot

● Starting DIAG

Press the "STANDBY/ON" key while simultaneously pressing those two keys of the main unit as indicated in the figure below.

Keys of main unit / 本体キー

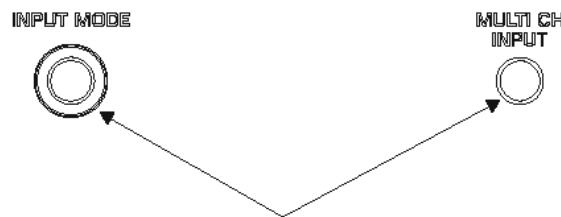

Turn on the power while pressing these keys.
これらのキーを同時に押しながら、パワーオンする。

● Starting DIAG in the protection cancel mode

If the protection function works and causes hindrance to trouble diagnosis, cancel the protection function as described below, and it will be possible to enter the DIAG mode. (The protection functions other than the excess current detect function will be disabled.)

Press the "STANDBY/ON" key while simultaneously pressing those two keys indicated in the figure above. At this time, keep pressing those two keys for 3 seconds or longer.

In this mode, the "SLEEP" segment of the FL display of the main unit flashes to indicate that the mode is DIAG mode with the protection functions disabled.

CAUTION!

Using this product with the protection function disabled may cause damage to itself. Use special care for this point when using this mode.

● Canceling DIAG

[1] Before canceling DIAG, execute setting for FACTORY PRESET of DIAG menu No.9 (Memory initialization inhibited or Memory initialized).

* In order to keep the user memory stored, be sure to select PRESET INHIBITED (Memory initialization inhibited).

[2] Turn off the power by pressing the "STANDBY/ON" key of the main unit.

● ダイアグの起動

本体の下図に示すキーを同時に押しながら "STANDBY/ON" キーを押すと、ダイアグが起動します。

● プロテクション解除モードでの起動

プロテクションが動作することにより、故障箇所の診断に支障をきたすような場合は、次の方法によりプロテクションを解除した状態でダイアグモードに入ることができます。(過電流検出以外のプロテクション動作を解除する)

上図のキーを同時に押しながら "STANDBY/ON" キーを押します。このとき、上図のキーを3秒以上押し続けてください。このモードでは本体FLの "SLEEP" セグメントが点滅し、プロテクションを解除した状態でのダイアグモードであることを知らせます。

注意!

プロテクションを解除した状態でのダイアグモードは、危険な状態でもプロテクションが作動しないため、動作させると、機器を破壊することがあります。このモードを使用する場合は十分注意してください。

● ダイアグの解除

① ダイアグを解除する前に、ダイアグメニューNo.9のFACTORY PRESET (メモリーの初期化禁止/またはメモリーの初期化)の設定をします。

※ ユーザーメモリーを保持したい場合は、必ずPRESET INHIBITED(メモリー初期化禁止)を選択してください。

② 本体の "STANDBY/ON" キーを押し、パワーオフにします。

● Display provided when DIAG started

The FL display of the main unit displays the protection function history data and the version (1 alphabet) and the DIAG menu [sub-menu (ANALOG BYPASS) of DIAG menu No.1 BYPASS] a few seconds later.

● ダイアグ起動時の表示

本体のFLディスプレイにプロテクション履歴情報とバージョン(英1文字)が表示され、数秒後にダイアグメニュー(No.1 BYPASSのサブメニューANALOG BYPASS)になります。

When there is no history of protection function:

プロテクション履歴がない場合:

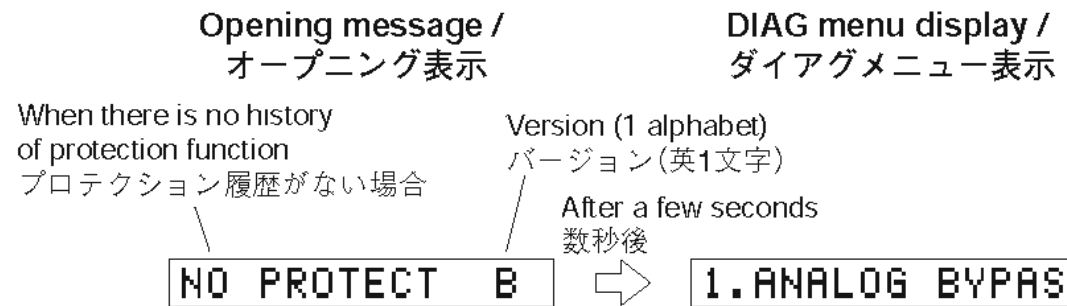

When there is a history of protection function:

プロテクション履歴がある場合:

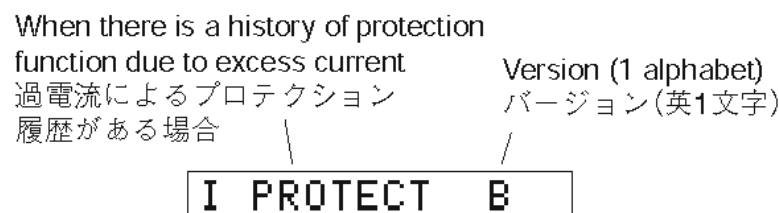

Cause: An excessive current flowed through the power amplifier.

Supplementary information: As current of the power transistor is detected, the abnormal channel can be identified by checking the current detect transistor.

Turning on the power without correcting the abnormality will cause the protection function to work immediately and the power supply will instantly be shut off.

原因：パワーアンプに過電流が流れた。

補足：パワートランジスタの電流を検出していますので、電流検出トランジスタをチェックすれば異常チャンネルが特定できます。

異常状態のままパワーオンすると、瞬時にプロテクションがかかり、すぐに電源が切れます。

Note)

- Applying the power to a unit without correcting the abnormality can be dangerous and cause additional circuit damage.
- The output transistors in each amplifier channel should be checked for damage before applying any power.
- Amplifier current should be monitored by measuring across the emitter resistors for each channel.

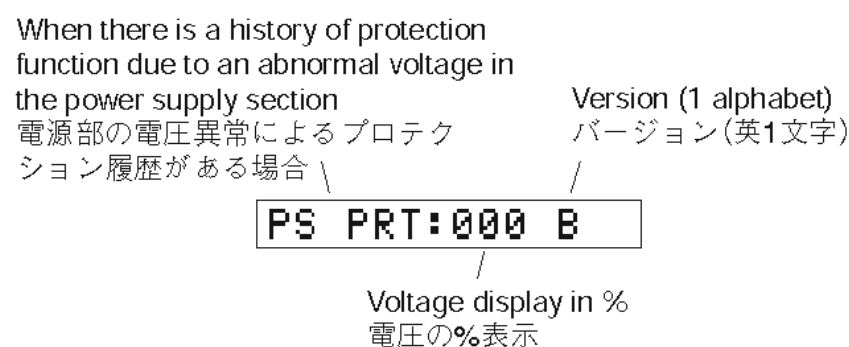

Cause: The voltage in the power supply section is abnormal.

Supplementary information: The abnormal voltage is displayed in % based on 5V as 100%.

Turning on the power without correcting the abnormality will cause the protection function to work 1 second later and the power supply will be shut off.

原因：電源部の電圧が異常。

補足：異常時の電圧の状態を、5Vを100%とした値で%表示します。

異常状態のままパワーオンすると、1秒後にプロテクションがかかり、電源が切れます。

RX-V557/HTR-5850/DSP-AX557
RX-V457/HTR-5840/DSP-AX457

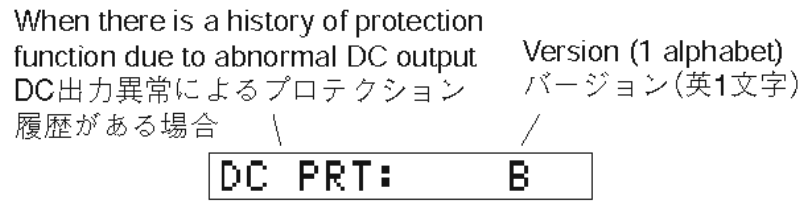

Cause: DC output of the power amplifier is abnormal.
Supplementary information: The abnormal voltage is displayed in % based on 5V as 100%.

原因： パワーアンプのDC出力が異常。
補足： 異常時の電圧の状態を、5Vを100%とした値で%表示します。
異常状態のままパワーオンすると、3秒後にプロテクションがかかり、電源が切れます。

Turning on the power without correcting the abnormality will cause the protection function to work 3 seconds later and the power supply will be shut off.

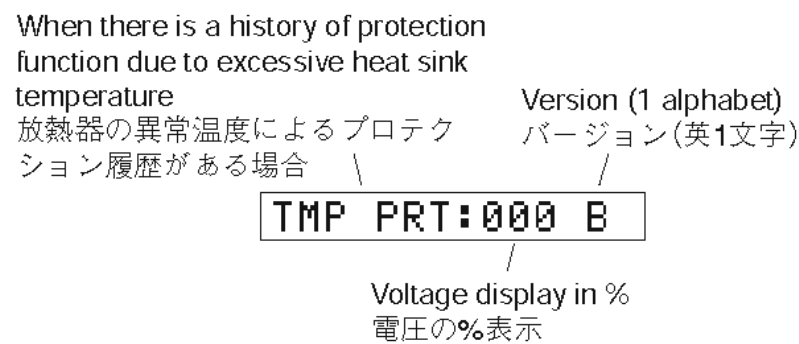

Cause: The temperature of the heat sink is excessively high.
Supplementary information: The abnormal voltage is displayed in % based on 5V as 500%.

原因： 放熱器の温度が異常。
補足： 異常時の電圧の状態を、5Vを500%とした値で%表示します。
異常状態のままパワーオンすると、1秒後にプロテクションがかかり、電源が切れます。

Turning on the power without correcting the abnormality will cause the protection function to work 1 second later and the power supply will be shut off.

- * Additional causes of protection can be due to loose connections, associated components, CPU, etc.
- * For the protection voltage value, refer to DIAG menu No.10 described later.

- ※ 前記の異常原因の他に、コネクタのほすれやCPU周辺などに原因がある場合があります。
- ※ プロテクションの電圧値に関しては、後述のダイアグメニューNo.10を参照してください。

● History of protection function

When the protection function has worked, its history is stored in memory with a backup. Even if no abnormality is noted while servicing the unit, an abnormality which has occurred previously can be defined as long as the backup data has been stored.
The history of the protection function is cleared when DIAG is cancelled by selecting PRESET RESERVED (Memory initialized) of DIAG menu No.9 or when the backup data is erased.

● プロテクションの履歴

プロテクションが働いた場合、履歴をバックアップして記憶しています。サービスのときに異常が認められなくても、バックアップが残っていれば、お客様のところで起きた異常を区別できます。
プロテクションの履歴は、ダイアグメニューNo.9でPRESET RESERVED(メモリーの初期化)を選んでダイアグを解除した場合や、バックアップが消えたときにはクリアされます。

● Display during menu operation

During the DIAG operation, the function at work is indicated on the FL indicator. The contents displayed during the function operation are described in the later section on details of functions.

● メニュー動作中の表示

ダイアグ中、本体のFLディスプレイに動作中の機能が表示されます。機能動作中の表示内容については、後述の機能詳細で記述します。

● Operation procedure of DIAG menu and SUB-MENU

There are 20 MENU items, each of which has some SUB-MENU items.

DIAG menu selection

Main unit: Select the menu using the PROGRAM knob.

SUB-MENU selection

Main unit: Select the sub-menu using ▷ (Forward) and ◁ (Reverse) keys of PRESET/TUNING.

● ダイアグメニューとサブメニューの操作

ダイアグにはNo.1~20のメニューがあり、そのそれぞれにサブメニューがあります。

ダイアグメニューの選択

本体キーでの操作：PROGRAMツマミで選択します。

サブメニューの選択

本体キーでの操作：PRESET/TUNING ▷ (順送り), ◁ (逆送り) キーで選択します。

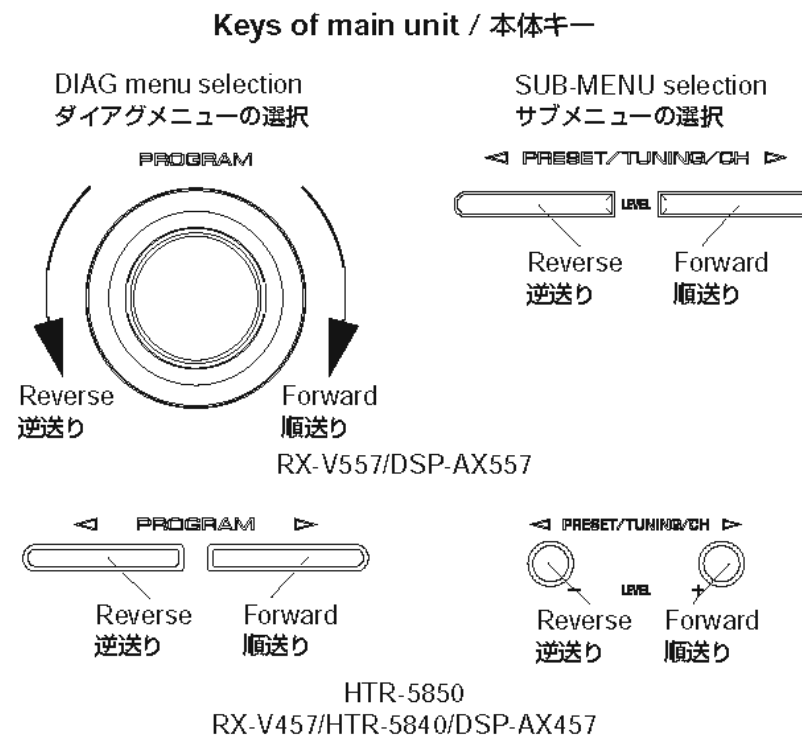

● Functions in DIAG mode

In addition to the DIAG menu items, functions as listed below are available.

- Input selection, 6CH input
- Center/Rear/Rear Center/Sub-woofer level adjustment
- Speaker relay control of A and B
- Muting
- Power on/off
- Master volume

* Functions related to the tuner and the set menu are not available.

* It is possible to confirm Menu No.13 IF STATUS while keeping the signal process (operation status) of each DIAG menu by using the INPUT MODE key of the main unit.

● ダイアグ中の機能

ダイアグメニューの他に、以下の機能が動作します。

- インプット切り換え、6CHインプット
- センター、リア、リアセンター、サブウーファーレベル調整
- スピーカーリレーA/B
- ミューティング
- パワーオン/オフ
- マスターボリューム

※ チューナー関連、セットメニュー関連は機能しません。

※ 本体のINPUT MODEキーにより、各ダイアグメニューの信号処理(動作状態)を維持したままメニューNo.13 "IF STATUS"の確認ができます。

● Initial settings used to start DIAG

The following settings are used when starting DIAG.

When DIAG is canceled, these settings are restored to those before starting DIAG.

- Master volume: -20 dB
- Input: DVD (MULTI CH INPUT OFF)
- Effect level: 0 dB
- Audio mute: OFF
- Speaker relay of A and B: ON
- Speaker setting: LARGE / BASS OUT = SWFR
- DIAG menu: BYPASS (1. ANALOG BYPASS)

● ダイアグ開始時の初期設定

ダイアグ開始時に以下のような設定になります。ダイアグ解除時にはダイアグ開始前の状態に戻ります。

- マスターボリューム：-20 dB
- インプット：DVD (MULTI CH INPUT オフ)
- エフェクトレベル：0 dB
- オーディオミュート：オフ
- スピーカーリレーA/B：ON
- スピーカー設定：LARGE / BASS OUT = SWFR
- ダイアグメニュー：BYPASS (1. ANALOG BYPASS)

RX-V557/HTR-5850/DSP-AX557
RX-V457/HTR-5840/DSP-AX457

• Details of DIAG menu

1. BYPASS

Using the sub-menu, it is possible to select analog bypass output or DSP bypass output.

ANALOG BYPASS

1. ANALOG BYPASS

Reference data
INPUT: DVD ANALOG
SUBWOOFER OUTPUT: 50 Hz, Others: 1 kHz

Input level	Volume	SPEAKERS OUT				SUBWOOFER OUTPUT
		FRONT L/R	CENTER	SURROUND L/R	SURROUND BACK L/R	
Both ch, -20 dBm	+6.0 dB	+13.0 dBm	- ∞	- ∞	- ∞	- ∞

DSP BYPASS

1. DSP BYPASS

Reference data
INPUT: DVD ANALOG
SUBWOOFER OUTPUT: 50 Hz, Others: 1 kHz

Input level	Volume	SPEAKERS OUT				SUBWOOFER OUTPUT
		FRONT L/R	CENTER	SURROUND L/R	SURROUND BACK L/R	
Both ch, -20 dBm	+6.0 dB	- ∞	- ∞	- ∞	- ∞	- ∞

ANALOG BYPASS

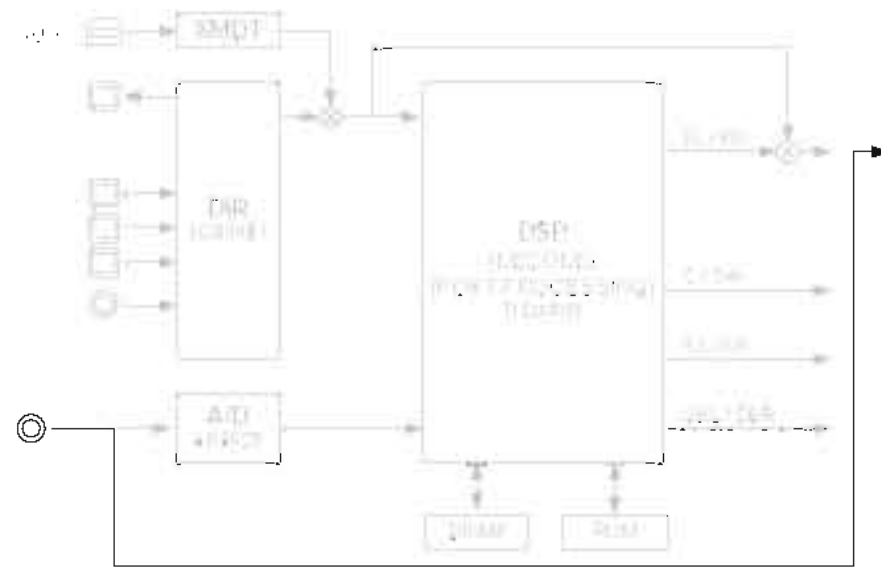

(Shaded items not used in this example)

DSP BYPASS

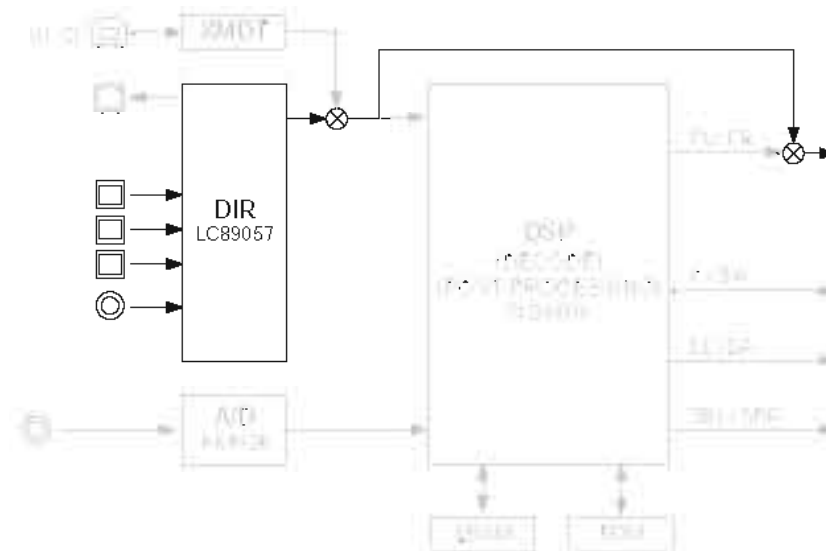

(Shaded items not used in this example)

● ダイアグメニュー詳細

1. BYPASS

サブメニューによりANALOG BYPASS/DSP BYPASSが選択可能です。

ANALOG BYPASS

DSP BYPASS

2. RAM THROUGH

Using the sub-menu, it is possible to select margin output or full-bit output.

RAM MARGIN

Following head margin is reserved.

FRONT	CENTER	SURROUND	SURROUND BACK	SUBWOOFER
+15.0 dB	+14.0 dB	+9.0 dB	+7.5 dB	+18.0 dB

2. RAM MARGIN

Reference data

INPUT: DVD ANALOG

SUBWOOFER OUTPUT: 50 Hz, Others: 1 kHz

Input level	Volume	SPEAKERS OUT				SUBWOOFER OUTPUT
		FRONT L/R	CENTER	SURROUND L/R	SURROUND BACK L/R	
Both ch, -20 dBm	+6.0 dB	+13.0 dBm	+13.0 dBm	+13.0 dBm	+13.0 dBm	+0.5 dBm

RAM FULL BIT

No head margin is reserved expect SW.

FRONT	CENTER	SURROUND	SURROUND BACK	SUBWOOFER
0 dB	0 dB	0 dB	0 dB	+18 dB

2. RAM FULL BIT

Reference data

INPUT: DVD ANALOG

SUBWOOFER OUTPUT: 50 Hz, Others: 1 kHz

Input level	Volume	SPEAKERS OUT				SUBWOOFER OUTPUT
		FRONT L/R	CENTER	SURROUND L/R	SURROUND BACK L/R	
Both ch, -20 dBm	+6.0 dB	+6.0 dBm	+13.0 dBm	+13.0 dBm	+13.0 dBm	+0.5 dBm

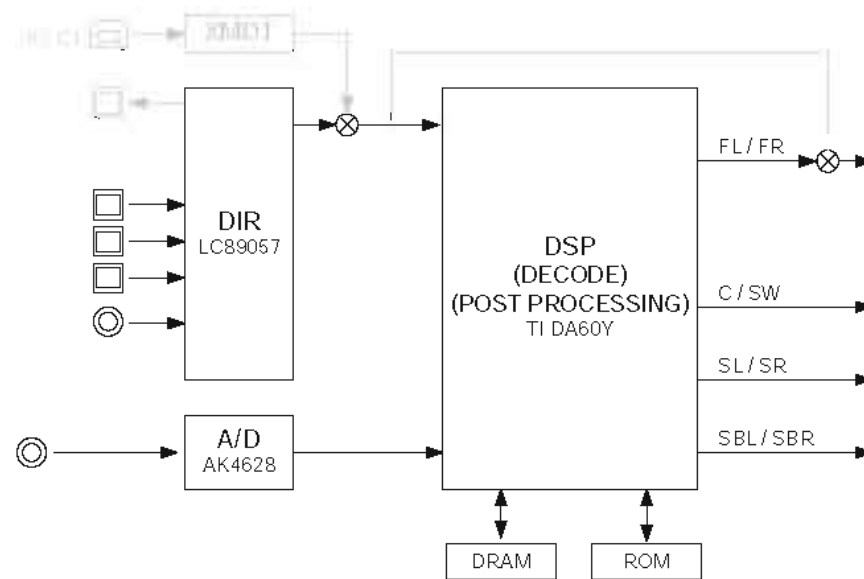

(Shaded items not used in this example)

When input source is stereo, output signal is shaken down as below.
2ch信号入力時、以下のように信号を振り分けて出力します。

- Front L → Center / Surround L / Surround Back L, R
- Front R → Surround R
- Front L +10 dB → SWFR

RX-V557/HTR-5850/DSP-AX557
RX-V457/HTR-5840/DSP-AX457

3. PRO LOGIC

Dolby PRO LOGIC is applied to input stereo source.

3. PRO LOGIC

3. PRO LOGIC

入力2ch信号にDolby PRO LOGIC処理を行います。

Reference data

INPUT: DVD ANALOG

SUBWOOFER OUTPUT: 50 Hz, Others: 1 kHz

Input level	Volume	SPEAKERS OUT				SUBWOOFER OUTPUT
		FRONT L/R	CENTER	SURROUND L/R	SURROUND BACK L/R	
Each ch, -20 dBm	+6.0 dB	+9.5 dBm	- ∞	- ∞	- ∞	- ∞
Both ch, -20 dBm	+6.0 dB	- ∞	+13.0 dBm	- ∞	- ∞	- ∞

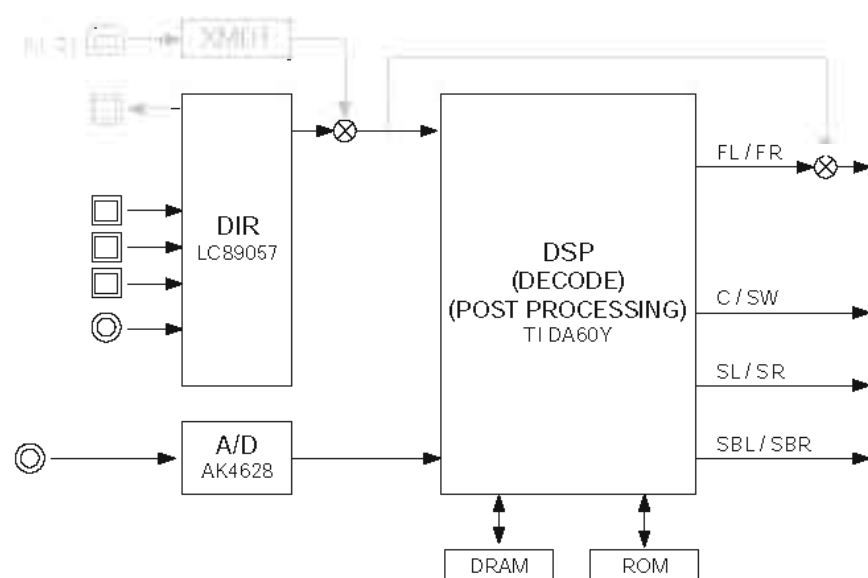

(Shaded items not used in this example)

4. SPEAKERS SET

The analog switch settings for each sub-menu are as shown in the table below.

4. SPEAKERS SET

各サブメニューにおけるアナログスイッチの設定は以下の通りです。

Sub-menu	FRONT	CENTER	SUR.	SUR.B	LFE
1 FRNT: SML 0 dB	SMALL	LARGE	LARGE	LARGE	SWFR
2 CENTER: NONE	LARGE	NONE	LARGE	LARGE	SWFR
3 LFE/B: FRNT	LARGE	SMALL	SMALL	SMALL	FRONT
4 Pre Mix: 5ch	LARGE	LARGE	LARGE	LARGE	SWFR
5 Front GAIN 1	LARGE	LARGE	LARGE	LARGE	SWFR
6 Front GAIN 2	LARGE	LARGE	LARGE	LARGE	SWFR
7 SURR B Check	LARGE	LARGE	LARGE	LARGE	SWFR

LARGE: This mode is used with a speaker with high bass reproduction performance (a large unit). Full bandwidth signals are output.

SMALL: This mode is used with a speaker with low bass reproduction performance (a small unit). The signals of 80 Hz or less are mixed into the channel specified by LFE/BASS.

NONE: This mode is used with no center speaker. The center content is reduced by 3 dB and distributed to FRONT L/R.

LARGE: 低音再生能力の高い(ユニットの大きい)スピーカーを使用するモードです。全帯域が出力されます。

SMALL: 低音再生能力の低い(ユニットの小さい)スピーカーを使用するモードです。80 Hz以下がLFE/BASSで指定したチャンネルにミックスされます。

NONE: スピーカーを使用しないモードです。センター成分は-3 dBされて、FRONT L/R に振り分けられます。

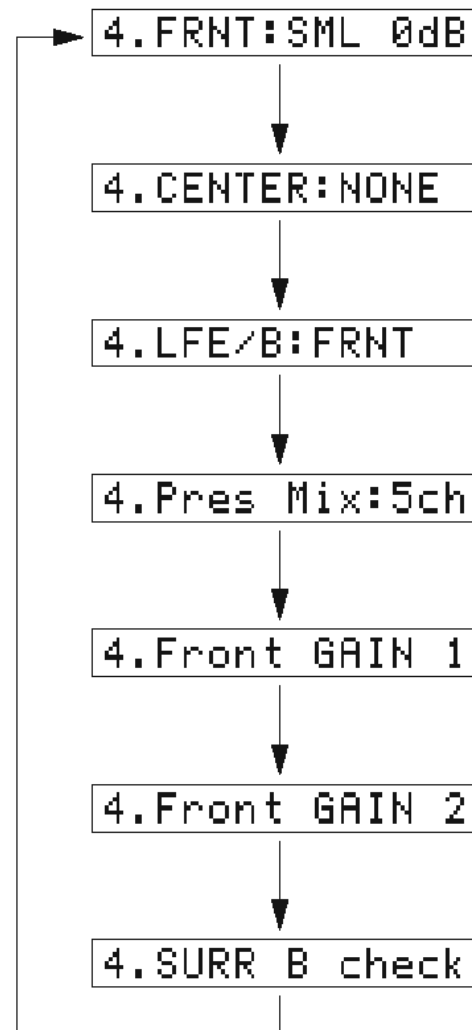

Reference data

INPUT: DVD ANALOG (Both ch)

SUBWOOFER OUTPUT: 50 Hz, Others: 1 kHz

	Sub-menu	Input level	Volume	SPEAKER OUT				SUBWOOFER OUTPUT
				FRONT	CENTER	SURROUND	SURROUND BACK	
1	FRONT: SML 0dB	Both ch, -20 dBm	+6.0 dB	+13.0 dBm	+13.0 dBm	+13.0 dBm	+13.0 dBm	+3.5 dBm
2	CENTER: NONE	Both ch, -20 dBm	+6.0 dB	+10.0 dBm	+13.0 dBm	+13.0 dBm	+13.0 dBm	+0.5 dBm
3	LFE/B: FRNT (1 kHz)	Both ch, -20 dBm	+6.0 dB	- ∞	+13.0 dBm	+13.0 dBm	+13.0 dBm	- ∞
	LFE/B: FRNT (50 Hz)	Both ch, -20 dBm	+6.0 dB	+25.0 dBm	+3.5 dBm	+3.5 dBm	+3.5 dBm	- ∞
4	Pres Mix: 5ch	Both ch, -20 dBm	+6.0 dB	- ∞	+13.0 dBm	+17.5 dBm	+13.0 dBm	-0.5 dBm
5	Front Gain 1	Both ch, -20 dBm	+6.0 dB	+20.0 dBm	+13.0 dBm	+13.0 dBm	+13.0 dBm	-0.5 dBm
6	Front Gain 2	Both ch, -20 dBm	+6.0 dB	+20.0 dBm	+13.0 dBm	+13.0 dBm	+13.0 dBm	-0.5 dBm
7	SURR B check	Both ch, -20 dBm	+6.0 dB	- ∞	- ∞	- ∞	+13.0 dBm	- ∞

RX-V557/HTR-5850/DSP-AX557
RX-V457/HTR-5840/DSP-AX457

5. EXTERNAL INPUT

The signal input through the 6CH INPUT terminals is output.

The speaker impedance can be selected.

XCH INPUT_6

5.XCH INPUT_6

Reference data

INPUT: MULTI CH INPUT

SUBWOOFER OUTPUT: 50 Hz, Others: 1 kHz

Input level	Volume	SPEAKERS OUT				SUBWOOFER OUTPUT
		FRONT L/R	CENTER	SURROUND L/R	SURROUND BACK L/R	
Both ch, -20 dBm	+6.0 dB	+13.0 dBm	+13.0 dBm	+13.0 dBm	- ∞	+10.0 dBm

5. EXTERNAL INPUT

6CH入力した信号が出力されます。

6オーム、8オームが選択できます。

XCH INPUT_6

XCH INPUT_8

5.XCH INPUT_8

Reference data

INPUT: MULTI CH INPUT

SUBWOOFER OUTPUT: 50 Hz, Others: 1 kHz

Input level	Volume	SPEAKERS OUT				SUBWOOFER OUTPUT
		FRONT L/R	CENTER	SURROUND L/R	SURROUND BACK L/R	
Both ch, -20 dBm	+6.0 dB	+13.0 dBm	+13.0 dBm	+13.0 dBm	- ∞	+10.0 dBm

XCH INPUT_8

6. MIC CHECK

MIC CHK --dB

Not applied to these models.

6.MIC CHK --dB

6. MIC CHECK

MIC CHK --dB

このモデルには適用されません。

7. DISPLAY CHECK

This program is used to check the FL display section. The display condition varies as shown below according to the sub-menu operation. The signals are processed using EFFECT OFF (The L/R signal is output using ANALOG MAIN BYPASS.)

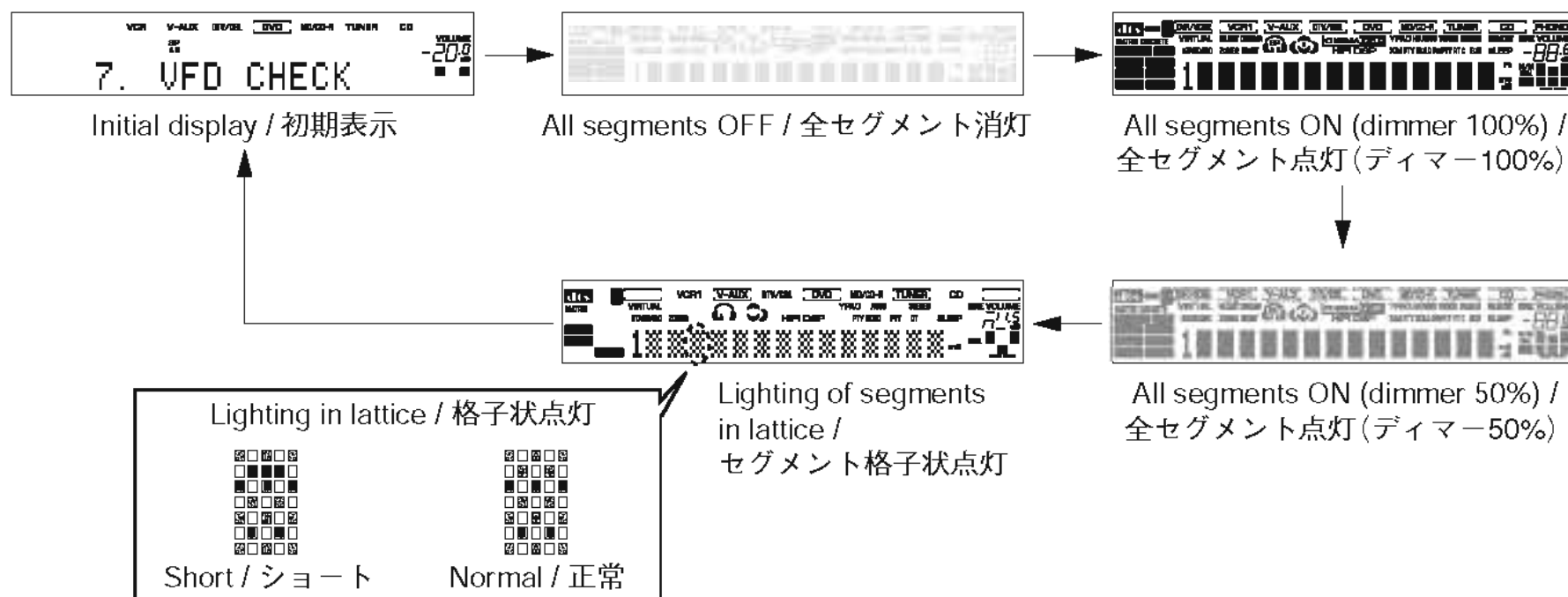

Segment conditions of the FL driver and the FL tube are checked by turning ON and OFF all segments. Next, the operation of the FL driver is checked by using the dimmer control. Then a short between segments next to each other is checked by turning ON and OFF all segments alternately (in lattice). (In the above example, the segments in the second row from the top are shorted.)

7. DISPLAY CHECK

FL表示部のチェックプログラムです。サブメニュー操作により、表示状態が以下のように変わります。信号処理はEFFECT OFF (ANALOG MAIN BYPASSでL/Rを出力)です。

全セグメント消灯・全セグメント点灯によりFLドライバー、FL管のセグメントの不良を確認します。次に、ディマーコントロールによってFLドライバーの動作チェックを行います。さらに全セグメントを交互(格子状)に点灯/消灯することで、隣り合うセグメントのショートをチェックします。(上図の例では、上から2行目のセグメントがショートしています。)

8. MANUAL TEST

The noise generator circuit built into the DSP outputs the test noise through the channels specified by the sub-menu.

The noise frequency for LFE is 35 to 250 Hz. Other than that, the center frequency is 800 Hz

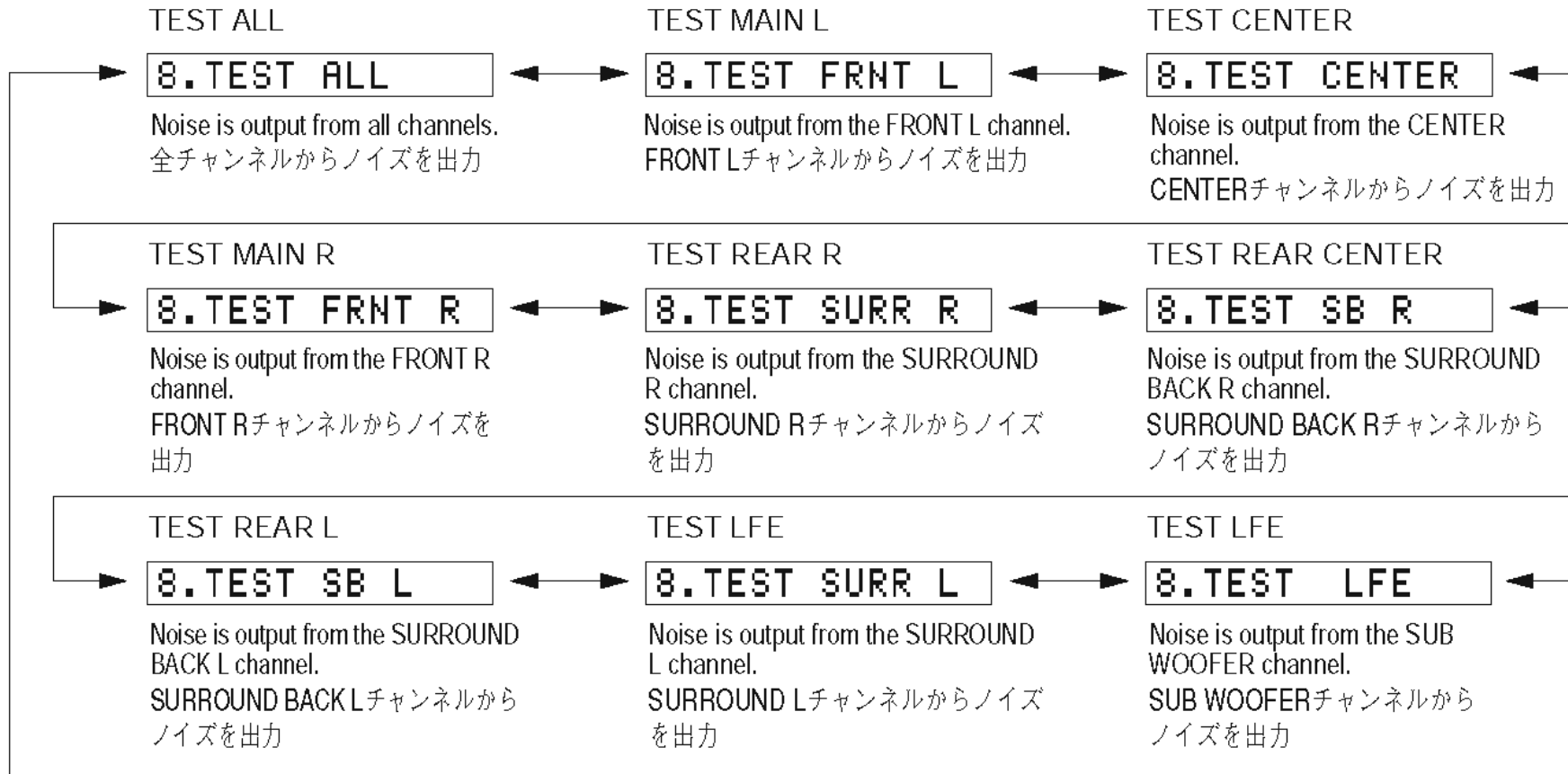

8. MANUAL TEST

DSP内蔵のノイズ発生回路によって、サブメニューで指定したチャンネルへテストノイズを出力します。

LFE用のノイズ周波数は35~250 Hz、それ以外は中心周波数800 Hzとなります。

9. FACTORY PRESET

This menu is used to reserve and inhibit initialization of the back-up RAM. The signals are processed in the same way as EFFECT OFF. (The L/R signal is output using ANALOG MAIN BYPASS.)

9. FACTORY PRESET

バックアップ用RAM (音場プログラムのパラメーターやセットメニュー内容など)の初期化を予約/禁止します。信号処理はEFFECT OFFと同じです (ANALOG MAIN BYPASSで、L/Rを出力)。

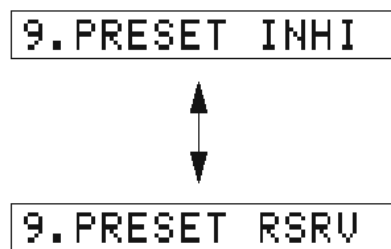

PRESET INHIBIT (Initialization inhibited) / PRESET INHIBIT (初期化禁止)
RAM initialization is not executed. Select this sub-menu to protect the values set by the user. RAMの初期化は行われません。ユーザーの設定値を保護するときは、こちらを選択してください。

PRESET RESERVED (Initialization reserved) / PRESET RESERVED (初期化予約)
Initialization of the back-up RAM is reserved. (Actually, initialization is executed the next time that the power is turned on.) Select this sub-menu to reset to the original factory settings or to reset the RAM.
バックアップRAMの初期化が予約されます。(実際に初期化されるのは、次回の電源投入時です。)工場出荷時やRAMをリセットしたいときは、こちらを選択してください。

CAUTION: Before setting to the PRESET RESERVED for initialization, write down the existing preset memory content of the Tuner in a table as shown below. (This is because initialization will cause the user memory content to be erased.)

注意： PRESET RESERVEDを選んで初期化をする前に、チューナーのユーザーメモリー内容を下表に書き写してください。(初期化をすると、ユーザーメモリーの内容は消えてしまいます。)

Preset group	P1	P2	P3	P4	P5	P6	P7	P8
A								
B								
C								
D								
E								

• PRESET STATIONS / プリセット局

STATION		FM FACTORY PRESET DATA (MHz)		
PAGE	NO.	U, C	R, T, K, A, B, G, E, L	J
A/C/E	1	87.5	87.5	76.0
	2	90.1	90.1	83.0
	3	95.1	95.1	84.0
	4	98.1	98.1	86.0
	5	107.9	108.0	90.0
	6	88.1	88.1	78.0
	7	106.1	106.1	88.0
	8	107.9	108.0	82.1

STATION		AM FACTORY PRESET DATA (kHz)		
PAGE	NO.	U, C, R, T, K	A, B, G, E, L	J
B/D	1	630	630	630
	2	1080	1080	1080
	3	1440	1440	1440
	4	530	531	531
	5	1710	1611	1611
	6	900	900	900
	7	1350	1350	1350
	8	1400	1404	1404

10. AD DATA CHECK

This menu is used to display the A/D conversion value of the terminals which detect panel keys of the main unit and protection functions in % using the sub-menu. During signal processing, the condition before execution is maintained.

When K0/K1 menu is selected, keys become non-operable due to detection of the values of all keys. However, it is possible to advance to the next sub-menu by turning the VOLUME knob of the main unit. When using this function, note that turning the VOLUME knob more than 2 clicks will cause the volume value to change.

* The numeric value in the figure is an example for reference.

DC/PS (protection detection)

DC: DC protection value

Normal value: 1 to 13 (Reference: 5V=100%)

When DC is out of the normal value range, the protection function works to turn off the power.

PS: Power supply voltage protection value

Normal value: 18 to 33 (Reference: 5V=100%)

When PS is out of the normal value range, the protection function works to turn off the power.

DC:008 PS:030

THM (temperature detection)

THM: 500% display of the voltage based on the temperature detected value. Reference voltage : 5V
For the normal value, refer to the table below.

THM: 100

Destination	Normal Voltage
U, C, T, K, A, B, G, E, J	9-177
R, L	9-167

10. AD DATA CHECK

本体パネルキー、プロテクションなどを検出している端子のA/D変換の値を、サブメニューで%表示します。信号処理は実行前の状態を維持します。

K0/K1のメニューにすると、全キーの値を検出するためキー操作はできなくなりますが、本体のVOLUMEを回すことにより、次のサブメニューに進めることができます。このとき2クリック以上回すと、ボリューム値が変化するので注意してください。

※図中の数値は参考例です。

DC/PS (プロテクションの検出)

DC: DCプロテクションの値

正常値1~13(基準電圧 5V=100%)

DCは正常値を外れるとプロテクションが働き、電源オフされます。

PS: 電源電圧プロテクションの値

正常値18~33(基準電圧 5V=100%)

PSは正常値を外れるとプロテクションが働き、電源オフされます。

THM (温度検出)

THM: 温度検出値で電圧の500%表示、基準電圧は5V
正常値は下表参照。

**RX-V557/HTR-5850/DSP-AX557
RX-V457/HTR-5840/DSP-AX457**

IMP SW/POWER LIMIT

(Impedance/power limiter detection)

IMP: Not applied to these models.

PL: Power limiter detection value

The voltage value of pin No. 92 of IC451 is displayed, using 5V/256 as standard.

The port (No.3) output is controlled by using the input voltage value of pin No. 92 of IC451.

IMP:8 PL:55%

Not applied to these models.

K0/K1 (Panel key of main unit)

A/D of the key fails to function properly when the standard value is deviated. In this case, check the constant of partial pressure resistor, solder condition, etc. Refer to table 1.

K0:100%K1:100%

[Table 1]

RX-V557 (U, C, A, B, G, E models)

Display (%)	K0	K1
0 - 6	MAIN POWER	Z2 POWER
7 - 13	-	-
14 - 21	-	-
22 - 31	-	-
32 - 41	INPUT MODE	MULTI CH INPUT
42 - 53	STRAIGHT	FM/AM
54 - 63	TONE CONTROL	A/B/C/D/E
64 - 72	PRESET/TUNING	PRESET/TUNING ◀
73 - 80	SPEAKER B	PRESET/TUNING ▶
81 - 88	SPEAKER A	MEMORY
89 - 95	-	TUNING MODE
96 - 100	KEY OFF	KEY OFF

[Table 1]

HTR-5850/RX-V457/HTR-5840/DSP-AX457 (U, C, R, T, K, A, L, J models)

Display (%)	K0	K1
0 - 6	PROGRAM ◀	-
7 - 13	PROGRAM ▶	-
14 - 21	BASS/TREBLE -	-
22 - 31	BASS/TREBLE +	-
32 - 41	INPUT MODE	MULTI CH INPUT
42 - 53	STRAIGHT	FM/AM
54 - 63	TONE CONTROL	A/B/C/D/E
64 - 72	PRESET/TUNING	PRESET/TUNING ◀
73 - 80	SPEAKER B	PRESET/TUNING ▶
81 - 88	SPEAKER A	MEMORY
89 - 95	-	TUNING MODE
96 - 100	KEY OFF	KEY OFF

IMP SW/POWER LIMIT

(インピーダンス/パワーリミッターの検出)

IMP: このモデルには適用されません。

PL: パワーリミッター検出の値

IC451 92ピンの入力電圧値を5V/256を基準にして表示します。

IC451 92ピンの入力電圧値により、ポート(3ピン)を制御します。

K0/K1 (本体パネルキー)

キーのA/Dは基準値から外れると、正常な動きをしません。Table 1をご覧ください。各キーの分圧抵抗の定数、ハンダ不良等の確認をしてください。

[Table 1]

RX-V557/DSP-AX557 (R, T, K, L, J models)

Display (%)	K0	K1
0 - 6	-	-
7 - 13	-	-
14 - 21	-	-
22 - 31	-	-
32 - 41	INPUT MODE	MULTI CH INPUT
42 - 53	STRAIGHT	FM/AM
54 - 63	TONE CONTROL	A/B/C/D/E
64 - 72	PRESET/TUNING	PRESET/TUNING ◀
73 - 80	SPEAKER B	PRESET/TUNING ▶
81 - 88	SPEAKER A	MEMORY
89 - 95	-	TUNING MODE
96 - 100	KEY OFF	KEY OFF

[Table 1]

RX-V457/HTR-5840 (B, G, E models)

Display (%)	K0	K1
0 - 6	PROGRAM ◀	EON
7 - 13	PROGRAM ▶	MODE
14 - 21	BASS/TREBLE -	PTY SEEK START
22 - 31	BASS/TREBLE +	PTY SEEK MODE
32 - 41	INPUT MODE	MULTI CH INPUT
42 - 53	STRAIGHT	FM/AM
54 - 63	TONE CONTROL	A/B/C/D/E
64 - 72	PRESET/TUNING	PRESET/TUNING ◀
73 - 80	SPEAKER B	PRESET/TUNING ▶
81 - 88	SPEAKER A	MEMORY
89 - 95	-	TUNING MODE
96 - 100	KEY OFF	KEY OFF

11. V CONV STATUS

Not applied to these models.

LOW BYTE DATA

L:11111111

HIGH BYTE DATA

H:11111111

11. V CONV STATUS

このモデルには適用されません。

LOW BYTE DATA

HIGH BYTE DATA

12. XM STATUS

Not applied to these models.

12. XM STATUS

このモデルには適用されません。

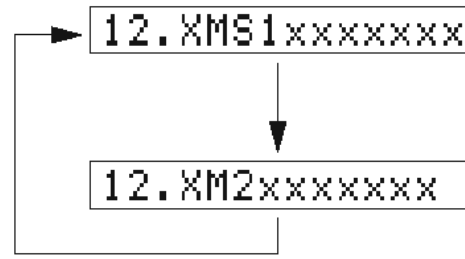

13. IF STATUS (Input function status)

Using the sub-menu, the status data is displayed one after another in the hexadecimal notation.
 During signal processing, the status before execution of this menu is maintained.

* Numeric values in the figure example are for reference.

13. IF STATUS

サブメニュー操作により、以下のステータス情報を順次16進数で表示します。信号処理は、本メニュー実行前の状態を維持します。

※図中の数値は参考例です。

DST: DSP status

DST: DSPステータス

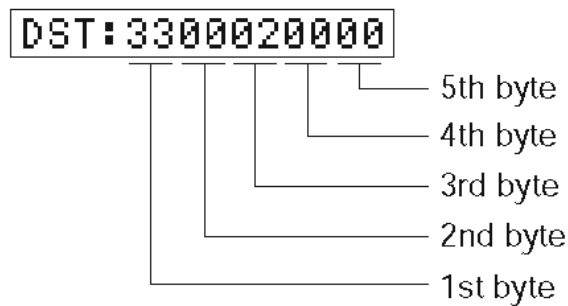

<1st byte> Digital input/output setting value
 Upper 4 bits: REC OUT selected /
 lower 4 bits: INPUT selected

<第1バイト>デジタル入出力設定値
 上位4 bit REC OUT選択 /
 下位4 bit INPUT選択

Value	Choice	Preset name
0	NONE	
1	OPT FRONT	V-AUX
2	OPT 1	MD/CD-R
3	OPT 2	DVD
4	OPT 3	DTV/CBL
8	COAX 1	CD
9	COAX 2	DVD

RX-V557/HTR-5850/DSP-AX557
RX-V457/HTR-5840/DSP-AX457

<2nd byte> / <第2バイト>

Fs information of reproduction signal /
再生信号のFs情報

Display	Fs (kHz)
00	Analog
01	32 kHz
02	44.1 kHz
03	48 kHz
04	64 kHz
05	88.2 kHz
06	96 kHz
07	128 kHz
08	176.4 kHz
09	192 kHz
0A	Unknown NRM
0B	Unknown DBL
0C	Unknown QUAD
0D	Unknown
0E	Undefined

<3rd byte> / <第3バイト>

Audio code mode information of
reproduction signal /
再生信号のオーディオコードモード情報

Display	Audio code
00	1+1
01	1/0
02	2/0
03	3/0
04	2/1
05	3/1
06	2/2
07	3/2
08	2/3
09	3/3
0A	3/4
0B	over 6.1
0C	Milti-Mono
0D	Milti-PCE
0E	Unknown
0F	Undefined

<4rd byte> / <第4バイト>

Format information of reproduction signal /
再生信号のフォーマット情報

Display	Signal format
00	Analog
01	Err
10	PCM Audio
20	Digital Data
21	IEC1937
22	None PCM
23	Unknown
50	dts
51	dts-CD
52	dts 96/24
54	dts-ES (Matrix)
58	dts-ES (Discrete)
5C	dts-ES (Both)
60	AAC
C0	Dolby Digital
C1	Dolby Digital Karaoke
C4	Dolby Digital EX
FF	Undefined

<5th byte> / <第5バイト>

Signal processing status information /
信号処理ステータス情報

bit	Fs (kHz)
bit 7	Digital mute
bit 6	-
bit 5	6.1 (7.1) processing
bit 4	Analog mute
bit 3	-
bit 2	PCM through
bit 1	-
bit 0	dts analog mute

DMD: Decoder mode information
Not applied to these models.

DMD: デコーダー情報
このモデルには適用されません。

DMD: 03C00000

DIF: DIR information
Not applied to these models.

DIF: DIR情報
このモデルには適用されません。

DIF: 1401000600

PC: Preamble C information
Not applied to these models.

PC: Preamble C情報
このモデルには適用されません。

PC: 0000

CS1, 2: Channel status information
Not applied to these models.

CS1、2: チャンネルステータス情報
このモデルには適用されません。

CS1: 0000000000 - - - - - **CS2: 00**

DEI: Decoder information
Not applied to these models.

DEI: デコーダー情報
このモデルには適用されません。

DEI:0808000600

BS1-8: Bit stream information
Not applied to these models.

BS1-8: ビットストリーム情報
このモデルには適用されません。

BS1:0000000000 ----- **BS8:00**

MTT: Mute Trigger
Not applied to these models.

MTT: Mute Trigger
このモデルには適用されません。

MTT:0018001820

DGI: Digital information
Not applied to these models.

DGI: DIGITAL系情報
このモデルには適用されません。

DGI:FFFFFFFF

14. DSP BUS CHECK

This menu is used to self-diagnose whether or not the bus connection for the TI (DA60Y) and the external ROM/RAM is made properly.

When no error is detected, "NoEr" appears on display.

TI BUS:NoEr

No error detected.
不良検出なし

or

TI BUS:Boot

When this indication is displayed with in seconds or displayed alternately "NoEr" and "Boot", it is highly possible that there are errors.

数秒間この状態、またはNoErと交互に表示される場合、異常が発生している可能性があります。

14. DSP BUS CHECK

TI(DA60Y)と外付けROM/RAMとのバス接続の正否を自己診断します。

エラーが検出されなかった場合は、“NoEr”と表示されます。

15. SWFR CUT OFF

The cut off frequency setting of LFE.

Low-pass filter setting.

It can be selected 40 Hz to 200 Hz every 10 Hz by the STRAIGHT key.

High-pass filter setting.

It can be selected 40 Hz to 200 Hz every 10 Hz and through by the STRAIGHT key.

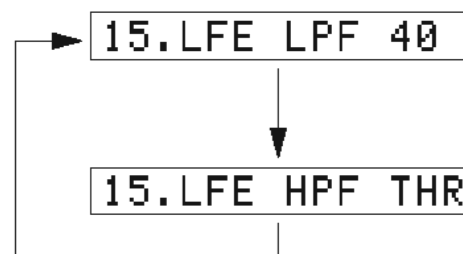

15. SWFR CUT OFF

LFE出力のカットオフ周波数を設定できます。

ローパスフィルタの設定です。

STRAIGHTキーにより、40 Hz~200 Hzまで10 Hz単位で変更できます。

ハイパスフィルタの設定です。

STRAIGHTキーにより、40 Hz~200 Hzまで10 Hz単位とスルーに変更できます。

16. PROTECTION SETTING

Not applied to these models.

16. PROTECTION SETTING

このモデルには適用されません。

17. PROTECTION HISTORY

Four protection histories are display.

17. PROTECTION HISTORY

過去のプロテクション履歴を4つまで表示します。

RX-V557/HTR-5850/DSP-AX557
RX-V457/HTR-5840/DSP-AX457**18. SOFT SW**

Note) Changing the function setting may hinder the proper operation.

This menu is used to switch the function settings on P.C.B. through the software so as to activate the product.

The protection function follows the P.C.B. settings. When connected to AC or in the maker preset state, the unit is initialized to the P.C. B. setting. Display of each function after initialization varies depending on settings on P.C.B. The operation mode can be changed by selecting the sub-menu and then using the STRAIGHT key.

SW MODE: PCB, MODEL or FNC can be selected.

18.SW : PCB

MODEL SETTING: V757, V657, H5860, V557, V457, H5850 or V357 can be selected. (SW MODE: Selectable when MODEL has been selected.)

18.MODEL:V557

DESTINATION: J, U, C, R, T, K, A, B, G (E) or L can be selected. (SW MODE: Selectable when MODEL has been selected.)

18.DEST :U

TUNER DEST INATION: J, UC, R, ABG or RL can be selected. (SW MODE: Selectable when FNC has been selected.)

18.TuDst:UC

TUNER TYPE: NRM, RDS or XM can be selected. (SW MODE: Selectable when FNC has been selected.)

18.TuTyp:XM

VIDEO FORMAT: NTSC or PAL can be selected. (SW MODE: Selectable when FNC has been selected.)

18.VIDEO:NTSC

ZONE2: NOT or EXIST can be selected. (SW MODE: Selectable when FNC has been selected.)

18.ZONE2:NOT

18. SOFT SW

注) 機能設定を変更した場合、正常に動作しないことがあります。

P.C.B.上の機能設定をソフト的に切り替えて、製品を動作させる機能です。

プロテクション機能は、P.C.B.の設定にしたがいます。AC接続またはメーカープリセットで、P.C.B.の設定に初期化されます。初期化後の各機能の表示は、P.C.B.上の設定によります。操作は、サブメニューを選んだ後、STRAIGHTキーで切り替えま

SW MODE : PCB、MODELまたはFNCを選択できます。

MODEL SETTING : V757、V657、H5860、V557、V457、H5850、V357のいずれかを選択できます。(SW MODE : MODEL時選択できます。)

DESTINATION : J、U、C、R、T、K、A、B、G(E)、Lのいずれかを選択できます。(SW MODE : MODEL時選択できます。)

TUNER DEST INATION : J、UC、R、ABG、RLのいずれかを選択できます。(SW MODE : FNC時選択できます。)

TUNER TYPE : NRM、RDS、XMのいずれかを選択できます。(SW MODE : FNC時選択できます。)

VIDEO FORMAT : NTSCまたはPALを選択できます。(SW MODE : FNC時選択できます。)

ZONE2 : NOTまたはEXISTを選択できます。(SW MODE : FNC時選択できます。)

AAC: NOT or EXIST can be selected. (SW MODE: Selectable when FNC has been selected.)

AAC : NOTまたはEXISTを選択できます。(SW MODE : FNC時選択できます。)

18.AAC : NOT

TUNER: NOT or EXIST can be selected. (SW MODE: Selectable when FNC has been selected.)

TUNER : NOTまたはEXISTを選択できます。(SW MODE : FNC時選択できます。)

18.TUNER:EXIST

ZONE2 AMP: NOT or EXIST can be selected. (SW MODE: Selectable when FNC has been selected.)

ZONE2 AMP : NOTまたはEXISTを選択できます。(SW MODE : FNC時選択できます。)

18.Z2AMP:NOT

OSD: NOT or EXIST can be selected. (SW MODE: Selectable when FNC has been selected.)

OSD : NOTまたはEXISTを選択できます。(SW MODE : FNC時選択できます。)

18.OSD : NOT

YPAO: NOT or EXIST can be selected. (SW MODE: Selectable when FNC has been selected.)

YPAO : NOTまたはEXISTを選択できます。(SW MODE : FNC時選択できます。)

18.YPAO : NOT

19. SOFTWARE VERSION

The version, checksum and the port specified by the microprocessor are displayed. The signal is processed using EFFECT OFF. The checksum is obtained by adding the data at every 16 bits for each program area and expressing the result as a 4-figure hexadecimal data.

* Numeric values in the figure example are for reference.

19. SOFTWARE VERSION

ソフトウェアのバージョン、チェックサム、マイコンの指定ポートを表示します。

信号はエフェクトOFFです。チェックサムは、プログラムエリア別にデータを16ビットごとに加算していき、4桁の16進データで現したものです。

※図中の数値は参考例です。

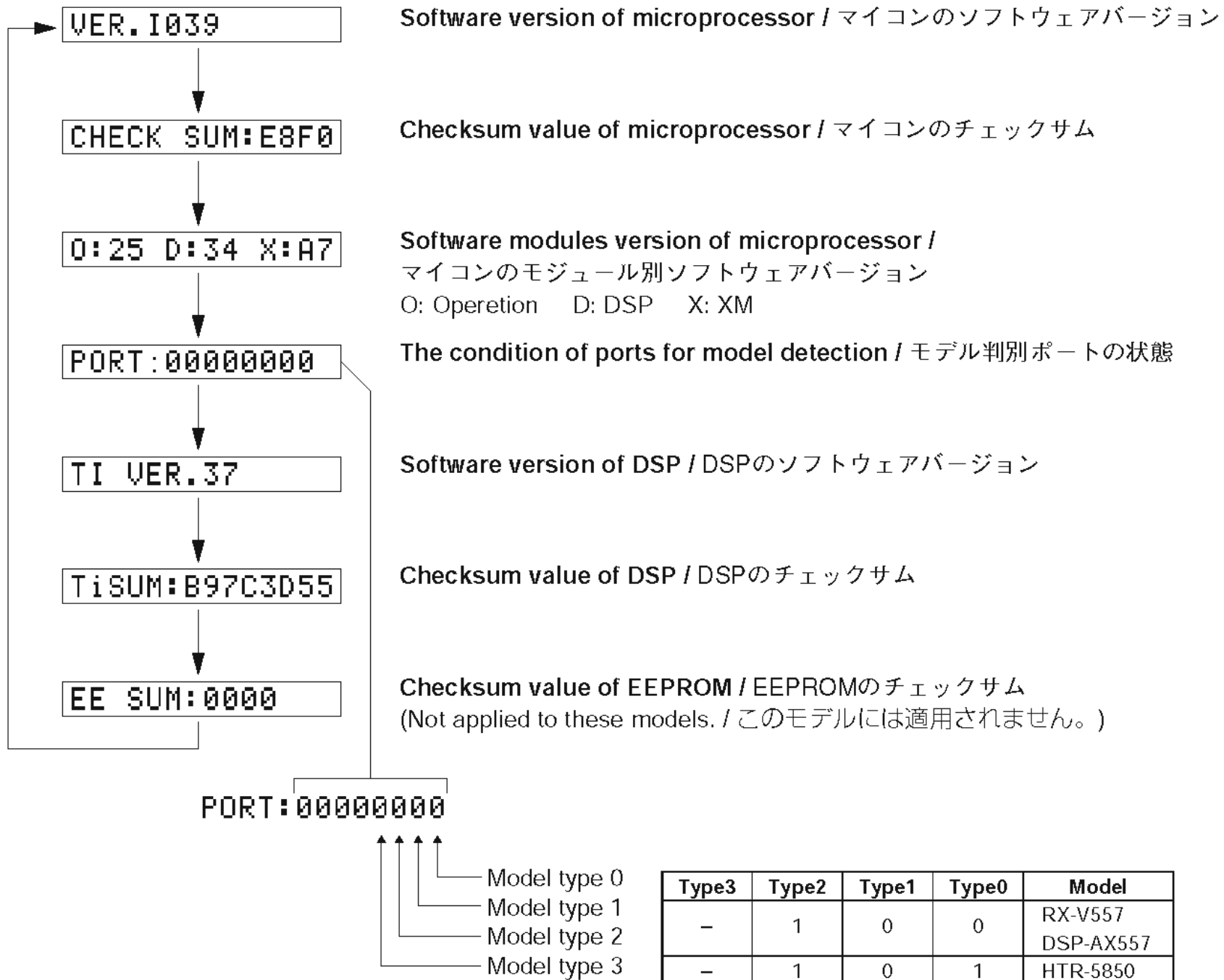

Type3	Type2	Type1	Type0	Model
-	1	0	0	RX-V557 DSP-AX557
-	1	0	1	HTR-5850
-	1	1	1	RX-V457 HTR-5840 DSP-AX457

20. DSP SOFTWARE REWRITE

The rewriting mode of DSP software.
(Not applied to these models.)

20. DSP SOFTWARE REWRITE

DSPのソフトウェア書き換えモードです。
(このモデルには適用されません。)

■ AMP ADJUSTMENT / アンプ部調整

Confirmation of Idling Current of MAIN (1) P. C. B.

- Right after power is turned on, confirm that each measured voltage across the terminals of R45 (FRONT Lch), R46 (FRONT Rch), R50 (CENTER), R47 (SURROUND Lch), R48 (SURROUND Rch), R49 (SURROUND BACK Rch) is between 0.1 mV and 10.0 mV.
- If it exceeds 10.0 mV, open (cutoff) R38 (FRONT Lch), R39 (FRONT Rch), R37 (CENTER), R34 (SURROUND Lch), R35 (SURROUND Rch), R36 (SURROUND BACK Rch) and reconfirm the voltage.

Attention

If the measured voltage exceeds 10.0 mV. after an amplifier repair, first check for a defective component before cutting the bias resistor.

- Confirm that the voltage is 0.2 mV ~ 15.0 mV. after 60 minutes.

メイン(1)基板のアイドル電流の確認

- 電源投入直後、R45 (FRONT Lch)、R46 (FRONT Rch)、R50 (CENTER)、R47 (SURROUND Lch)、R48 (SURROUND Rch)、R49 (SURROUND BACK Rch)の端子間電圧を測定し、0.1 mVから10.0 mVの間であることを確認してください。
 - 電圧が10 mVを超えている場合は、R38 (FRONT Lch)、R39 (FRONT Rch)、R37 (CENTER)、R34 (SURROUND Lch)、R35 (SURROUND Rch)、R36 (SURROUND BACK Rch)をカットし、電圧を再確認してください。
- 注意**
 パワーアンプ修理後に10.0 mV.を超えている場合は、抵抗をカットする前に故障箇所を調べてください。
- 60分後、電圧が0.2 mV~15.0 mV.であることを確認してください。

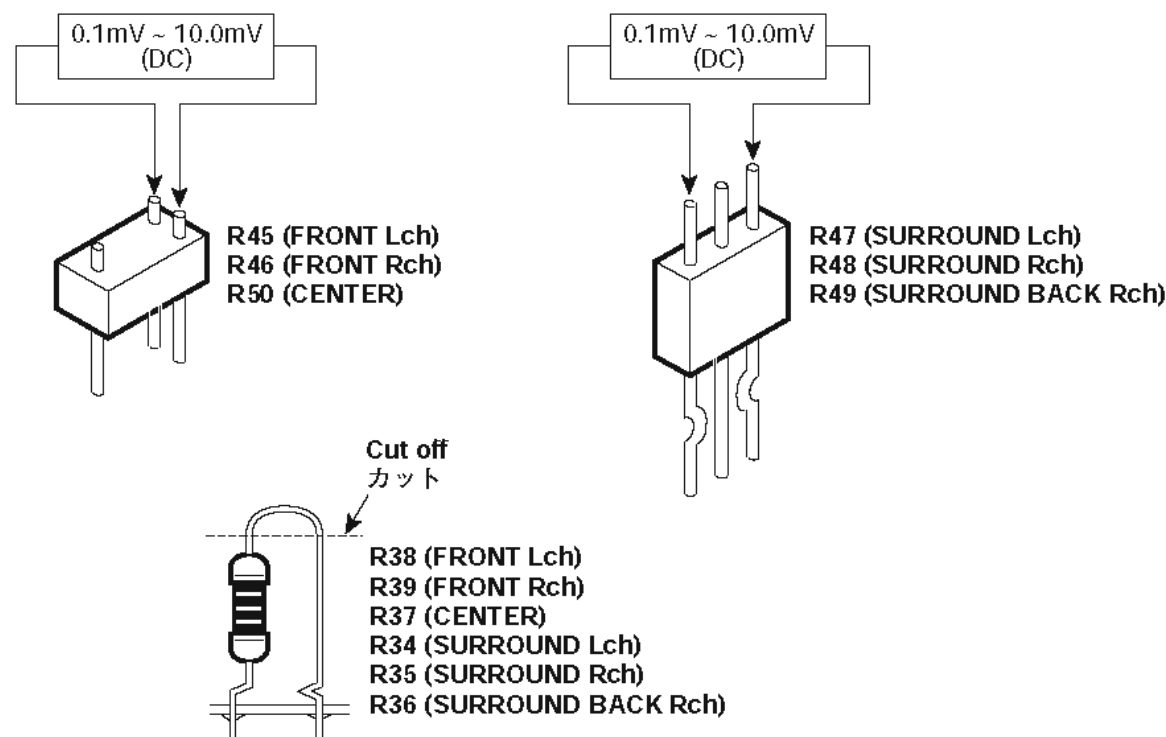

IC DATA

IC5 : D60YA003BPYP225 (DSP P.C.B.)
Decoder

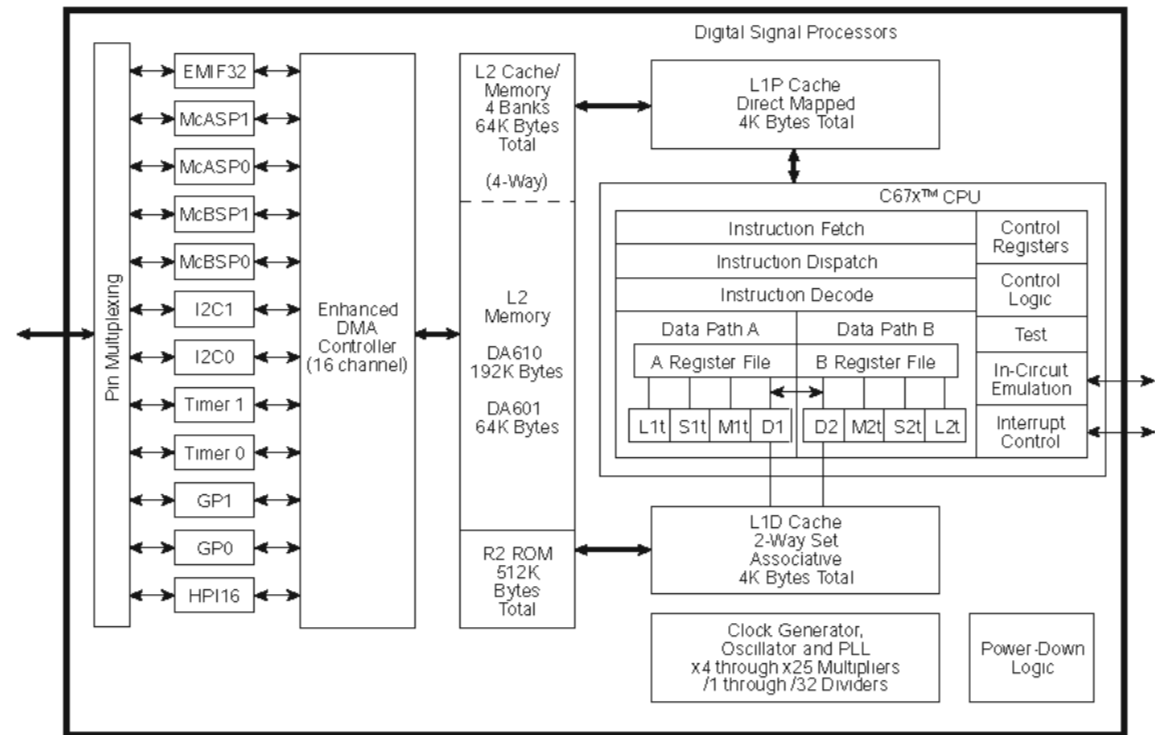

No.	Name [Default]	I/O	Function
1	GP0[4] / (EXT_INT4)	IOZ	General purpose I/O0 port 4 / Interrupt input (polarity selectable individually by using register)
2	GP0[6] / (EXT_INT6)	IOZ	General purpose I/O0 port 6 / Interrupt input (polarity selectable individually by using register)
3	CVDD	S	1.2V power supply
4	VSS	GND	Ground
5	DVDD	S	3.3V power supply
6	GP0[5] / (EXT_INT5)	IOZ	General purpose I/O0 port 5 / Interrupt input (polarity selectable individually by using register) (Unconnected)
7	GP0[7] / (EXT_INT7)	IOZ	General purpose I/O0 port 7 / Interrupt input (polarity selectable individually by using register) (Unconnected)
8	CLKS1	I	McBSP1 external clock source
9	DVDD	S	3.3V power supply
10	VSS	GND	Ground
11	CVDD	S	1.2V power supply
12	TINP1 / AHCLKX0	I / IOZ	Timer 1 Input / McASP0 Transmission MCLK
13	AXR1[11]	IOZ	McASP1 Transmission/reception data 11
14	CVDD	S	1.2V power supply
15	VSS	GND	Ground
16	CLKX0 / ACLKX0	IOZ	McBSP0 Transmission clock / McASP0 Transmission BCLK
17	AXR1[12]	IOZ	McASP1 Transmission/reception data 12
18	AXR1[13]	IOZ	McASP1 Transmission/reception data 13
19	ACLKR0	IOZ	McASP0 Reception BCLK
20	DX0	O/Z	McBSP0 Transmission data
21	FSX0	IOZ	McBSP0 Transmission Frame Sync
22	CVDD	S	1.2V power supply
23	VSS	GND	Ground
24	AFSR0	IOZ	McASP0 Reception LRCLK
25	DVDD	S	3.3V power supply
26	VSS	GND	Ground
27	DR0	I	McBSP0 Reception data
28	AHCLKR0	IOZ	McASP0 Reception MCLK
29	CVDD	S	1.2V power supply
30	VSS	GND	Ground
31	FSX1	IOZ	McBSP1 Transmission Frame Sync (Input in SPI slave state) (Unconnected)
32	AXR1[10]	IOZ	McASP1 Transmission/reception data 10
33	CLKX1 / AMUTE0	IOZ	McBSP1 Transmission clock (Input in SPI slave state) / McASP0 MUTE output (Unconnected)
34	VSS	GND	Ground
35	CVDD	S	1.2V power supply
36	AXR1[9]	IOZ	McASP1 Transmission/reception data 9
37	DR1 / SDA1	I / IOZ	McBSP1 Reception data / I2C1 data (Unconnected)
38	AXR1[8]	IOZ	McASP1 Transmission/reception data 8
39	VSS	GND	Ground
40	CVDD	S	1.2V power supply

IC5 : D60YA003BPYP225 (DSP P.C.B.)

Decoder

No.	Name	I/O	Function
41	SCL0	IOZ	I2C0 clock
42	SDA0	IOZ	I2C0 data
43	CVDD	S	1.2V power supply
44	DVDD	S	3.3V power supply
45	VSS	GND	Ground
46	CVDD	S	1.2V power supply
47	DVDD	S	3.3V power supply
48	VSS	GND	Ground
49	VSS	GND	Ground
50	CVDD	S	1.2V power supply
51	CVDD	S	1.2V power supply
52	VSS	GND	Ground
53	CVDD	S	1.2V power supply
54	VSS	GND	Ground
55	DVDD	S	3.3v power supply
56	ARDY	I	Asynchronous RAM Ready input
57	/CE3	O/Z	For external memory area, Enable 3 (Unconnected)
58	DVDD	S	3.3V power supply
59	VSS	GND	Ground
60	CVDD	S	1.2V power supply
61	/CE2	O/Z	For external memory area, Enable 2 (Unconnected)
62	EA2	O/Z	For external memory, Address 2
63	EA3	O/Z	For external memory, Address 3
64	EA4	O/Z	For external memory, Address 4
65	DVDD	S	3.3V power supply
66	VSS	GND	Ground
67	CVDD	S	1.2v power supply
68	EA5	O/Z	For external memory, Address 5
69	EA6	O/Z	For external memory, Address 6
70	EA7	O/Z	For external memory, Address 7
71	EA8	O/Z	For external memory, Address 8
72	DVDD	S	3.3V power supply
73	VSS	GND	Ground
74	EA9	O/Z	For external memory, Address 9
75	/SDRAS	O/Z	SDRAM RAS
76	EA10	O/Z	For external memory, Address 10
77	ECLKOUT	O/Z	Clock output for EMIF
78	ECLKIN	I	Clock input for EMIF (Unconnected)
79	/SDCAS	O/Z	SDRAM CAS
80	CVDD	S	1.2V power supply
81	VSS	GND	Ground
82	CLKOUT2 / GP0[2]	O/Z / IOZ	Half clock output of device Speed / General purpose I/O port 2 (Unconnected)
83	/SDWE	O/Z	SDRAM WE
84	DVDD	S	3.3V power supply
85	VSS	GND	Ground
86	EA11	O/Z	For external memory, Address 11
87	DVDD	S	3.3V power supply
88	VSS	GND	Ground
89	CVDD	S	1.2V power supply
90	EA14	O/Z	For external memory, Address 14 (Unconnected)
91	EA13	O/Z	For external memory, Address 13
92	EA16	O/Z	For external memory, Address 16 (Unconnected)
93	EA12	O/Z	For external memory, Address 12
94	EA15	O/Z	For external memory, Address 15 (Unconnected)
95	EA18	O/Z	For external memory, Address 18 (Unconnected)
96	CVDD	S	1.2V power supply
97	VSS	GND	Ground
98	DVDD	S	3.3V power supply

IC5 : D60YA003BPYP225 (DSP P.C.B.)

Decoder

No.	Name	I/O	Function
99	EA17	O/Z	For external memory, Address 17 (Unconnected)
100	EA19	O/Z	For external memory, Address 19 (Unconnected)
101	EA20	O/Z	For external memory, Address 20 (Unconnected)
102	/CE0	O/Z	For external memory area, Enable 0
103	/CE1	O/Z	For external memory area, Enable 1 (Unconnected)
104	CVDD	S	1.2V power supply
105	CVDD	S	1.2V power supply
106	VSS	GND	Ground
107	DVDD	S	3.3V power supply
108	/BE1	O/Z	For external memory, Byte Enable Control 1
109	EA21	O/Z	For external memory, Address 21 (Unconnected)
110	/BE0	O/Z	For external memory, Byte Enable Control 0
111	ED13	IOZ	For external memory, Data 13
112	ED15	IOZ	For external memory, Data 15
113	ED14	IOZ	For external memory, Data 14
114	DVDD	S	3.3V power supply
115	VSS	GND	Ground
116	CVDD	S	1.2V power supply
117	ED11	IOZ	For external memory, Data 11
118	ED12	IOZ	For external memory, Data 12
119	ED9	IOZ	For external memory, Data 9
120	ED10	IOZ	For external memory, Data 10
121	ED6	IOZ	For external memory, Data 6
122	ED7	IOZ	For external memory, Data 7
123	ED8	IOZ	For external memory, Data 8
124	CVDD	S	1.2V power supply
125	VSS	GND	Ground
126	DVDD	S	3.3V power supply
127	ED4	IOZ	For external memory, Data 4
128	ED5	IOZ	For external memory, Data 5
129	ED3	IOZ	For external memory, Data 3
130	ED2	IOZ	For external memory, Data 2
131	ED1	IOZ	For external memory, Data 1
132	ED0	IOZ	For external memory, Data 0
133	CVDD	S	1.2V power supply
134	VSS	GND	Ground
135	GP0[1]	IOZ	General purpose I/O port 1 (Unconnected)
136	BUSREQ	O/Z	For external memory, Bus request output (Unconnected)
137	/HOLDA	O/Z	For external memory, Hold request approval to host (Unconnected)
138	/HOLD	I	For external memory, Hold request from host
139	AFSR1	IOZ	McASP1 reception LRCLK
140	ACLKR1	IOZ	McASP1 reception BCLK
141	DVDD	S	3.3V power supply
142	VSS	GND	Ground
143	AXR[0]	IOZ	McASP1 transmission/reception data 0
144	AXR[1]	IOZ	McASP1 transmission/reception data 1
145	AXR1[2]	IOZ	McASP1 transmission/reception data 2
146	AXR18[3]	IOZ	McASP1 transmission/reception data 3
147	AXR1[4]	IOZ	McASP1 transmission/reception data 4
148	VSS	GND	Ground
149	CVDD	S	1.2V power supply
150	AXR1[5]	IOZ	McASP1 transmission/reception data 5
151	AXR1[6]	IOZ	McASP1 transmission/reception data 6
152	AXR1[7]	IOZ	McASP1 transmission/reception data 7
153	ACLKX1	IOZ	McASP1 transmission BCLK
154	AMUTE1	OZ	McASP1 MUTE output
155	AFSX1	IOZ	McASP1 transmission LRCLK
156	GP0[0]	IOZ	General purpose I/O port 0 (SPI ready signal output Active: H)

IC5 : D60YA003BPYP225 (DSP P.C.B.)

Decoder

No.	Name	I/O	Function
157	CVDD	S	1.2V power supply
158	VSS	GND	Ground
159	AHCLKX1	IOZ	McASP1 transmission MCLK
160	GP0[8]	IOZ	General purpose I/O0 port 8
161	AHCLKR1	IOZ	McASP1 reception MCLK
162	DVDD	S	3.3V power supply
163	VSS	GND	Ground
164	GP0[3]	IOZ	General purpose I/O0 port 3 (Unconnected)
165	GP0[9]	IOZ	General purpose I/O0 port 9
166	GP0[10]	IOZ	General purpose I/O0 port 10
167	GP0[11]	IOZ	General purpose I/O0 port 11
168	GP0[12]	IOZ	General purpose I/O0 port 12
169	CVDD	S	1.2V power supply
170	VSS	GND	Ground
171	CVDD	S	1.2V power supply
172	GP0[13]	IOZ	General purpose I/O0 port 13
173	GP0[14]	IOZ	General purpose I/O0 port 14
174	GP0[15]	IOZ	General purpose I/O0 port 15
175	NMI	I	Nonmaskable Interrupt ↑ edge
176	/RESET	I	Device reset
177	CVDD	S	1.2V power supply
178	OSCIN	I	X'tal input, Oscillation: 12 to 25MHz
179	OSCOU	O	X'tal output (Unconnected)
180	OSCVSS	GND	X'tal GND internal connection (Unconnected)
181	OSCVDD	S	X'tal 1.2V power supply internal connection (Unconnected)
182	VSS	GND	Ground
183	DVDD	S	3.3V power supply
184	CLKOUT3	O	Programmable clock output up to 32 division of PLL (Unconnected)
185	EMU1	IOZ	JTAG emulation pin 1 (1 k-ohms PD when boundary scanning)
186	EMU0	IOZ	JTAG emulation pin 0 (1 k-ohms PD when boundary scanning)
187	TDO	O/Z	JTAG Data Out
188	DVDD	S	3.3V power supply
189	VSS	GND	Ground
190	CVDD	S	1.2V power supply
191	TDI	I	JTAG Data In
192	TMS	I	JTAG Mode Select
193	TCK	I	JTAG Clock
194	VSS	GND	Ground
195	CVDD	S	1.2V power supply
196	CVDD	S	1.2V power supply
197	/TRST	I	JTAG Reset
198	RSV2	O/Z	Reserved (Unconnected)
199	PLLG	A	Analog GND for PLL
200	RSV0	A	Reserved (Unconnected)
201	PLLV	A	Analog 1.2V power supply for PLL
202	PLLVH	A	Analog 3.3V power supply for PLL
203	RSV1	I	Reserved (GND)
204	CLKIN	I	Clock input
205	CLKMODE0	I	PLL input clock selection: Clkin or X'tal
206	DVDD	S	3.3V power supply
207	VSS	GND	Ground
208	CVDD	S	1.2V power supply

RX-V557/HTR-5850/DSP-AX557
RX-V457/HTR-5840/DSP-AX457

IC451: M30626FHPFP (SUBTRANS P.C.B.)
16bit μ -COM (Main CPU)

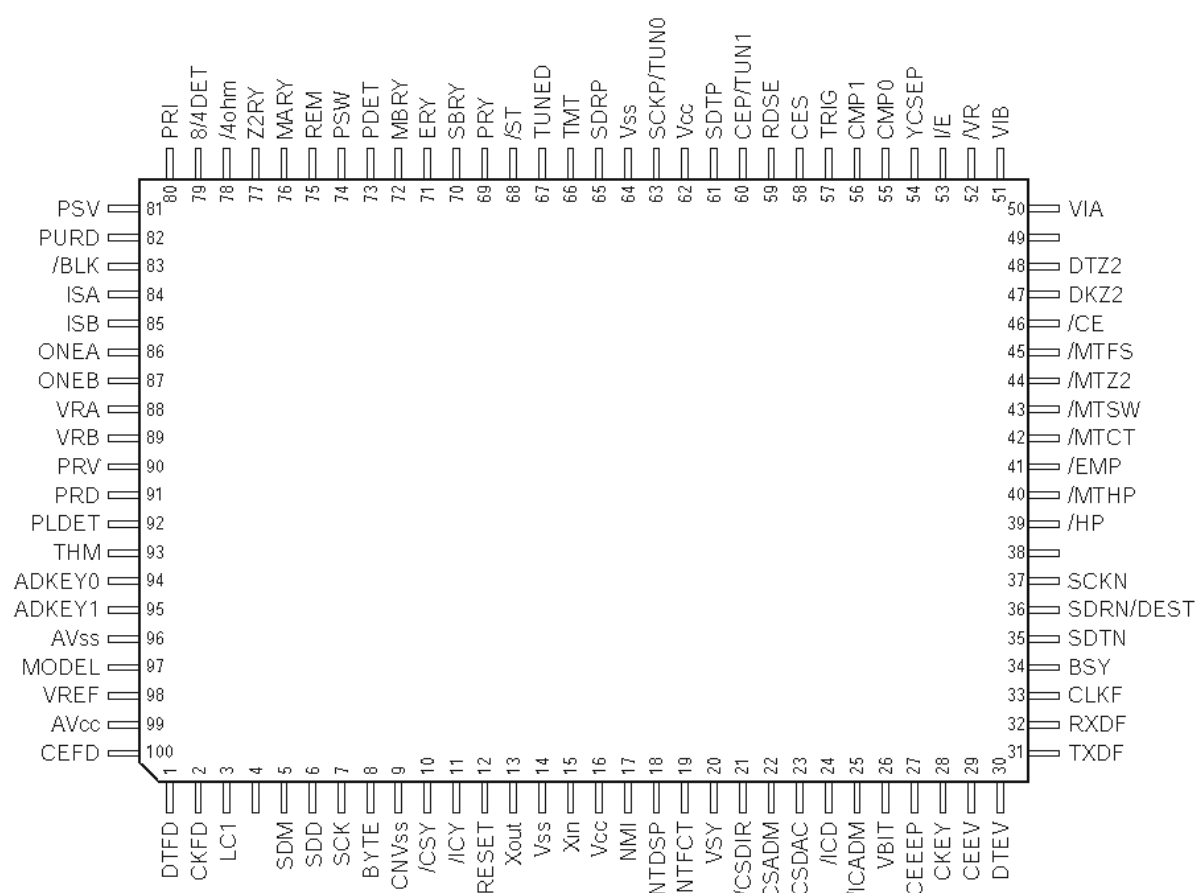

No.	Port Name	Terminal Name	I/O				Function
			PowerOn	Pure Direct	Standby	Sleep	
1	P96/ANEX1/SOUT4	DTFD	SO		O	O	FL Driver TxD
2	P95/ANEX0/CLK4	CKFD	SO		O	O	FL Driver CLOCK
3	P94/DA1/TB4in	LIMIT	DA		O	O	Limiter control output
4	P93/DA0/TB3in	TRIG	O		O	O	DC TRIGGER output
5	P92/TB2in/SOUT3	SDM	SO		O	O	Serial data output to DIR, TI (DA601) / DIR : 4M, LSBF/TI : 1M, MSBF
6	P91/TB1in/SIN3	SDD	SI		O	O	Serial data input from DIR, TI (DA601)
7	P90/TB0in/CLK3	SCK	SO		O	O	Serial data clock output to DIR, TI (DA601), DAC
8	BYTE	BYTE	MCU		MCU	MCU	Vss : When single chip mode is used
9	CNVss	CNVss	MCU		MCU	MCU	Vss : When single chip mode is used, Vcc : When flash writing is used
10	P87/Xcin	MUTETI	O		O	O	Muting (HI=MUTE) of TI decoder DSP DA601
11	P86/Xcout	TIBUSY	I		O	O	TI BUSY detection / CDDA write data input
12	/RESET	/RESET	MCU		MCU	MCU	Reset
13	Xout	Xout	MCU		MCU	MCU	Oscillation output (oscillation stopped in Sleep mode)
14	Vss	Vss	MCU		MCU	MCU	Ground for micro-processor
15	Xin	Xin	MCU		MCU	MCU	Oscillation input
16	Vcc1	Vcc	MCU		MCU	MCU	Power supply +5V for micro-processor
17	P85/NMI	NMI	MCU		MCU	MCU	Unused, connected to Vcc
18	P84/INT2	/INTTI	IRQ		O	O	Interruption of TI decoder DSP DA601
19	P83/INT1	/INTDIR	IRQ		O	O	Interruption of DIR
20	P82/INT0	N.C.	O		O	O	
21	P81/TA4in/U	/CSDIR	O		O	O	DIR chip enable
22	P80/TA4out/U	/CSTI	O		O	O	TI decoder DSP DA601 chip enable
23	P77/TA3in	/CSDAC	O		O	O	DAC (common to 2ch/8ch) chip enable
24	P76/TA3out	/ICDIR	O		O	O	DIR reset
25	P75/TA2in/W	/ICTI	O		O	O	TI decoder DSP DA601 reset
26	P74/TA2out/W	SPIRDY	O		O	O	TI DA601 Serial Ready / CDDA write WCK input
27	P73/CTS2/RTS2/TA1in/V	/CEEEP	I		O	O	EEPROM CE
28	P72/CLK2/TA1out/V	CKZ2	O		O	O	Zone2 Selector (BD3841) Clock (RX-V557_U, C, A, B, G, E models)
29	P71/RXD2/SCL2/TA0in/TB5in	DRXM	SI		O	O	DABIC IC RxD (U model)
30	P70/TXD2/SDA2/TA0out	DTXM	SO		O	O	DABIC IC TxD (U model)
31	P67/TXD1/SDA1	DTEV	SO		O	O	Electronic volume IC DATA
		TXDF	SO				Data transmission terminal for AF220

IC451: M30626FHFP (SUBTRANS P.C.B.)
16bit μ-COM (Main CPU)

No.	Port Name	Terminal Name	I/O			Function
			PowerOn	Pure Direct	Standby	
32	P66RXD1/SC14	DTZ2	0	0	0	Zone2 Selector (BD3841) DATA (RX-V557_U, C, A, B, G models)
33	P66CLK1	RXDF	SO	0	0	FLASH ROM RxD
34	P66CLK1	CKEV	SO	0	0	Electronic volume IC Clock
35	P66CLK1	CLKF	SO	0	0	Clock transmission terminal for AF220
36	P66CLK1	BSY	0	0	0	BUSY signal output for AF220
37	P66CLK1	DTCV	SO	0	0	IIC data I/O for video (RX-V557)
38	P66CLK1	CKCV	SO	0	0	IIC clock I/O for video (clock speed 100kHz) (RX-V557)
39	P66CLK1	H/P	1	0	0	HEAD PHONE detection
40	P66CLK1	MTHP	0	0	0	HEAD PHONE MUTE output
41	P66CLK1	MTCT	0	0	0	MUTE Center
42	P66CLK1	MTSW	0	0	0	MUTE SW
43	P66CLK1	EMP	1	0	0	For FLASH writing (LO)
44	P66CLK1	INTZ2	0	0	0	Zone 2 MUTE (RX-V557_U, C, A, B, G models)
45	P66CLK1	INTFS	0	0	0	MUTE Front/Surround, PreOUT
46	P66CLK1	VIA	0	0	0	VIDEO Selector A
47	P66CLK1	VIB	0	0	0	VIDEO Selector B
48	P66CLK1	VCE	1	0	0	For FLASH writing (HI)
49	P66CLK1	VR	0	0	0	VIDEO RecOut Selector 1
50	P66CLK1	YCSEP	0	0	0	Selection of Y/C separation (RX-V557)
51	P66CLK1	COMPOMOD3	0	0	0	Component Selector 0 (RX-V557, HTR-5850)
52	P66CLK1	CMP1	0	0	0	Component Selector 1 (RX-V557, HTR-5850)
53	P66CLK1	CPNTD	1	0	0	Component Signal Detector (DVD)
54	P66CLK1	CPNTT	1	0	0	Component Signal Detector (DTV)
55	P66CLK1	SVIDD	1	0	0	S-Video Signal Detector
56	P66CLK1	MOD2	1	0	0	MODEL distinction 2 (Data taken in when reset is cancelled)
57	P66CLK1	MOD1	1	0	0	MODEL distinction 1 (Data taken in when reset is cancelled)
58	P66CLK1	SDTN	0	0	0	RDS IC TXD (B, G models)
59	P66CLK1	SDRN	1	0	0	RDS RXD (B, G models)
60	P66CLK1	XMPWR	0	0	0	XM/DT BUS POWER CONTROL (U, C models)
61	P66CLK1	SCKN	0	0	0	RDS IC Clock (B, G models)
62	P66CLK1	I/CXM	0	0	0	DABIC IC reset (U model)
63	P66CLK1	RDSE	0	0	0	RDS Enable (B, G models)
64	P66CLK1	CEP	0	0	0	PLL IC Enable
65	P66CLK1	Voc	MCU	MCU	MCU	Power supply +5V for micro-processor
66	P66CLK1	SDTF	0	0	0	PLL IC TXD
67	P66CLK1	Vss	MCU	MCU	MCU	Ground for micro-processor
68	P66CLK1	SCKP	0	0	0	PLL IC Clock (With/without pull-up resistor is selected for every 4 bits)
69	P66CLK1	SDRP	1+	0	0	PLL IC RXD (With/without pull-up resistor is selected for every 4 bits)
70	P66CLK1	TUNED	1+	0	0	TUNED (With/without pull-up resistor is selected for every 4 bits)
71	P66CLK1	TUNED	1+	0	0	TUNED /ST (With/without pull-up resistor is selected for every 4 bits)
72	P66CLK1	TUNED	1+	0	0	TUNER MUTE
73	P66CLK1	PRY	0	0	0	Power relay output
74	P66CLK1	SBRV	0	0	0	Surround Back SP relay output
75	P66CLK1	ERY	0	0	0	Surround SP relay output
76	P66CLK1	PDET	0	0	0	Power Down DETECT INT
77	P66CLK1	IRQ	IRQ	IRQ	IRQ	SYSTEMMAIN/Zone2 Power switch interruption (Pushed switch is judged using ADKEY0 and ADKEY1. Refer to Details of "AD-DA".)
78	P66CLK1	REM	0	0	0	Remote control input
79	P66CLK1	MBRY	0	0	0	Front B SP relay output
80	P66CLK1	MARY	0	0	0	Front A SP relay output
81	P66CLK1	YST	0	0	0	YST amp control (HTR-5835)
82	P66CLK1	4ohm	0	0	0	IMPEDANCE control: At 8ohm setting, Low (relay OFF, B voltage High) / ±B voltage Control: At 4ohm setting and temperature rise, High (relay ON, B voltage Low)
83	P66CLK1	PRI	1	0	0	Protection over current detection
84	P66CLK1	PSV	0	0	0	Power Save
85	P66CLK1	VMUTE	0	0	0	VIDEO MUTE control (Low: VIDEO MUTE ON) (RX-V557)
86	P66CLK1	BLK	0	0	0	FL Driver light off

IC451: M30626FHFP (SUBTRANS P.C.B.)
16bit μ-COM (Main CPU)

No.	Port Name	Terminal Name	I/O			Function
			PowerOn	Pure Direct	Standby	
84	P04/D4	ISA	1	0	0	INPUT Selector Rotary A
85	P03/D3	ISB	1	0	0	INPUT Selector Rotary B
86	P02/D2	TONEA	0	0	0	Tone Control Rotary A (RX-V557, DSP-AX557)
87	P01/D1	TOWEB	1	0	0	Tone Control Rotary B (RX-V557, DSP-AX557)
88	P00/D0	VRB	1	0	0	Volume Rotary A
89	P107/ANT/K13	VRB	1	0	0	Volume Rotary B
90	P106/AN6/K12	PRV	AD	AD	AD	AD protection power supply voltage detection (Refer to Protection Setting Table.)
91	P106/AN5/K11	PRD	AD	AD	AD	AD protection DC detection (Refer to Protection Setting Table.)
92	P104/AN4/K10	PLDET	AD	AD	AD	AD POWER LIMITER detection (Refer to Limiter Setting Table.)
93	P103/AN3	THM	AD	AD	AD	AD temperature detection (Refer to Protection Setting Table.)
94	P102/AN2	ADKEY0	AD	AD	AD	AD Key 0 (Refer to Details of "AD-DA".)
95	P101/AN1	ADKEY1	AD	AD	AD	AD Key 1 (Refer to Details of "AD-DA".)
96	A/SS	A/SS	MCU	MCU	MCU	Ground for AD
97	P100/AN0	DEST	AD	AD	AD	Distinction for AD (Data taken in when reset is cancelled. Refer to Details of "AD-DA".)
98	Vref	Vref	MCU	MCU	MCU	Reference for AD
99	A/CC	A/CC	MCU	MCU	MCU	Power supply for AD
100	P97/Adtg/Sin4	CEFD / MOD0	0	0 / 1	0	FL Driver CE / MODEL distinction 0 (Data taken in when reset is cancelled.)

RX-V557 (U, C, A, B, G, E models)
Key Input(A-D) Pull-Up Resistance 10 k-Ohms

Ohm	+0.0 k	+1.0 k	+1.0 k	+1.5 k	+2.2 k	+3.3 k	+4.7 k	+4.7 k	+6.8 k	+10.0 k	+22.0 k
V	~0.3	~0.7	~1.0	1.5	~2.0	~2.6	~3.1	~3.4	~3.7	~4.0	~4.4
ADKEY0	MAIN POWER	-	-	-	INPUT MODE	STRAIGHT	TONE CONTROL	PRESET/TUNING	SPEAKER	SPEAKER	-
ADKEY1	Z2 POWER	-	-	-	MULTI CH	F/M/A/M	AB/C/D/E	PRESET/TUNING	PRESET/TUNING	MEMORY	TUNING MODE
ADKEY1	-	-	-	-	INPUT	F/M/A/M	AB/C/D/E	<	>	MEMORY	TUNING MODE

RX-V557/DSP-AX557 (R, T, K, L, J models)
Key Input(A-D) Pull-Up Resistance 10 k-Ohms

Ohm	+0.0 k	+1.0 k	+1.0 k	+1.5 k	+2.2 k	+3.3 k	+4.7 k	+4.7 k	+6.8 k	+10.0 k	+22.0 k
V	~0.3	~0.7	~1.0	1.5	~2.0	~2.6	~3.1	~3.4	~3.7	~4.0	~4.4
ADKEY0	PROGRAM	PROGRAM	BASS/TREBLE	BASS/TREBLE	INPUT MODE	STRAIGHT	TONE CONTROL	PRESET/TUNING	SPEAKER	SPEAKER	-
ADKEY1	-	-	-	-	MULTI CH	F/M/A/M	AB/C/D/E	PRESET/TUNING	PRESET/TUNING	MEMORY	TUNING MODE
ADKEY1	-	-	-	-	INPUT	F/M/A/M	AB/C/D/E	<	>	MEMORY	TUNING MODE

RX-V457/HTR-5840 (B, G, E models)
Key Input(A-D) Pull-Up Resistance 10 k-Ohms

Ohm	+0.0 k	+1.0 k	+1.0 k	+1.5 k	+2.2 k	+3.3 k	+4.7 k	+4.7 k	+6.8 k	+10.0 k	+22.0 k
V	~0.3	~0.7	~1.0	1.5	~2.0	~2.6	~3.1	~3.4	~3.7	~4.0	~4.4
ADKEY0	PROGRAM	PROGRAM	BASS/TREBLE	BASS/TREBLE	INPUT MODE	STRAIGHT	TONE CONTROL	PRESET/TUNING	SPEAKER	SPEAKER	-
ADKEY1	EON	MODE	PTY SEEK	PTY SEEK	MULTI CH	F/M/A/M	AB/C/D/E	PRESET/TUNING	PRESET/TUNING	MEMORY	TUNING MODE
ADKEY1	-	-	-	-	INPUT	F/M/A/M	AB/C/D/E	<	>	MEMORY	TUNING MODE

MODEL Distinction Port / 端子判別ポート
Pull-Up Resistance 10 k-Ohms

Pin	Function	Name	RX-V557/DSP-AX557	HTR-5850	RX-V457/HTR-5840/DSP-AX457
100	P97	MOD0	0	1	1
56	P36	MOD1	0	0	1
55	P37	MOD2	1	1	1
50	P44	MOD3	-	-	-

BLOCK DIAGRAM (1/2)

RX-V557/HTR-5850/DSP-AX557

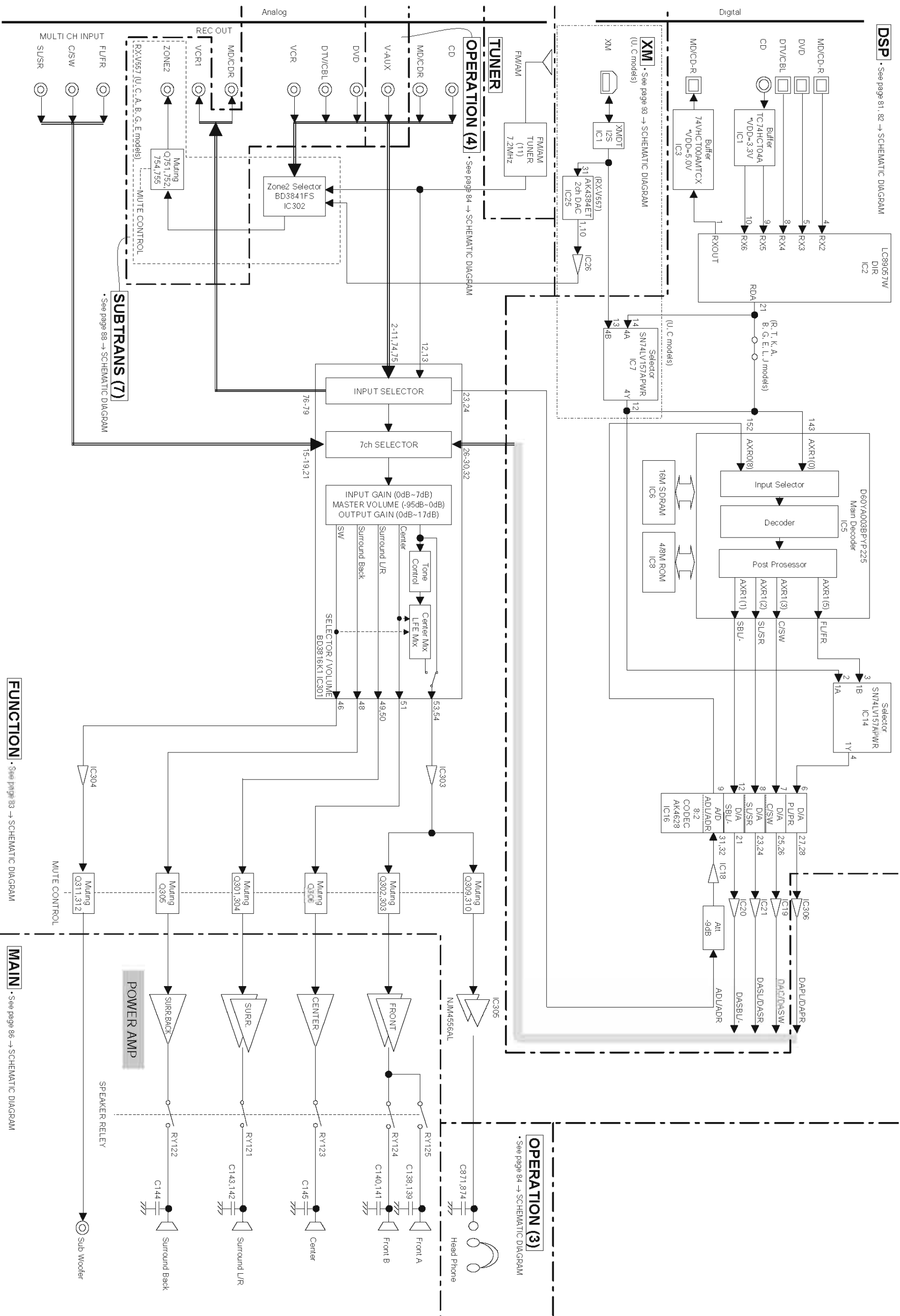

1 BLOCK DIAGRAM (2/2) RX-V557/HTR-5850/DSP-AX557

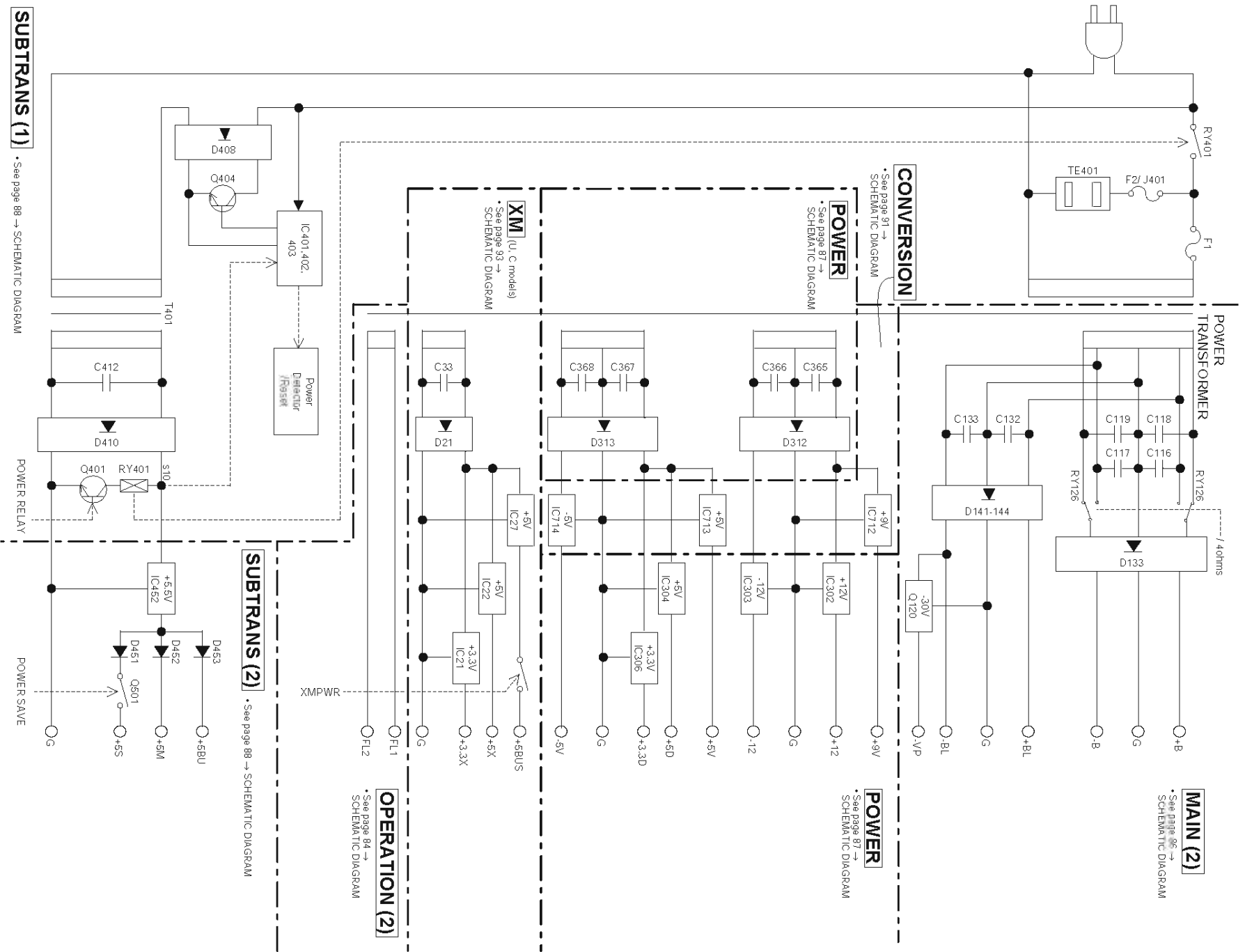
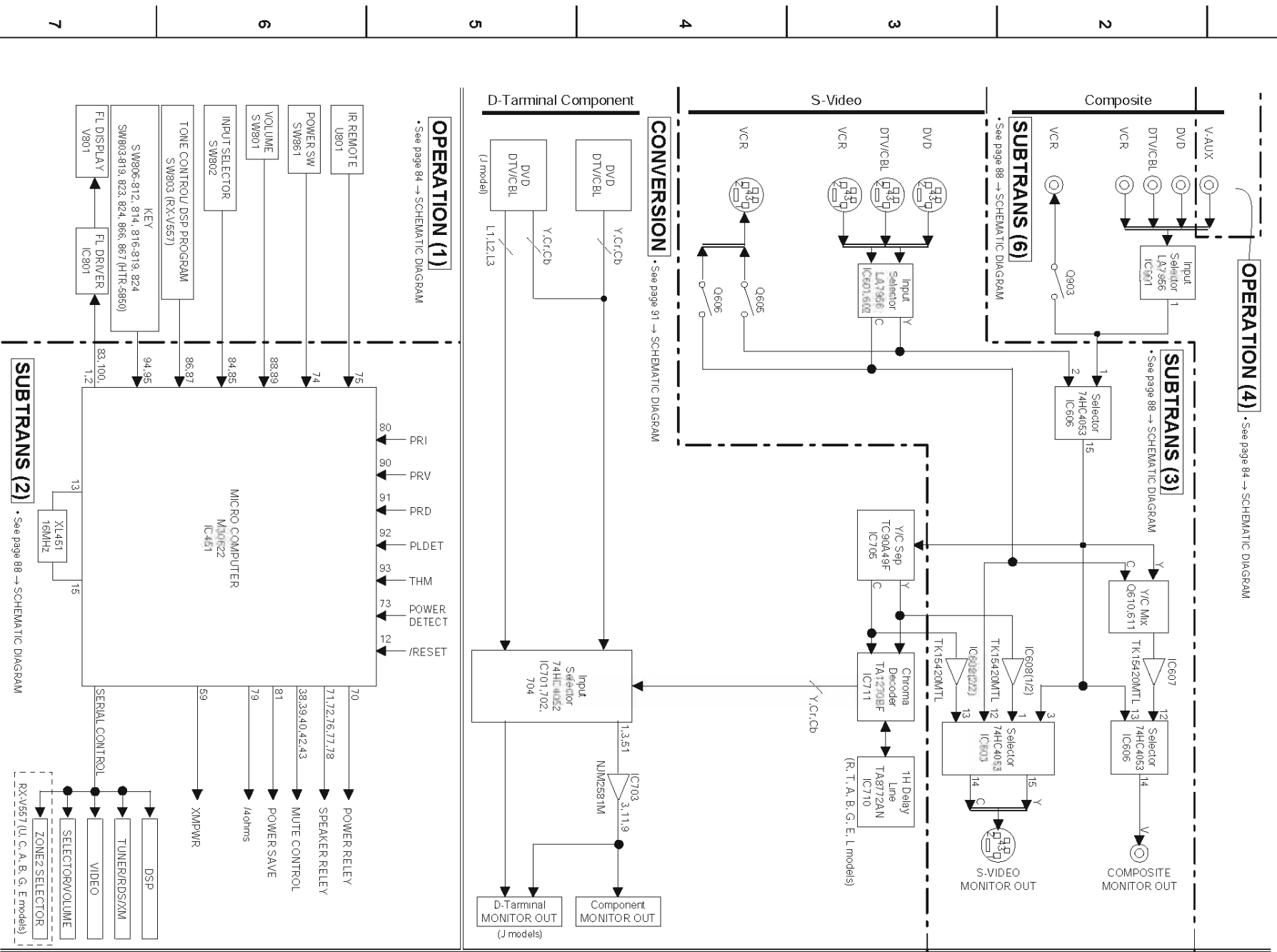

BLOCK DIAGRAM (1/2)

RX-V457/HTR-5840/DSP-AX457

DSP • See page 91, 92 → SCHEMATIC DIAGRAM

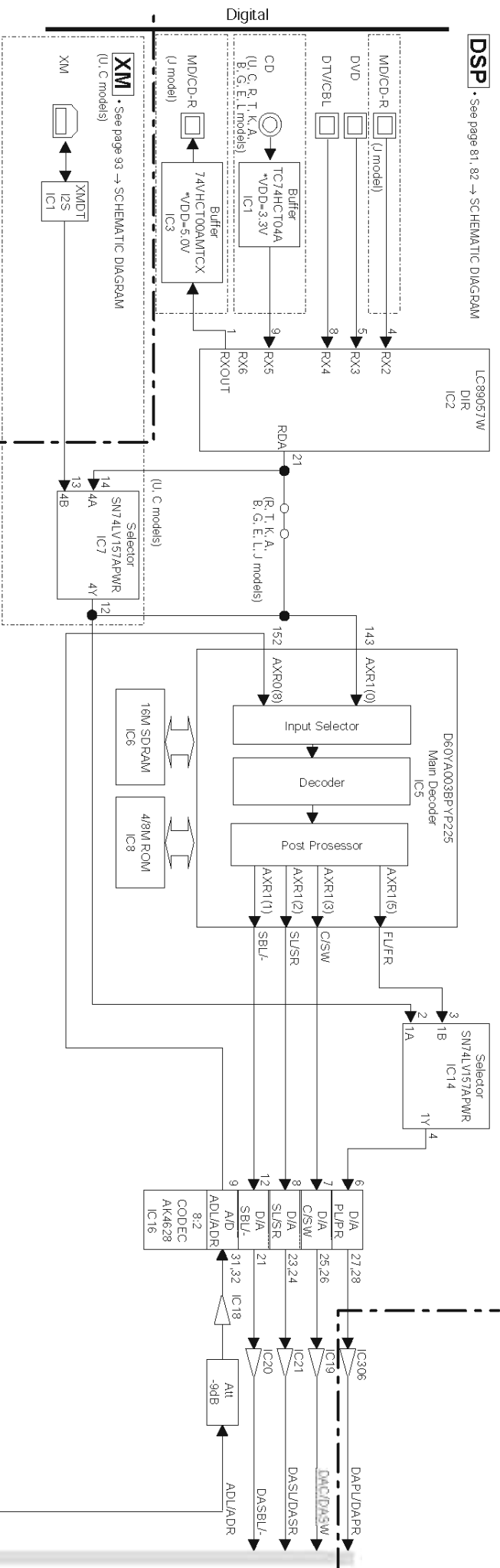

OPERATION (3)

• See page 85 → SCHEMATIC DIAGRAM

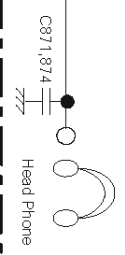

TUNER

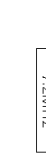

OPERATION (4)

• See page 85 → SCHEMATIC DIAGRAM

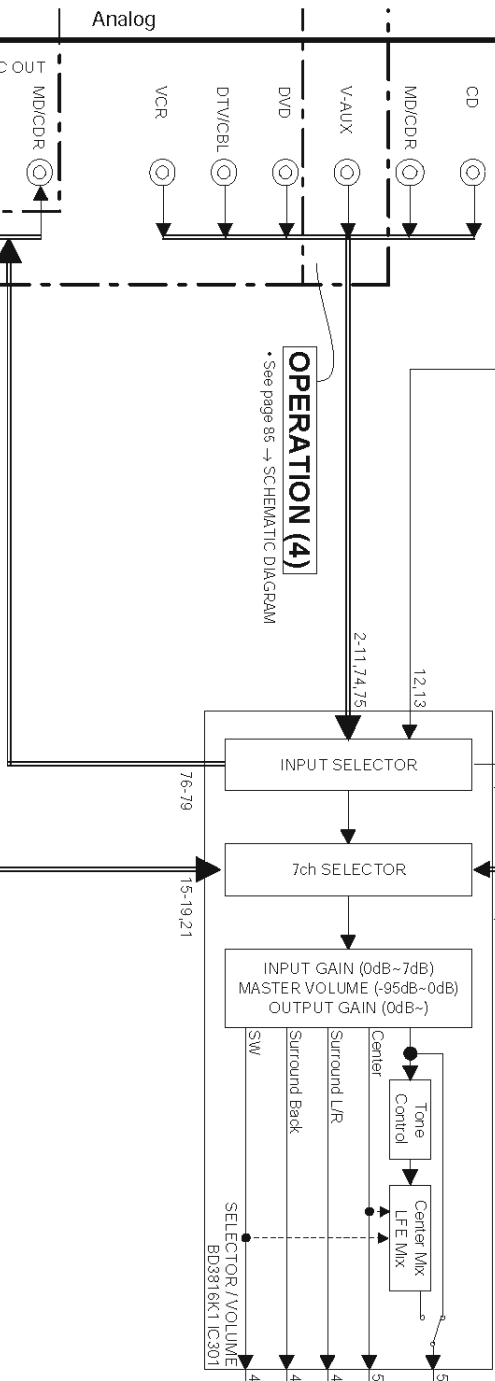

SUBTRANS (7)

• See page 90 → SCHEMATIC DIAGRAM

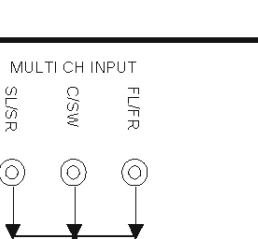

FUNCTION

• See page 83 → SCHEMATIC DIAGRAM

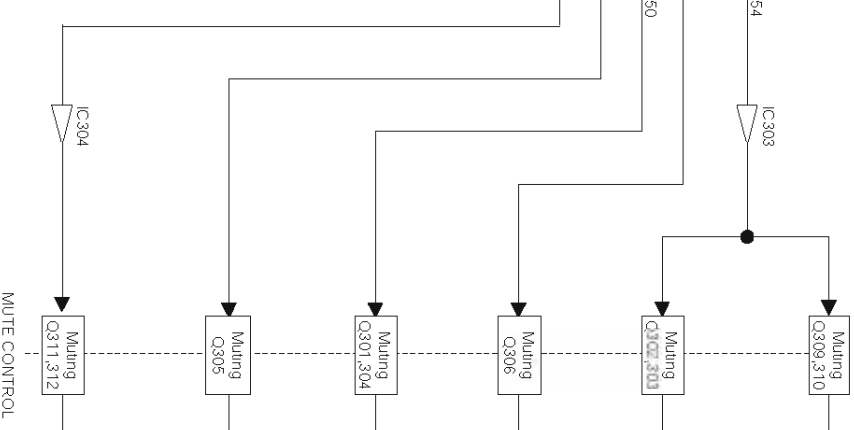

MAIN

• See page 86 → SCHEMATIC DIAGRAM

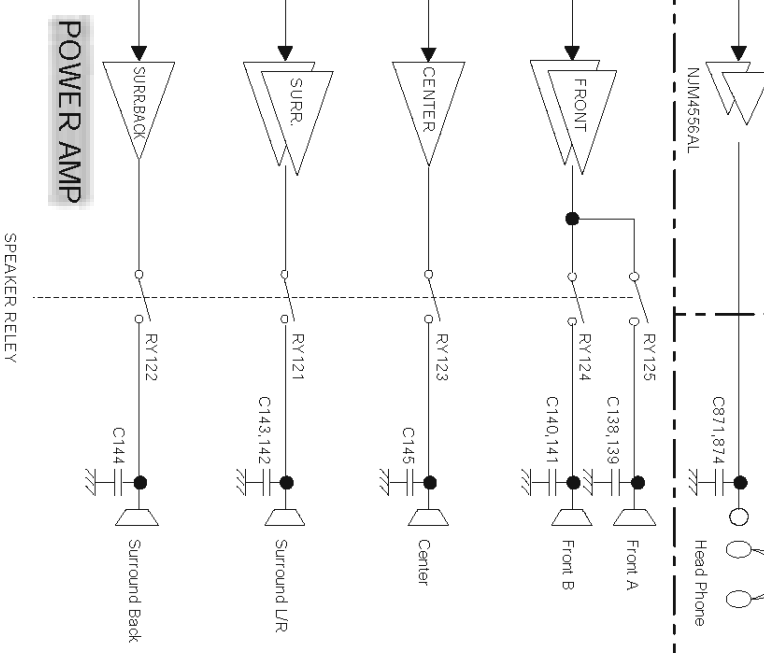

1 ■ BLOCK DIAGRAM (2/2) [RX-V457/HTR-5840/DSP-AX457]

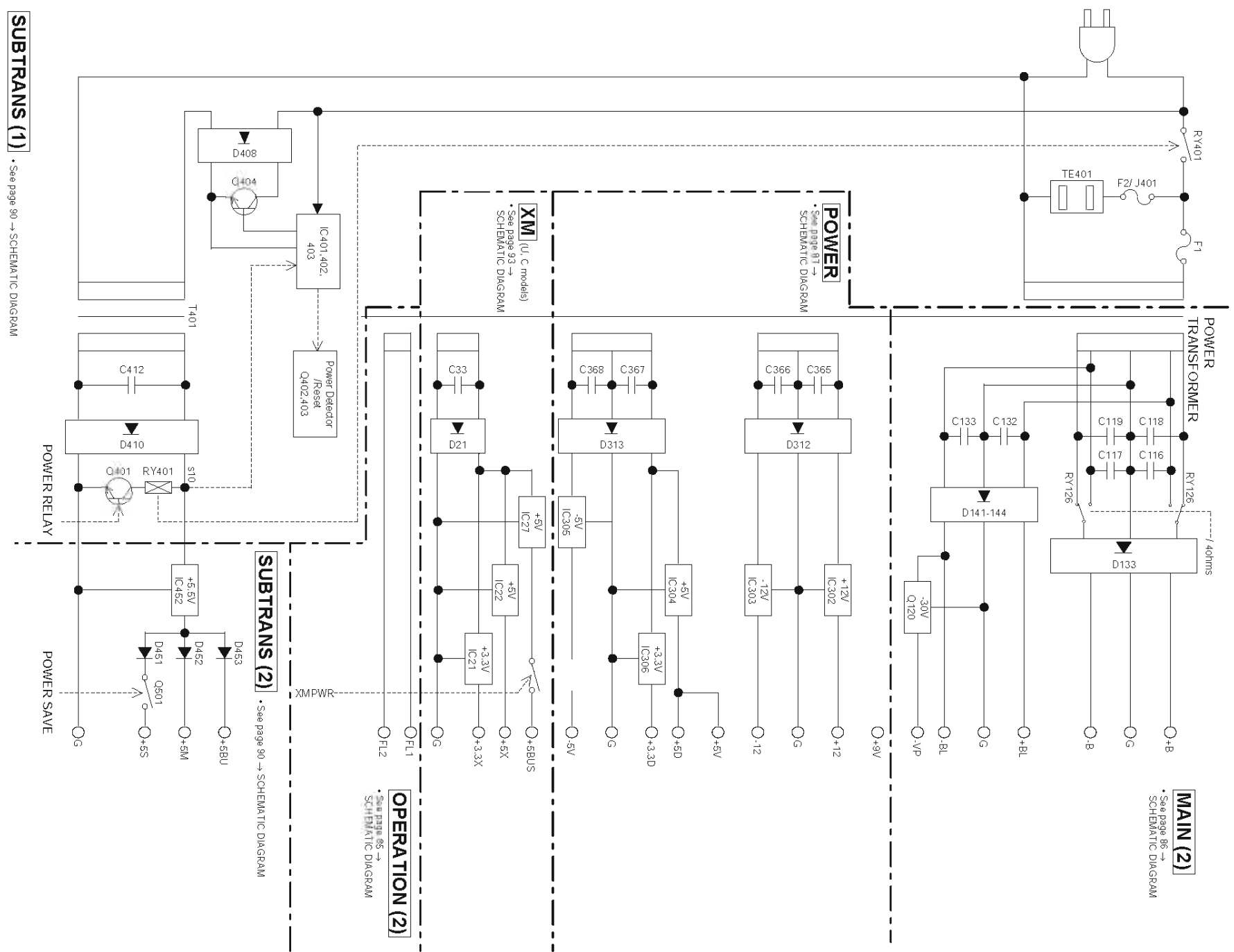
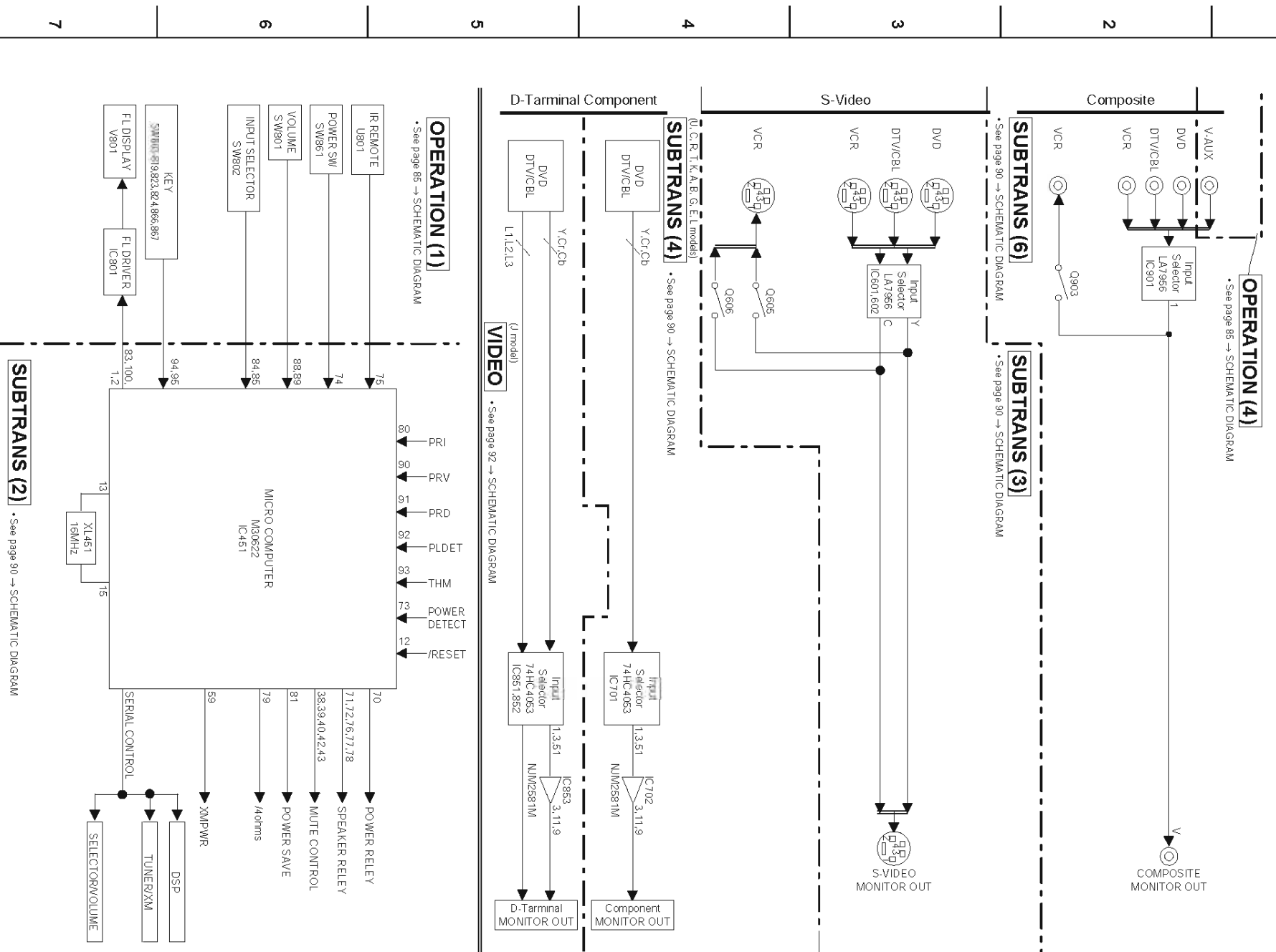

■ DISPLAY DATA

● V801 : 17-BT-24GNK (WE289300)

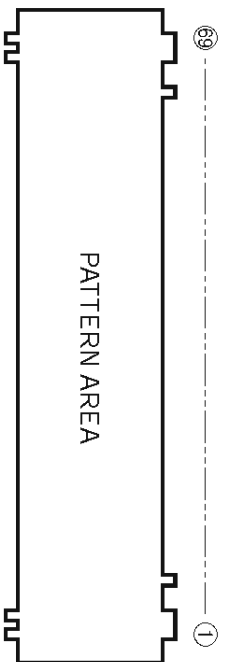

● PIN CONNECTION

Pin No.	69	68	67	66	65	64	63	62	61	60	59	58	57	56	55	54	53	52	51	50	49	48	47	46	45	44	43	42	41	40	39	38	37	36	35
Connection	F2	NX	NP	NP	P1	P2	P3	P4	P5	P6	P7	P8	P9	P10	P11	P12	P13	P14	P15	P16	P17	P18	P19	P20	P21	P22	P23	P24	P25	P26	P27	P28	P29	P30	P31
Pin No.	34	33	32	31	30	29	28	27	26	25	24	23	22	21	20	19	18	17	16	15	14	13	12	11	10	9	8	7	6	5	4	3	2	1	
Connection	P32	P33	P34	P35	P36	P37	NX	NX	NX	NX	NX	NX	NX	NX	17G	16G	15G	14G	13G	12G	11G	10G	9G	8G	7G	6G	5G	4G	3G	2G	1G	NP	NX	F1	

Note : 1) F1, F2 Filament 2) NP No pin 3) NX No external pin 4) DL Datum line 5) 1G ~ 16G Grid

● GRID ASSIGNMENT

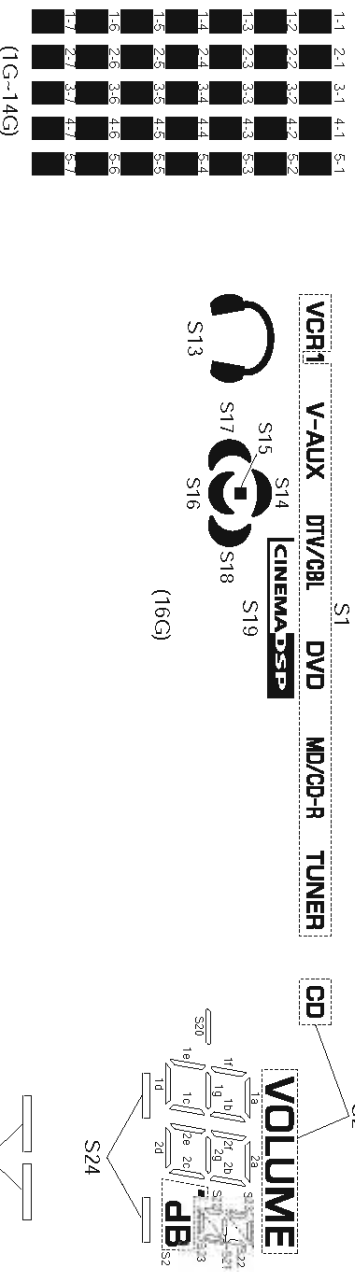
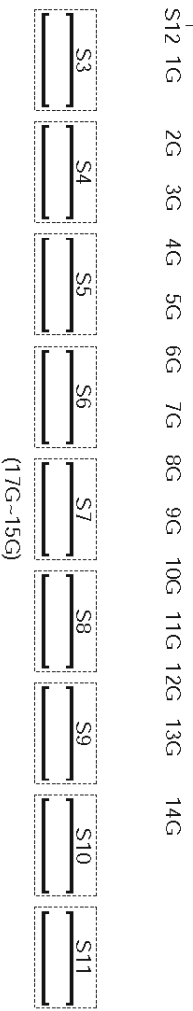
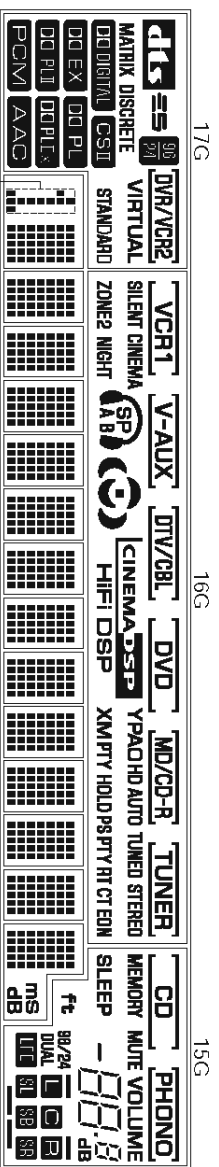

● ANODE CONNECTION

Pin	17G	16G	15G	14G	13G-2G	1G
P1	DTS	EDM	SLEEP	1-1	1-1	1-1
P2	ES	GT	MEMORY	2-1	2-1	2-1
P3	MATRIX	RT	MUTE	3-1	3-1	3-1
P4	DISCRETE	PTY	S20	4-1	4-1	4-1
P5	DS	PS	1a	5-1	5-1	5-1
P6	DD DIGITAL	PTY HOLD	1b	1-2	1-2	1-2
P7	DD EX	XM	1c	2-2	2-2	2-2
P8	DD PL	S14	1d	3-2	3-2	3-2
P9	DD FILE	S15	1e	4-2	4-2	4-2
P10	DD PLS	S16	1f	5-2	5-2	5-2
P11	AAC	S17	1g	1-3	1-3	1-3
P12	PCM	S18	2a	2-3	2-3	2-3
P13	STANDARD	SILENT CINEMA	2b	3-3	3-3	3-3
P14	CSI	S13	2c	4-3	4-3	4-3
P15	VIRTUAL	SP	2d	5-3	5-3	5-3
P16	DVR/VCR2	A	2e	1-4	1-4	1-4
P17	S3	B	2f	2-4	2-4	2-4
P18	-	ZONE2	2g	3-4	3-4	3-4
P19	-	NIGHT	S2	4-4	4-4	4-4
P20	-	HIFI DSP	S10	5-4	5-4	5-4
P21	-	S19	S11	1-5	1-5	1-5
P22	-	YPAO	PHONO	2-5	2-5	2-5
P23	-	HD	S21	3-5	3-5	3-5
P24	-	AUTO	S22	4-5	4-5	4-5
P25	-	TUNED	S23	5-5	5-5	5-5
P26	-	STEREO	ft	1-6	1-6	1-6
P27	-	S4	S24	2-6	2-6	2-6
P28	-	S5	80/24	3-6	3-6	3-6
P29	-	S6	DUAL	4-6	4-6	4-6
P30	-	S7	LFE	5-6	5-6	5-6
P31	-	S8	L	1-7	1-7	1-7
P32	-	S9	C	2-7	2-7	2-7
P33	-	I	B	3-7	3-7	3-7
P34	-	S1	R	4-7	4-7	4-7
P35	-	-	S0	5-7	5-7	5-7
P36	-	-	S0	ms	-	S12
P37	-	-	S25	dB	-	-

PRINTED CIRCUIT BOARD (Foil side)

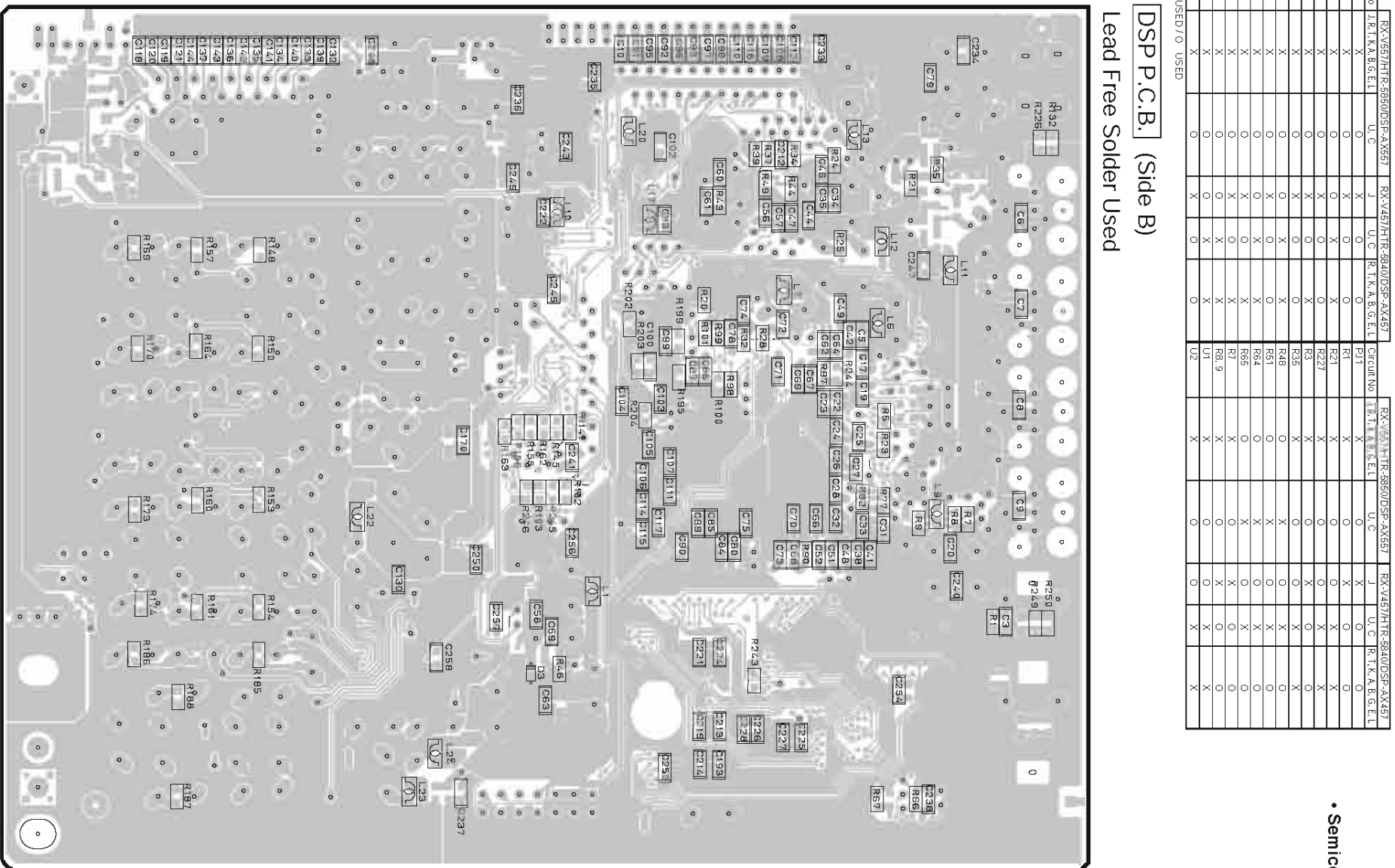
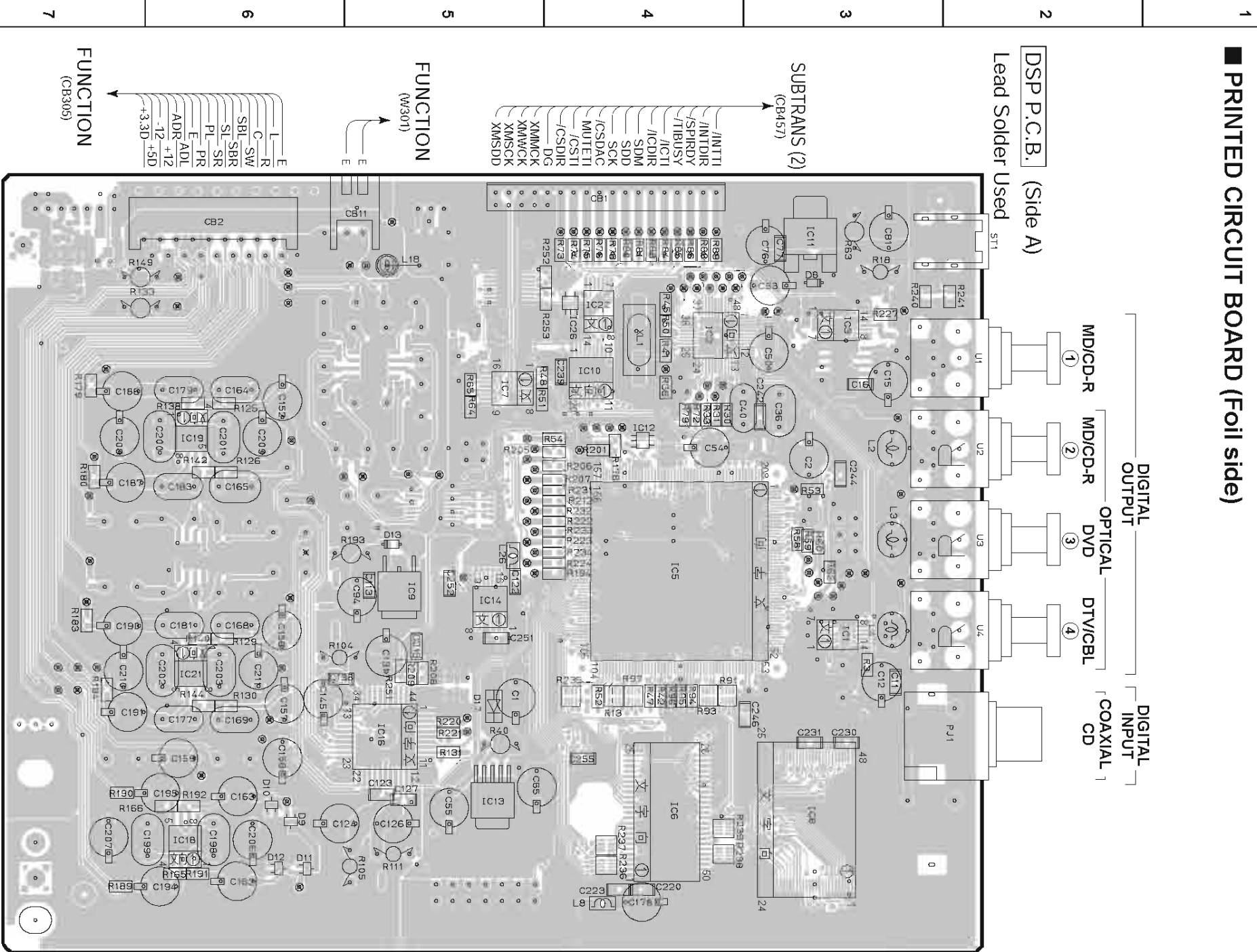

Circuit No.	J.R.T.A. 8.G.E.L.L	U.C	J	U.C	R.T.K.A. 8.G.E.L.L	U.C	R.T.K.A. 8.G.E.L.L	J	U.C	R.T.K.A. 8.G.E.L.L	U.C	R.T.K.A. 8.G.E.L.L
CB11	X		X									
CB12	X		X									
CB16	X		X									
CB20	X		X									
CB222	X		X									
CB3	X		X									
CB6.7	X		X									
CB31	X		X									
CB3	X		X									
CB7	X		X									
CB3	X		X									
CB10	X		X									
CB11	X		X									
CB2	X		X									
CB9	X		X									

DSP P.C.B. (Side A)
Lead Solder Used

DSP P.C.B. (Side B)
Lead Free Solder Used

- DSP P.C.B. (Side A)
Lead Solder Used
- DSP P.C.B. (Side B)
Lead Free Solder Used
- Digital Output
- Digital Input
- Optical DVD
- DTV/CBL
- Coaxial CD

• Semiconductor Location

Ref. No.	Location
D3	I5
D8	B3
D9	E6
D10	E6
D11	E6
D12	E6
D13	C5
IC1	D3
IC2	B4
IC3	B3
IC4	C4
IC5	C4
IC6	E4
IC7	B5
IC8	E3
IC9	C5
IC10	B4
IC11	B3
IC12	C4
IC13	E5
IC14	D5
IC16	D5
IC18	E6
IC19	C6
IC21	D6
IC22	B4
IC26	B4

PRINTED CIRCUIT BOARD (Foil side)

FUNCTION P.C.B. (Side A)

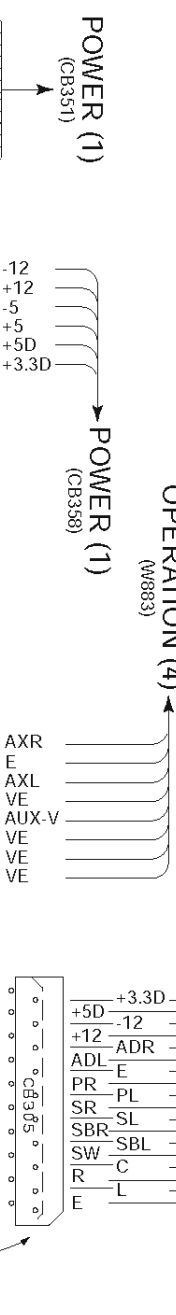

• Semiconductor Location

Ref. No.	Location
D303	B4
D304	C5
IC305	B5
Q307	D5
Q308	E5

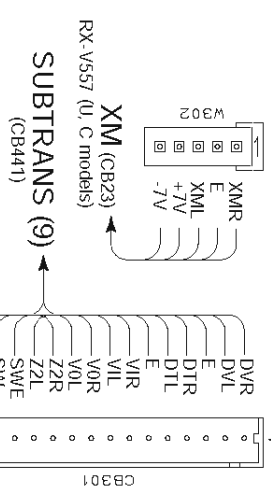
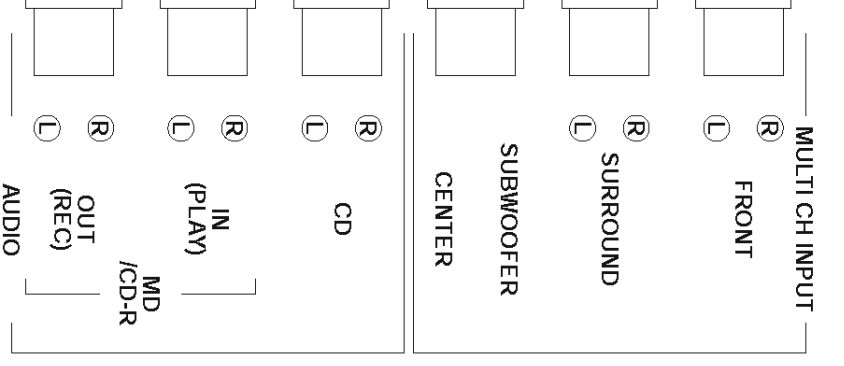
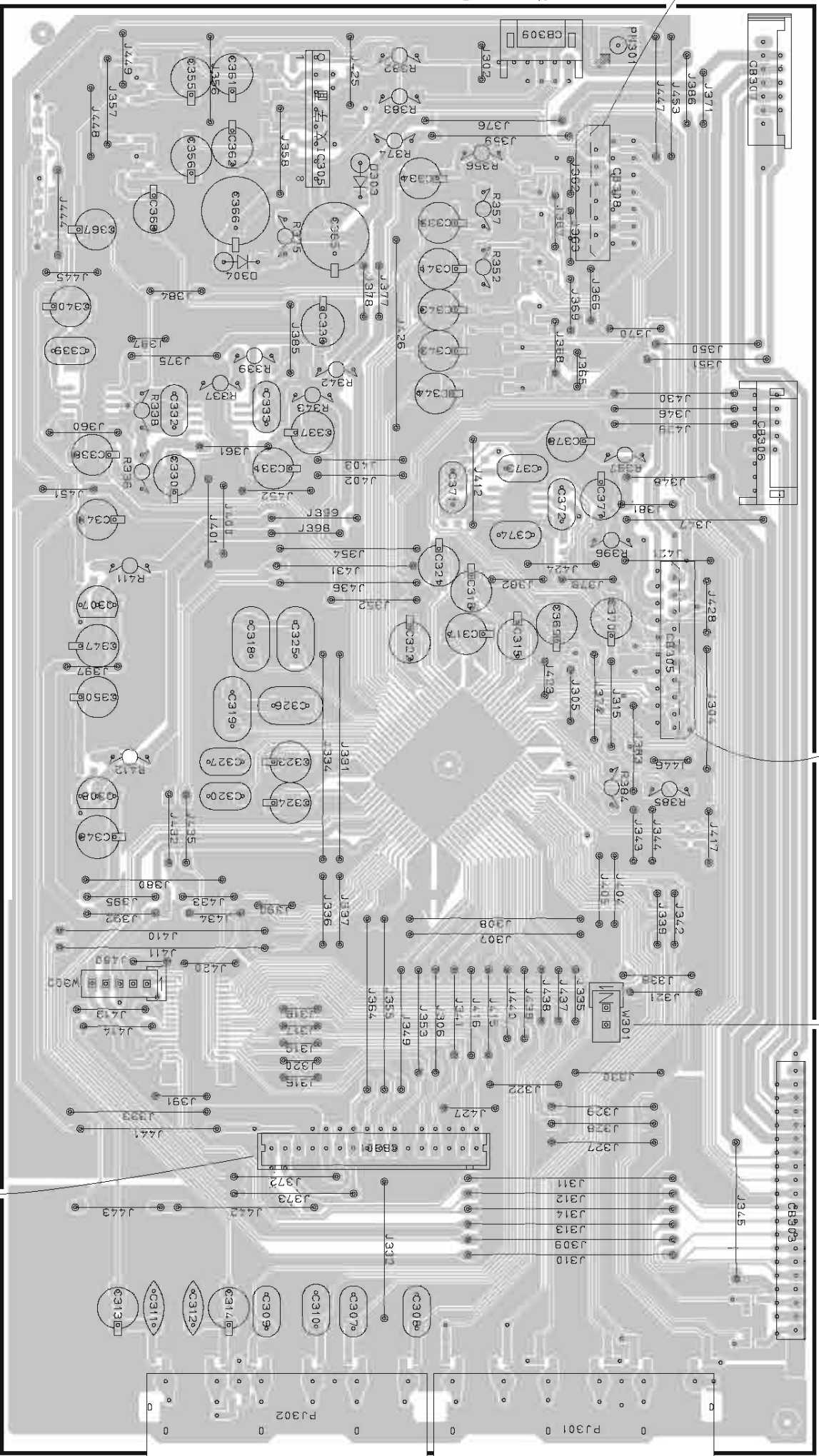
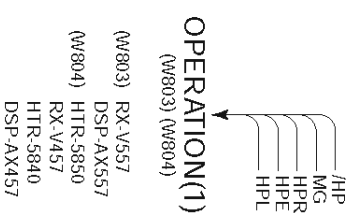

RX-V557/DSP-AX557		J.R.T.K.L. U. C.A.R.G.E	
Direct No.		X	O
C328-329		X	O
IC202		X	O
W302		X	O
HTR-5850/HTR-V457/HTR-5840/DSP-AX457		J.U.C.R.T.K.A.B.G.E.L	
Direct No.		X	X
C328-329		X	X
IC302		X	X
W302		X	X

X NOT USED / O USED

1 ■ PRINTED CIRCUIT BOARD (Foil side)

FUNCTION P.C.B. (Side B) Lead Free Solder Used

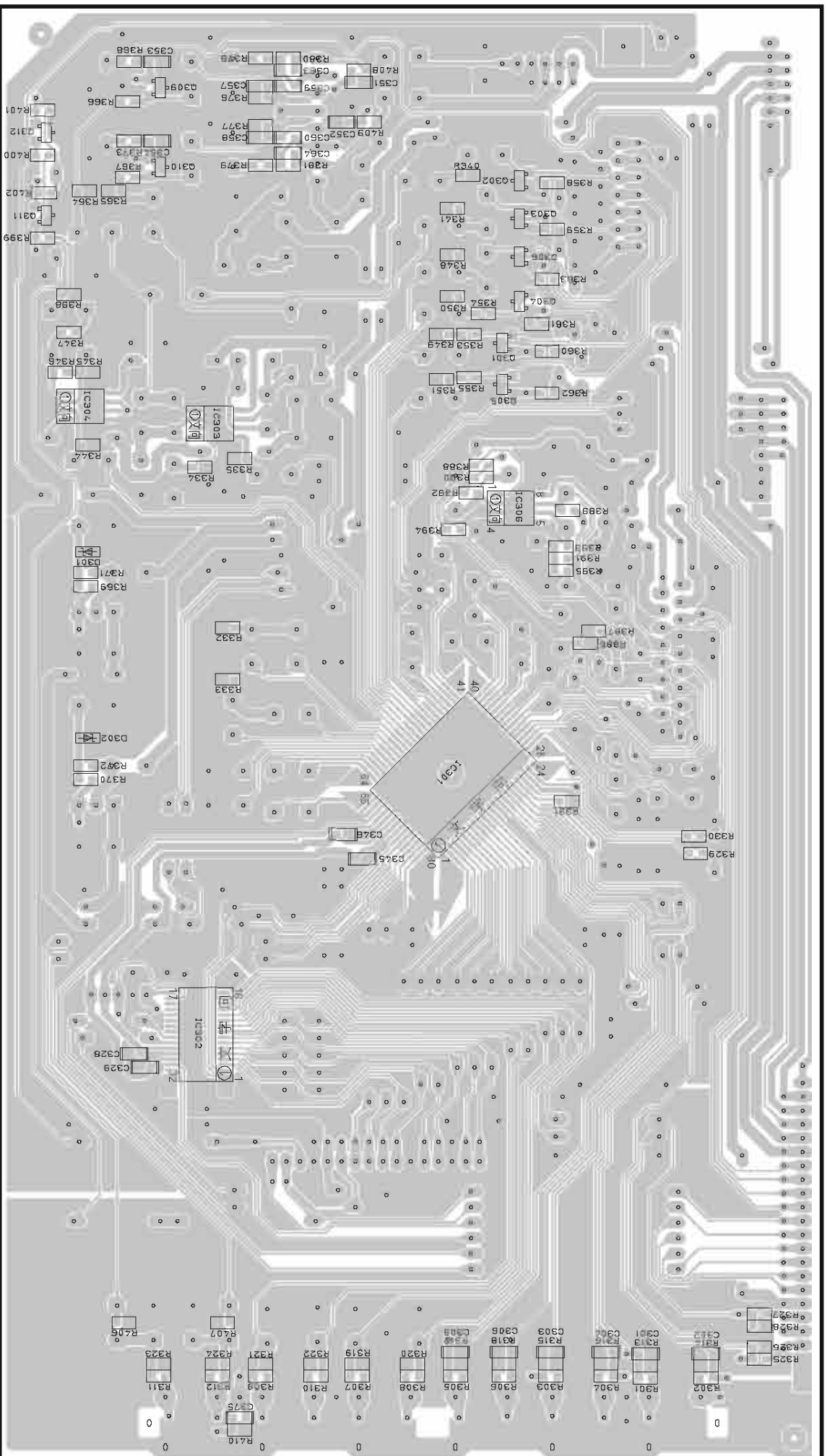

• Semiconductor Location

Ref. No.	Location
D301	D6
D302	E6
IC301	E4
IC302	F5
IC303	C5
IC304	C6
IC306	D4
Q301	C4
Q302	B4
Q303	B4
Q304	C4
Q305	C4
Q309	B5
Q310	B5
Q311	B6
Q312	B6

PRINTED CIRCUIT BOARD (Foil side) RX-V557/DSP-AX557

OPERATION (1) P.C.B.

(Side A)

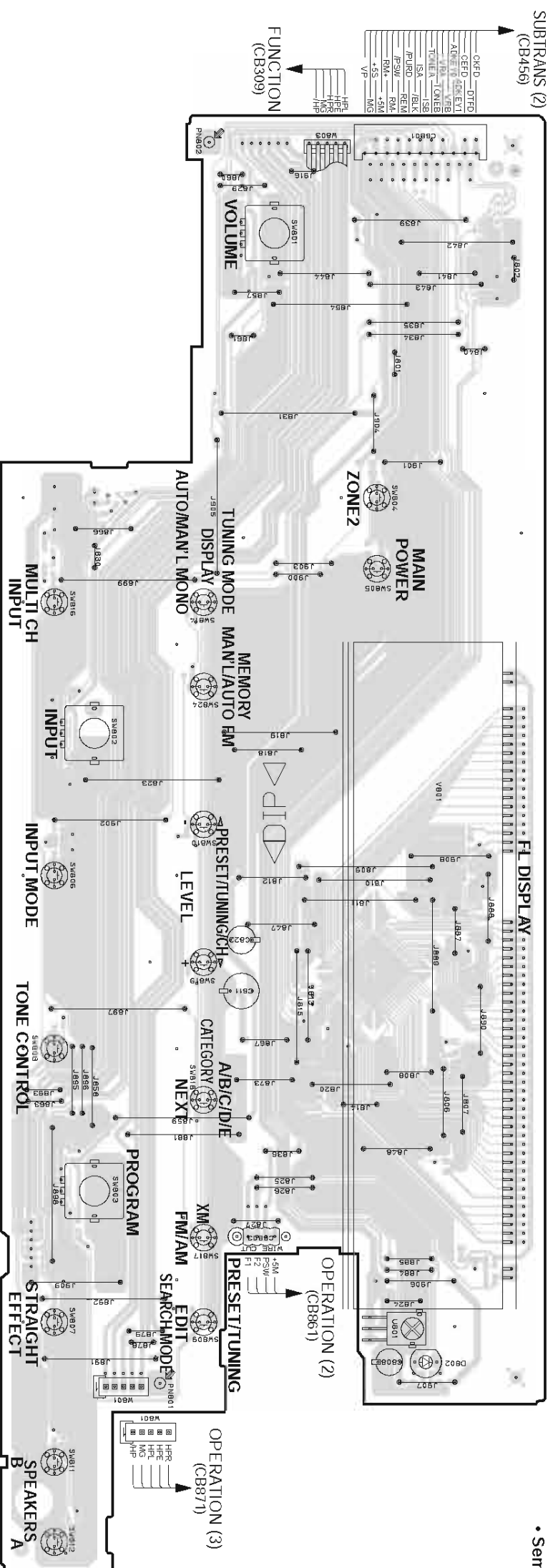

• Semiconductor Location

Ref. No.	Location
D802	I2
D803	H5
D804	H5
D805	D5
D806	E5
D807	D5
D808	D5
IC801	G5
Q801	F5
Q802	F5
Q803	G5
Q804	G5
Q805	H5
Q806	G5
Q808	F5

OPERATION (1) P.C.B.

(Side B)

Lead Free Solder Used

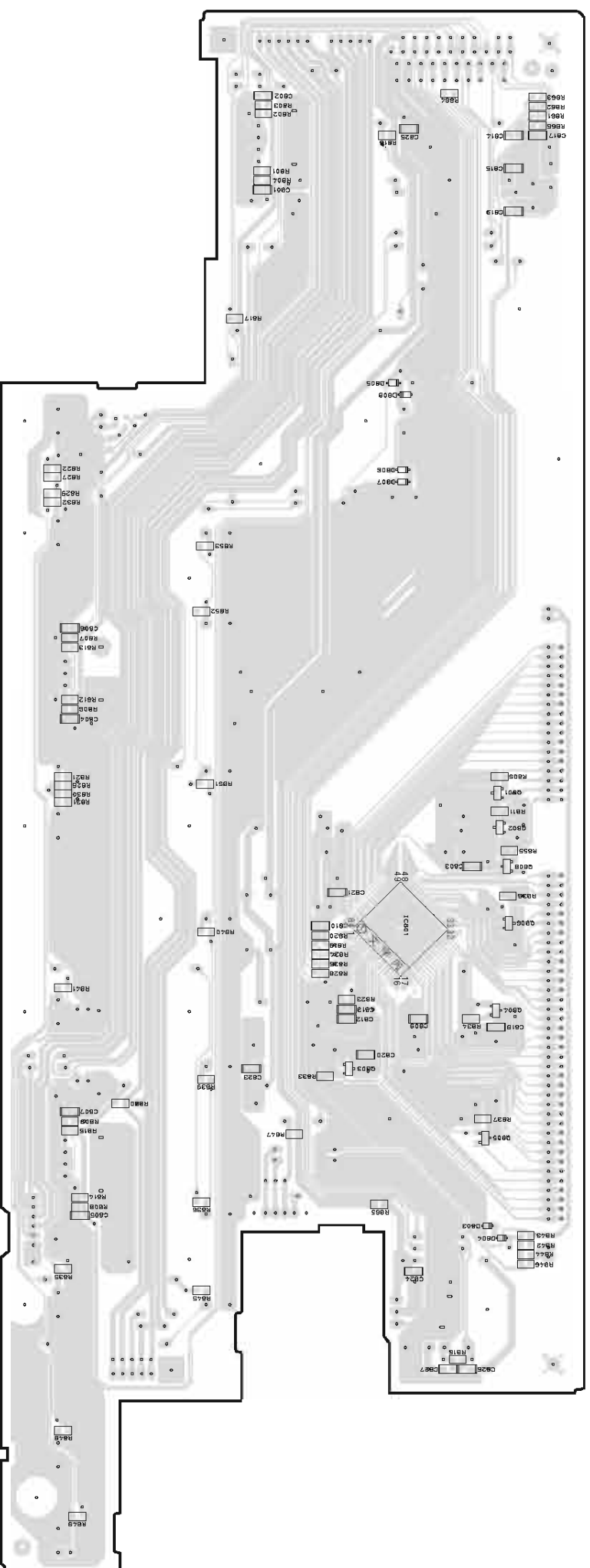

1 PRINTED CIRCUIT BOARD (Foil side) RX-V557/DSP-AX557

OPERATION (2) P.C.B. (Side A)

OPERATION (1) (CB803)

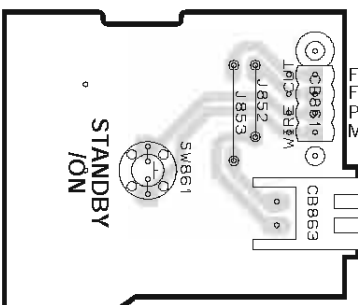

OPERATION (5) P.C.B. (Side A)

FUNCTION (CB306)

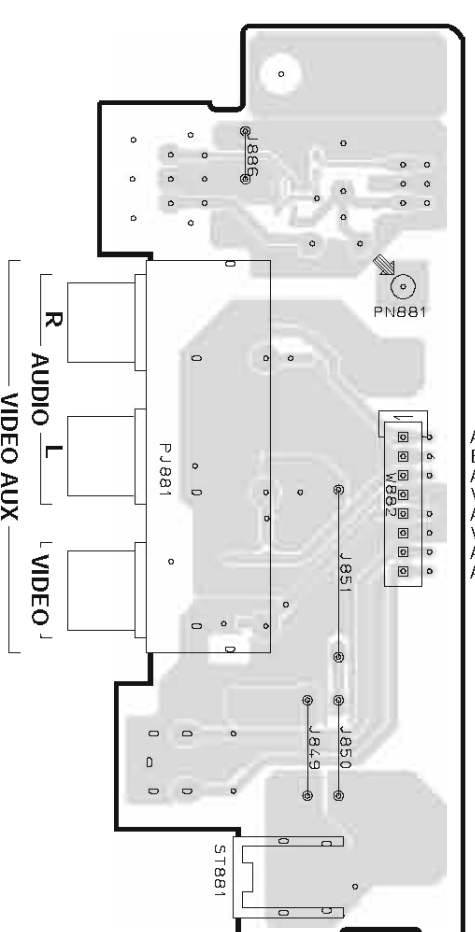

• Semiconductor Location

Ref. No.	Location
D871	D6
D872	D6
D873	D6
D881	I5
D882	I5
D883	H5
D894	H5

OPERATION (3) P.C.B. (Side A)

OPERATION (1) (W801)

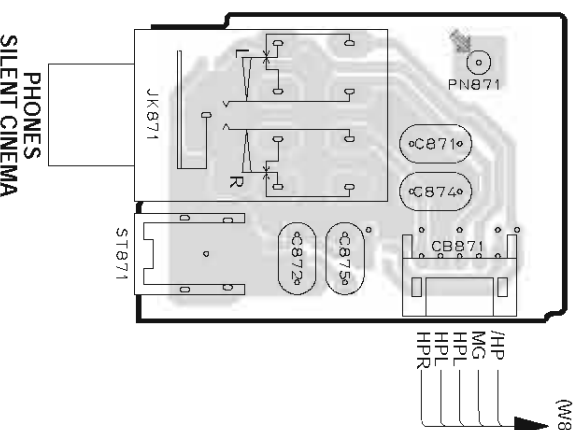

OPERATION (3) P.C.B. (Side B)

Lead Free Solder Used

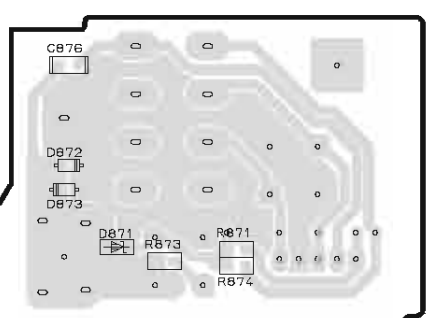

OPERATION (5) P.C.B. (Side B) Lead Free Solder Used

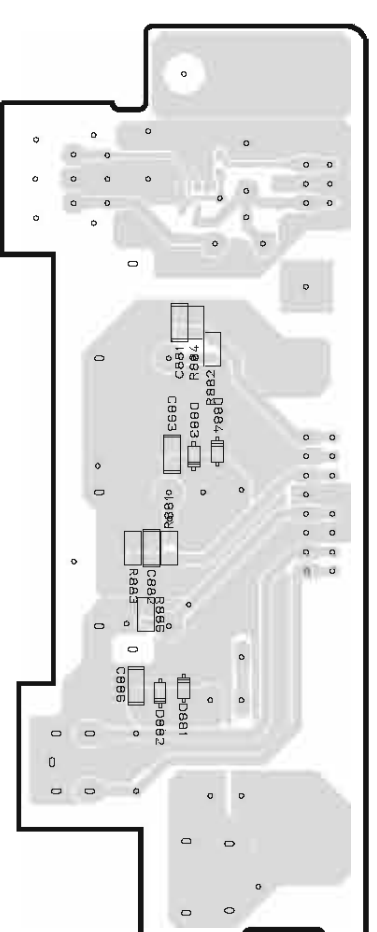

RX-V457/HTR-5850/DSP-AX457
RX-V457/HTR-5840/DSP-AX457

PRINTED CIRCUIT BOARD (Foil side) HTR-5850 RX-V457/HTR-5840/DSP-AX457

• Semiconductor Location

Ref. No.	Location
D803	H5
D804	H5
D805	G5
IC801	F5
Q801	F5
Q802	F5
Q803	H5
Q804	H5
Q805	H5
Q806	G5
Q807	F5

OPERATION (1) P.C.B.
(Side A)

SUBTRANS (2)
(CB456)

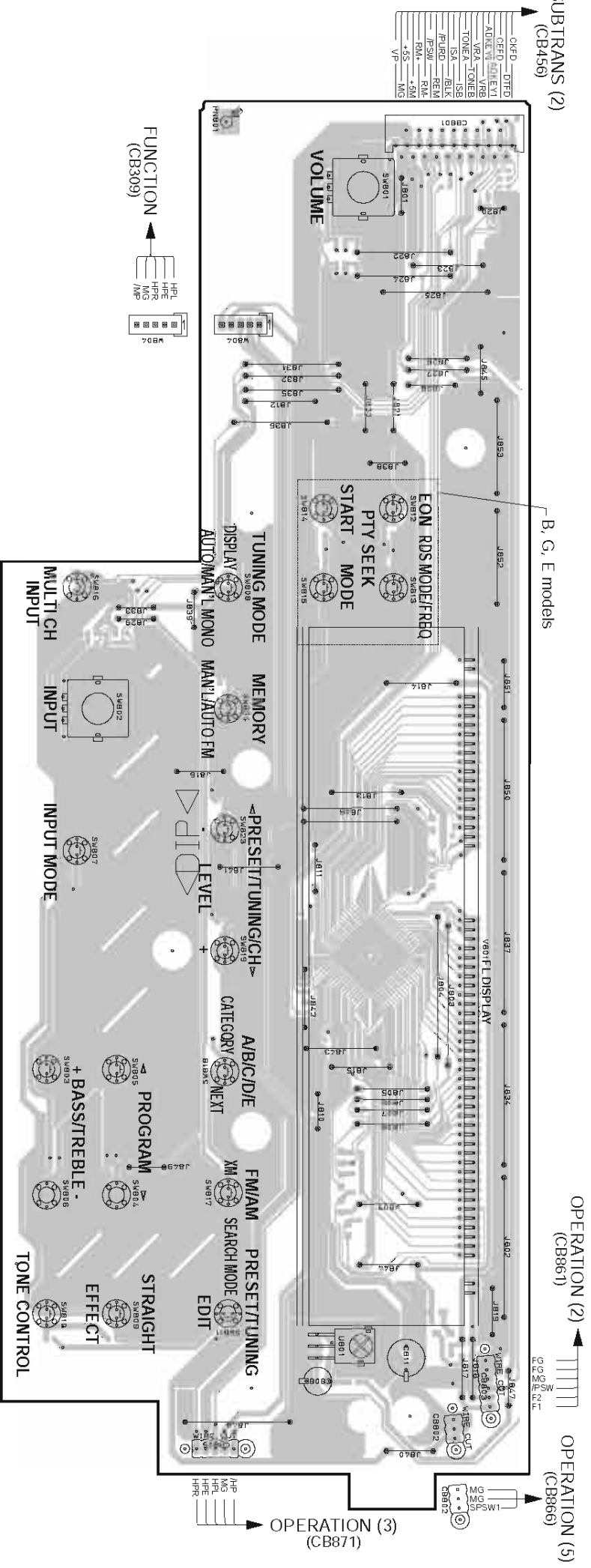

OPERATION (1) P.C.B. (Side B)

Lead Free Solder Used

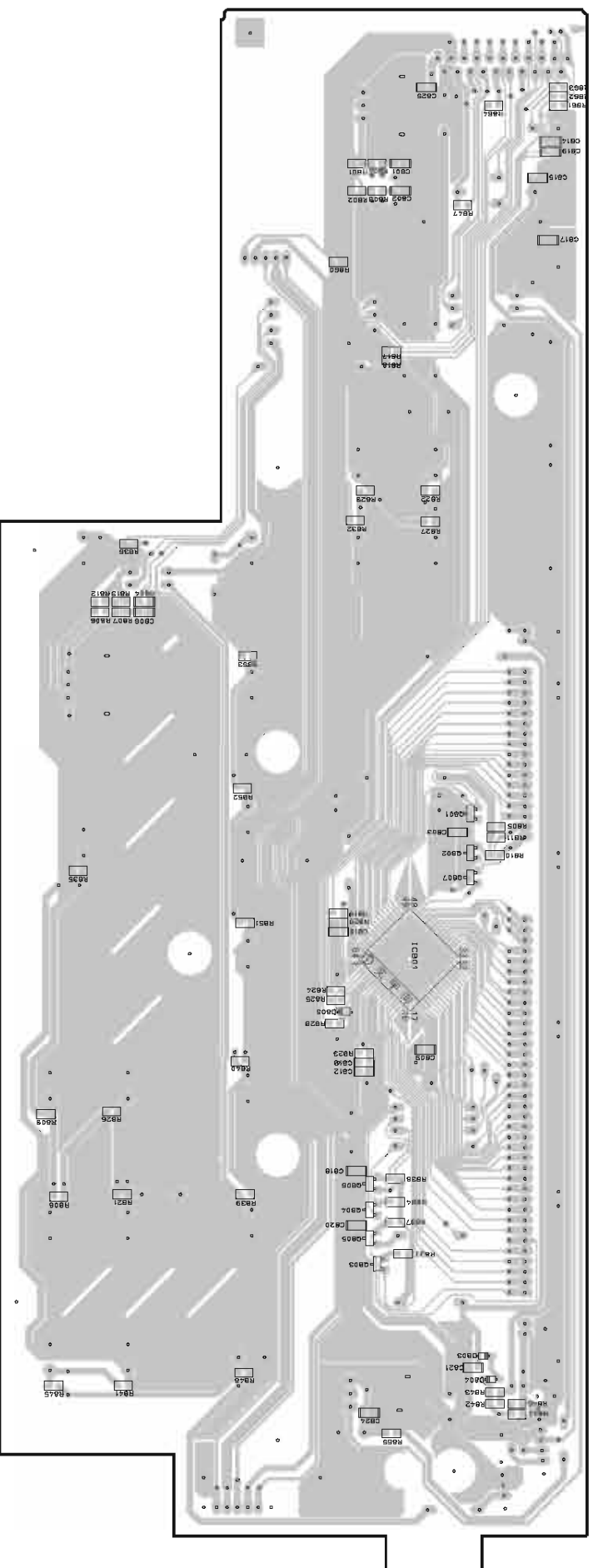

1 ■ PRINTED CIRCUIT BOARD (Foil side) **HTR-5850** **RX-V457/HTR-5840/DSP-AX457**

OPERATION (2) P.C.B. (Side A)

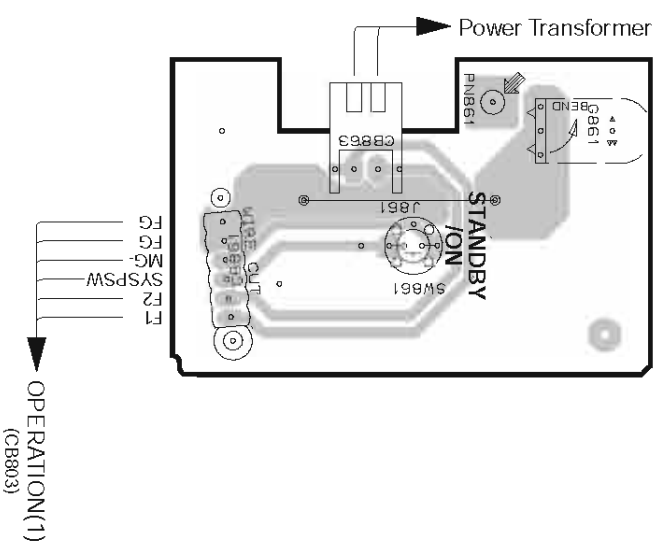

OPERATION (4) P.C.B. (Side A)

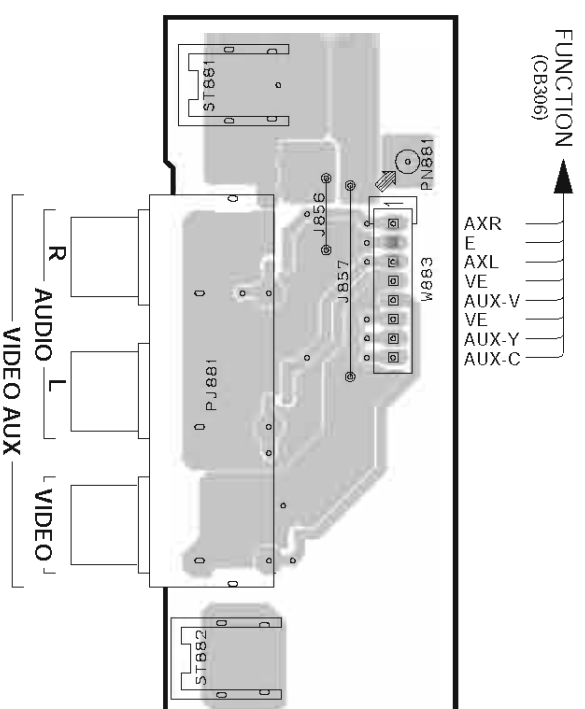

OPERATION (4) P.C.B. (Side B)
Lead Free Solder Used

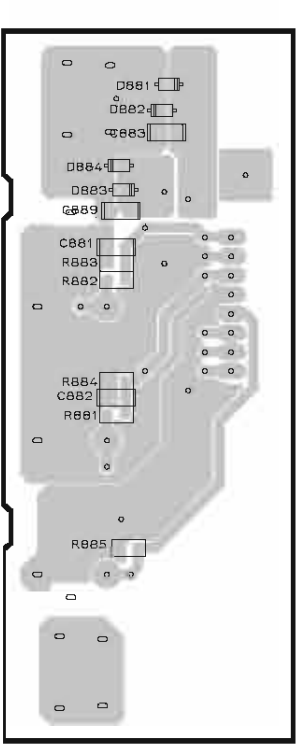

OPERATION (3) P.C.B. (Side A)

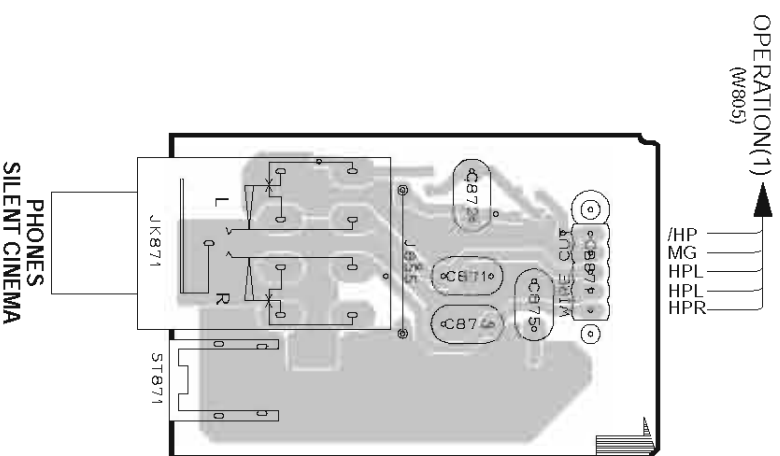

OPERATION (3) P.C.B. (Side B)
Lead Free Solder Used

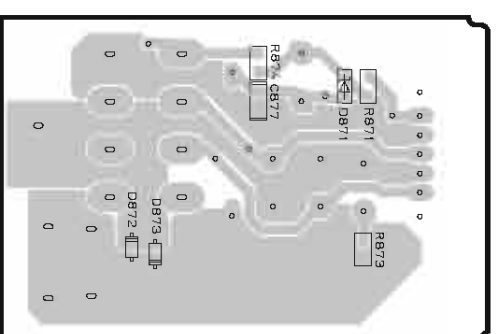

OPERATION (5) P.C.B. (Side A)

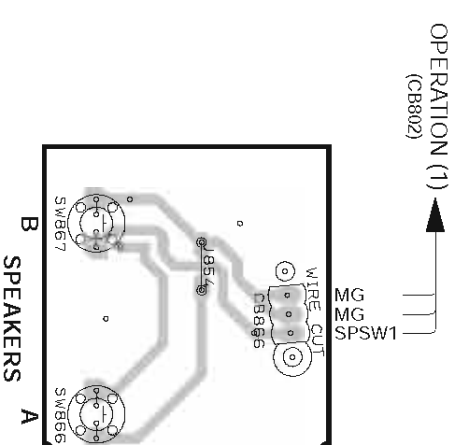

OPERATION (5) P.C.B. (Side B)
Lead Free Solder Used

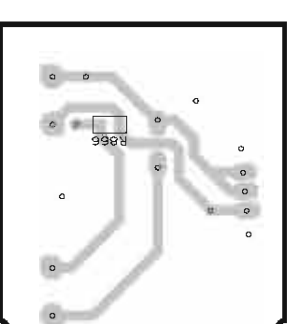

• Semiconductor Location

Ref. No.	Location
D871	D5
D872	D6
D873	D6
D881	H3
D882	H3
D883	I3
D884	H3

PRINTED CIRCUIT BOARD (Foil side) Lead Free Solder Used

MAIN (1) P.C.B. (Side A)

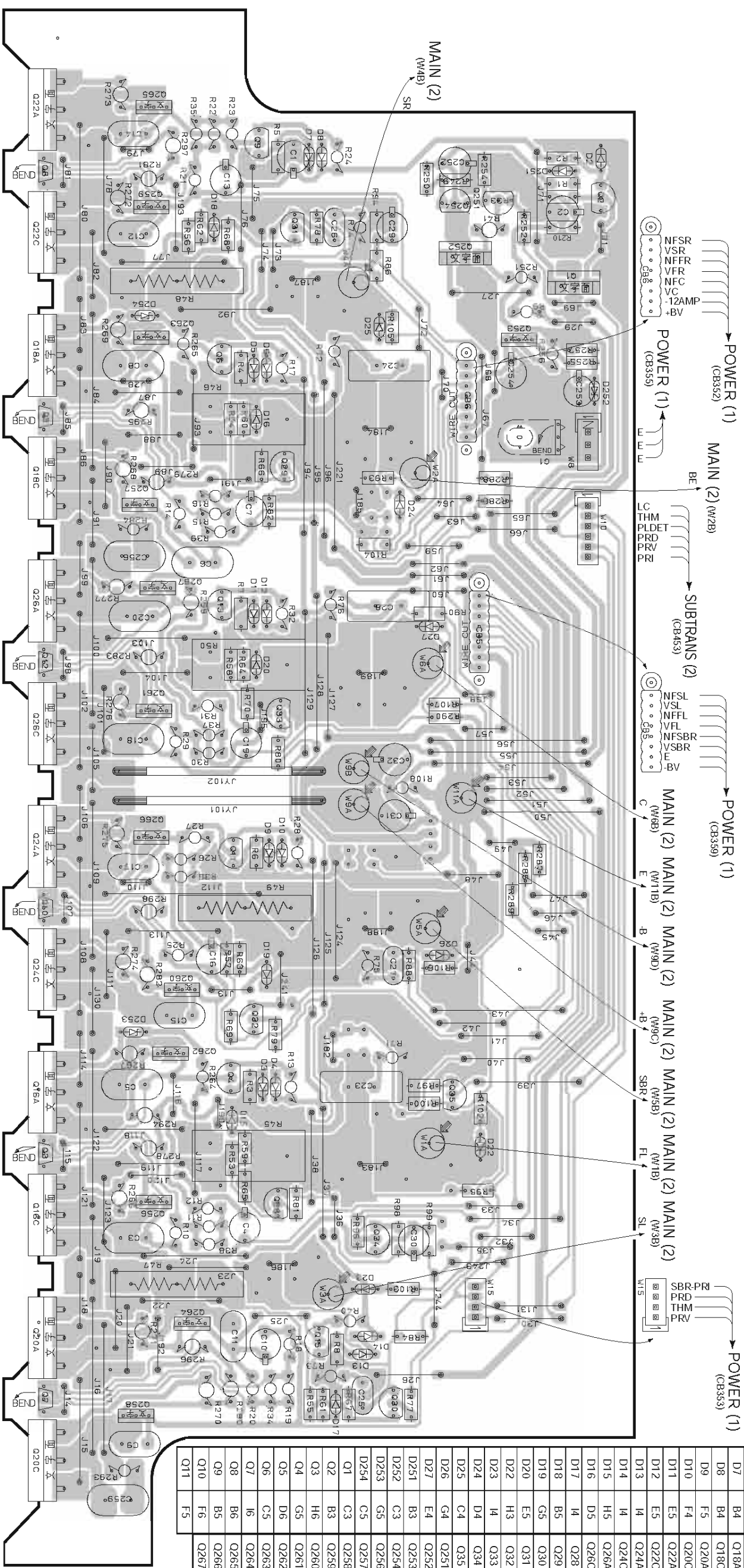

Semiconductor Location

Ref. No.	Location	Ref. No.	Location
D2	B3	Q12	E6
D3	G5	Q13	E5
D4	G5	Q15	I4
D5	C5	Q16A	G6
D6	C5	Q16C	H6
D7	B4	Q18A	C6
D8	B4	Q18C	D6
D9	F4	Q20A	I6
D10	F4	Q20C	I6
D11	E5	Q22A	B6
D12	E5	Q22C	B6
D13	I4	Q24A	F6
D14	I4	Q24C	G6
D15	H5	Q26A	E6
D16	D5	Q26C	E6
D17	I4	Q28	H5
D18	B5	Q29	D4
D19	G5	Q30	I4
D20	E5	Q31	B4
D22	H3	Q32	G5
D23	I4	Q33	E4
D24	D4	Q34	H4
D25	C4	Q35	G4
D26	G4	Q251	B3
D27	E4	Q252	C3
D251	B3	Q253	C3
D252	C3	Q254	B3
D253	G5	Q256	H5
D254	C5	Q257	D5
Q1	C3	Q258	I5
Q2	B3	Q259	B5
Q3	H6	Q260	G5
Q4	G5	Q261	E5
Q5	D6	Q262	G5
Q6	C5	Q263	C5
Q7	I6	Q264	I5
Q8	B6	Q265	B5
Q9	B5	Q266	F5
Q10	F6	Q267	D5
Q11	F5		

Circuit No.	LITERIAL K.E.G.L.E
C130, 131, 134, 141	X
T120, 121	X
	O
	X NOT USED / O USED

1 ■ PRINTED CIRCUIT BOARD (Foil side) Lead Free Solder Used

MAIN (2) P.C.B. (Side A)

FRONT

SPEAKERS

CENTER SURROUND

SURROUND BACK

• Semiconductor Location

Ref. No.	Location
D120	E5
D122	I5
D123	F4
D125	D5
D127	C5
D129	B5
D133	G5
D134	H4
D141	I4
D142	I4
D143	I4
D144	I4
Q120	I5
Q121	D5
Q123	E5
Q124	E5
Q125	C5
Q126	B5
Q127	H4

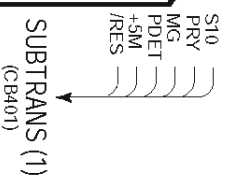
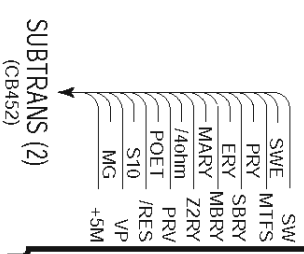
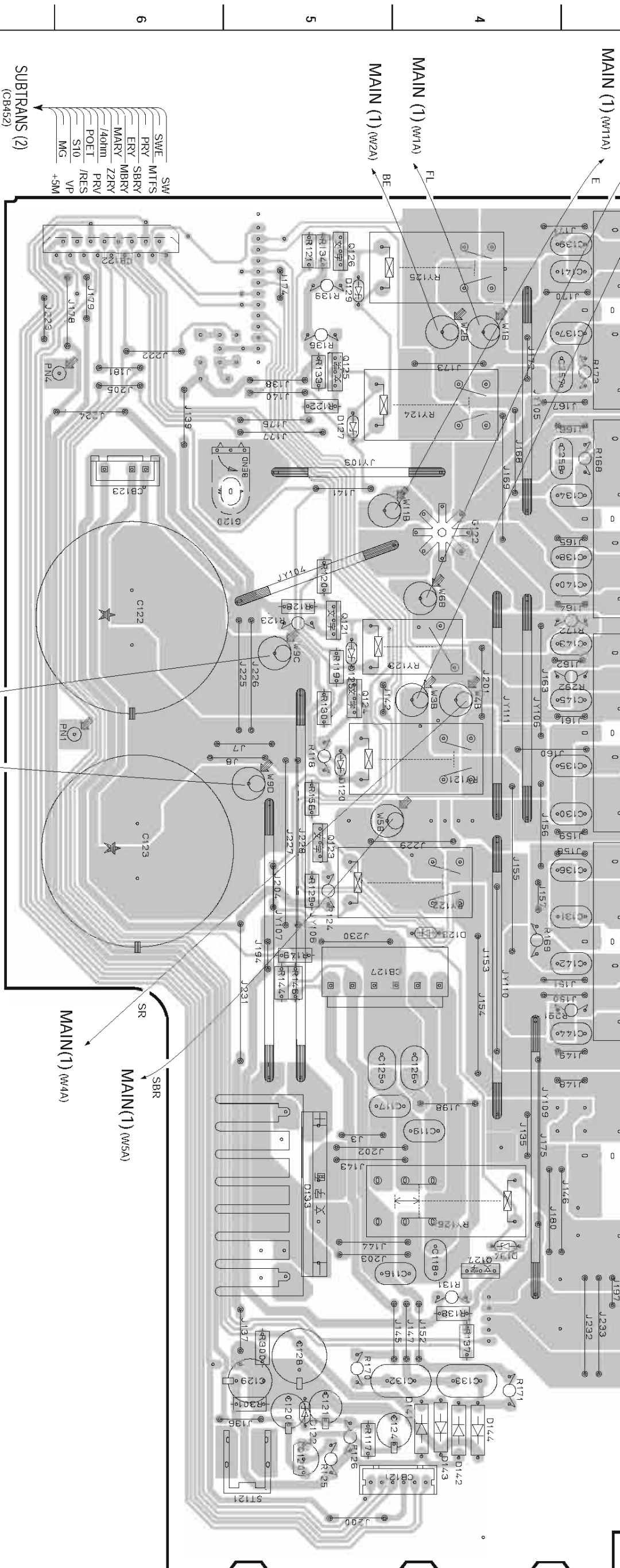

RX-V457/HTR-5850/DSP-AX457
RX-V457/HTR-5840/DSP-AX457

PRINTED CIRCUIT BOARD (Foil side) Lead Free Solder Used

POWER (1) P.C.B. (Side A)

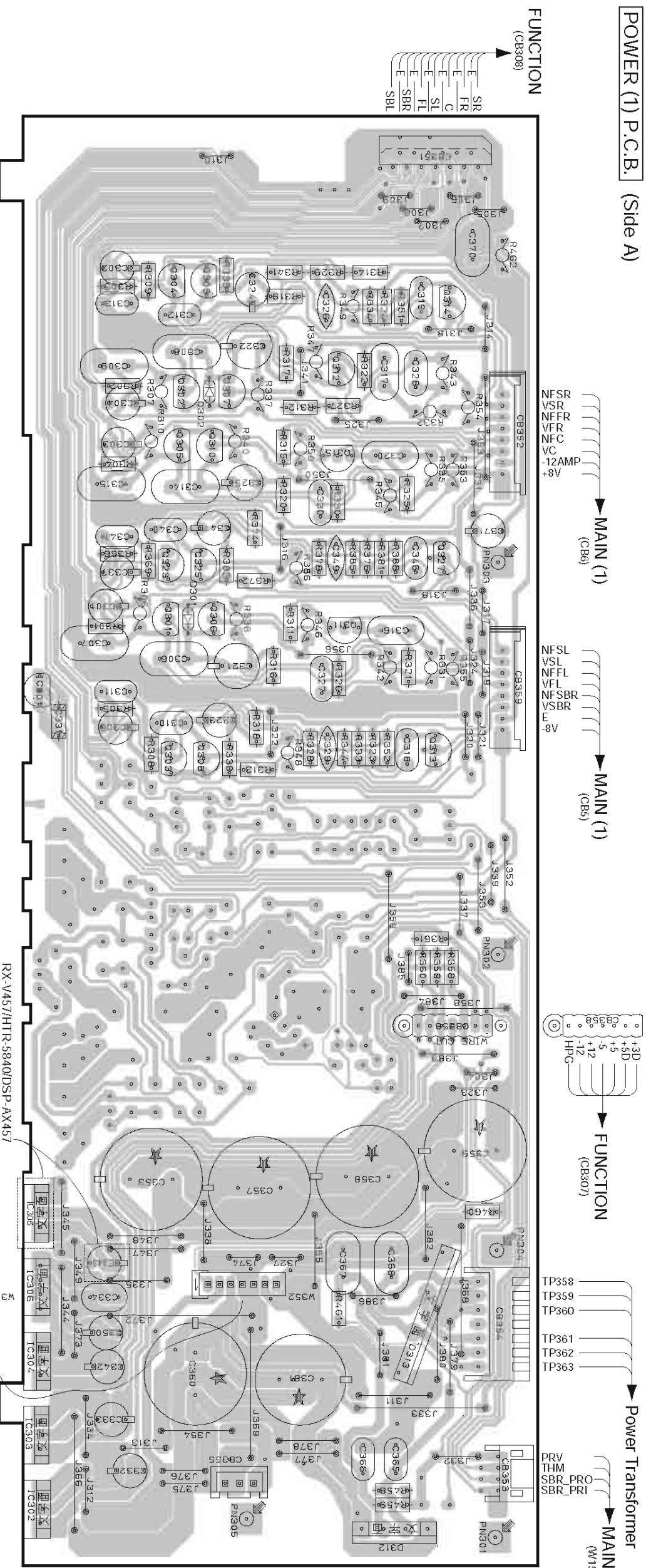

Semiconductor Location

Ref. No.	Location
D301	D4
D302	C4
D312	J3
D313	H3
IC301	E5
IC302	I5
IC303	I5
IC304	H5
IC305	G5
IC306	H5
IC307	H4
IC308	E4
IC309	B4
IC310	C4
IC311	D3
IC312	C3
IC313	E3
IC314	B3
IC315	C3
IC323	D4
IC325	D4
IC327	D3

POWER (2) P.C.B. (Side A)

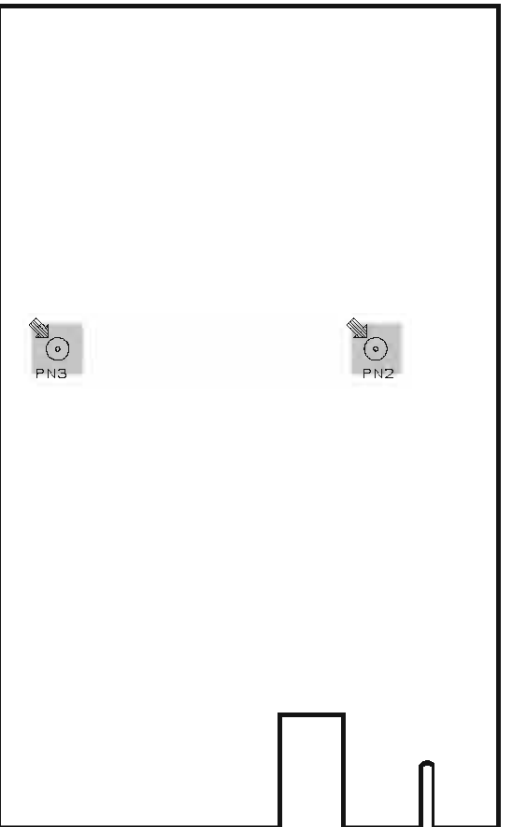

Original Part	RX-V457/HTR-5850/DSP-AX457	RX-V457/HTR-5840/DSP-AX457
IC13	X	O
IC305	X	O
R362	X	O
W352	X	O

X: NOT USED / O: USED

1 ■ PRINTED CIRCUIT BOARD (Foil side) ■ RX-V557/DSP-AX557
HTR-5850 (T, K models)

SUBTRANS (1) P.C.B. (Side A)

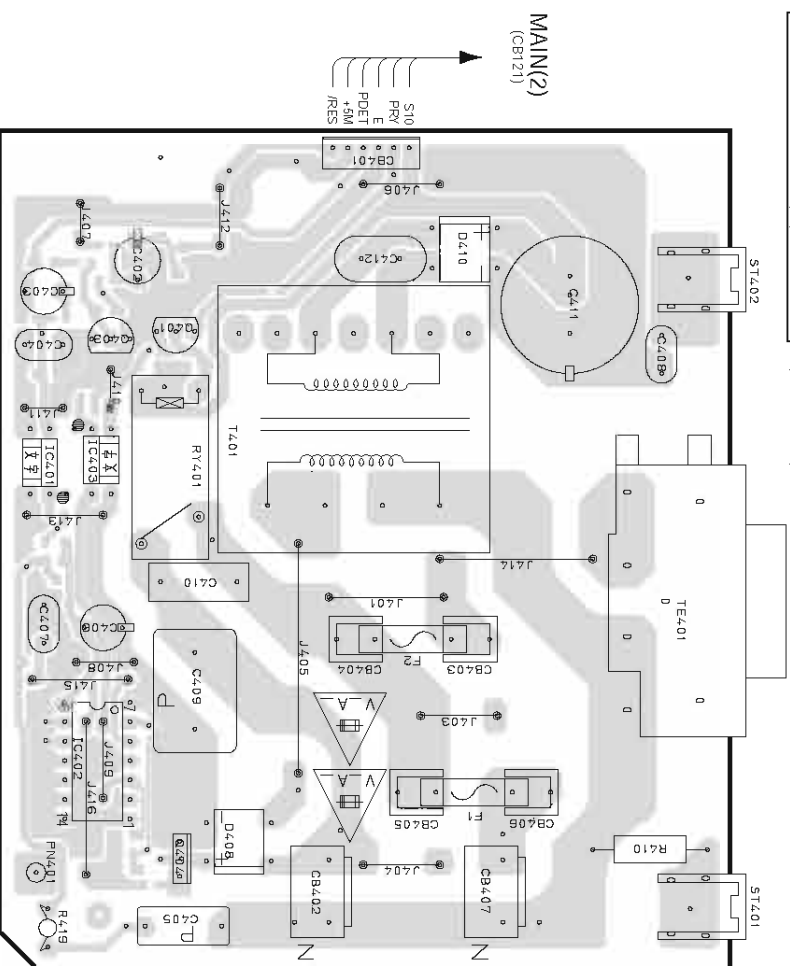

SUBTRANS (1) P.C.B. (Side B) Lead Free Solder Used

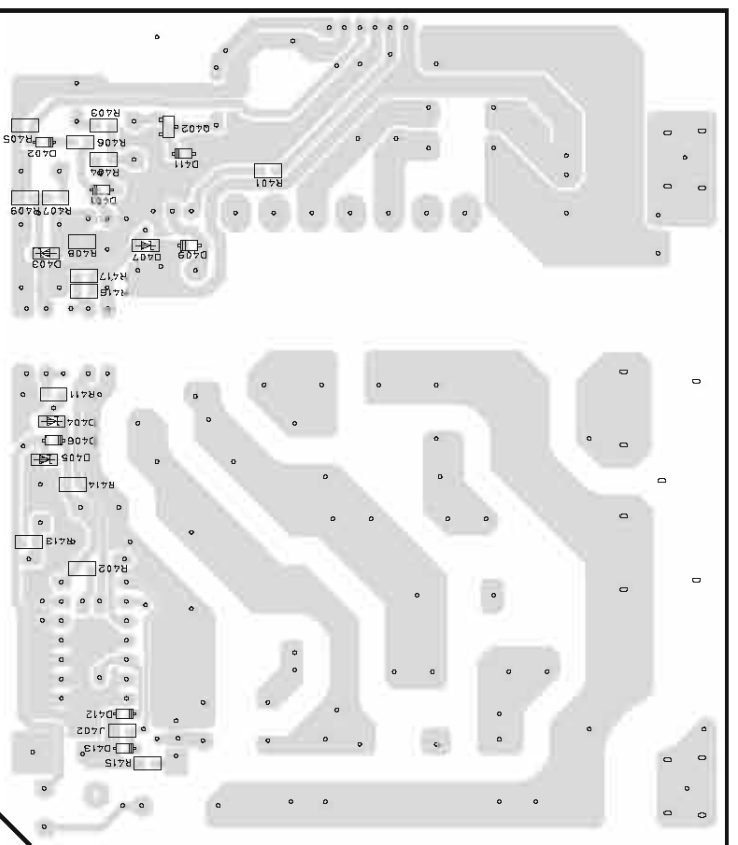

SUBTRANS (3) P.C.B. (Side A)

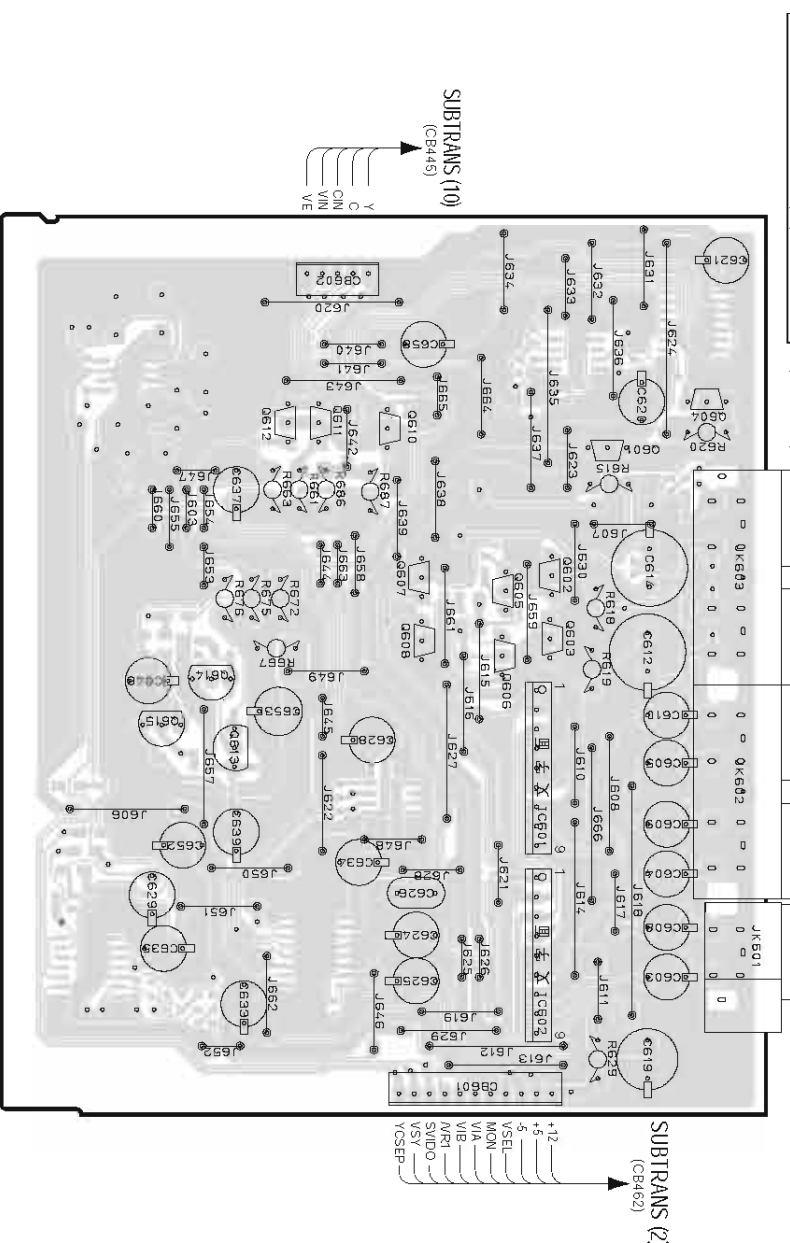

SUBTRANS (3) P.C.B. (Side B) Lead Free Solder Used

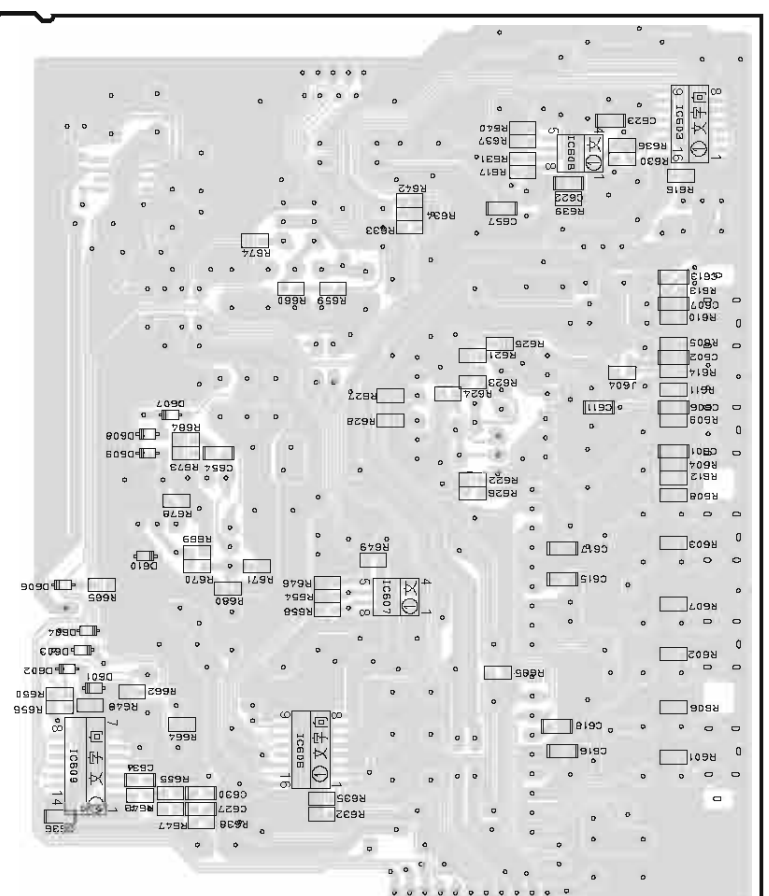

• Semiconductor Location

Ref. No.	Location
D401	B7
D402	B7
D403	B7
D404	C7
D405	C7
D406	C7
D407	B7
D408	C4
D409	B7
D410	B3
D411	B7
D412	D7
D413	D7
D601	H7
D602	H7
D603	H7
D604	H7
D605	H7
D606	G7
D608	G7
D609	G7
D610	H7
IC401	B4
IC402	C4
IC403	B4
IC601	G2
IC602	H2
IC603	F5
IC606	H6
IC607	H6
IC608	F5
IC609	H7
Q401	B4
Q402	B7
Q403	B4
Q404	D4
O601	G2
O602	G2
O603	G2
O604	F2
O605	G3
O606	G3
O607	G3
O608	G3
O610	F3
O611	F3
O612	F3
O613	H4
O614	G4
O615	G4

RX-V557/HTR-5850/DSP-AX557
RX-V457/HTR-5840/DSP-AX457

PRINTED CIRCUIT BOARD (Foil side) **RX-V557/DSP-AX557**

SUBTRANS (2) P.C.B. (Side A)

SUBTRANS (2) P.C.B. (Side B) Lead Free Solder Used

• Semiconductor Location

Ref. No.	Location
D451	G3
D452	G3
D453	G3
D454	G3
D455	G3
D456	H4
D457	G3
D458	G3
IC451	G4
IC452	B2
IC453	H3
Q451	B3
Q452	G3
Q453	I4
Q454	I5
Q455	I4
Q456	H6
Q457	H6
Q458	C2
Q459	C3

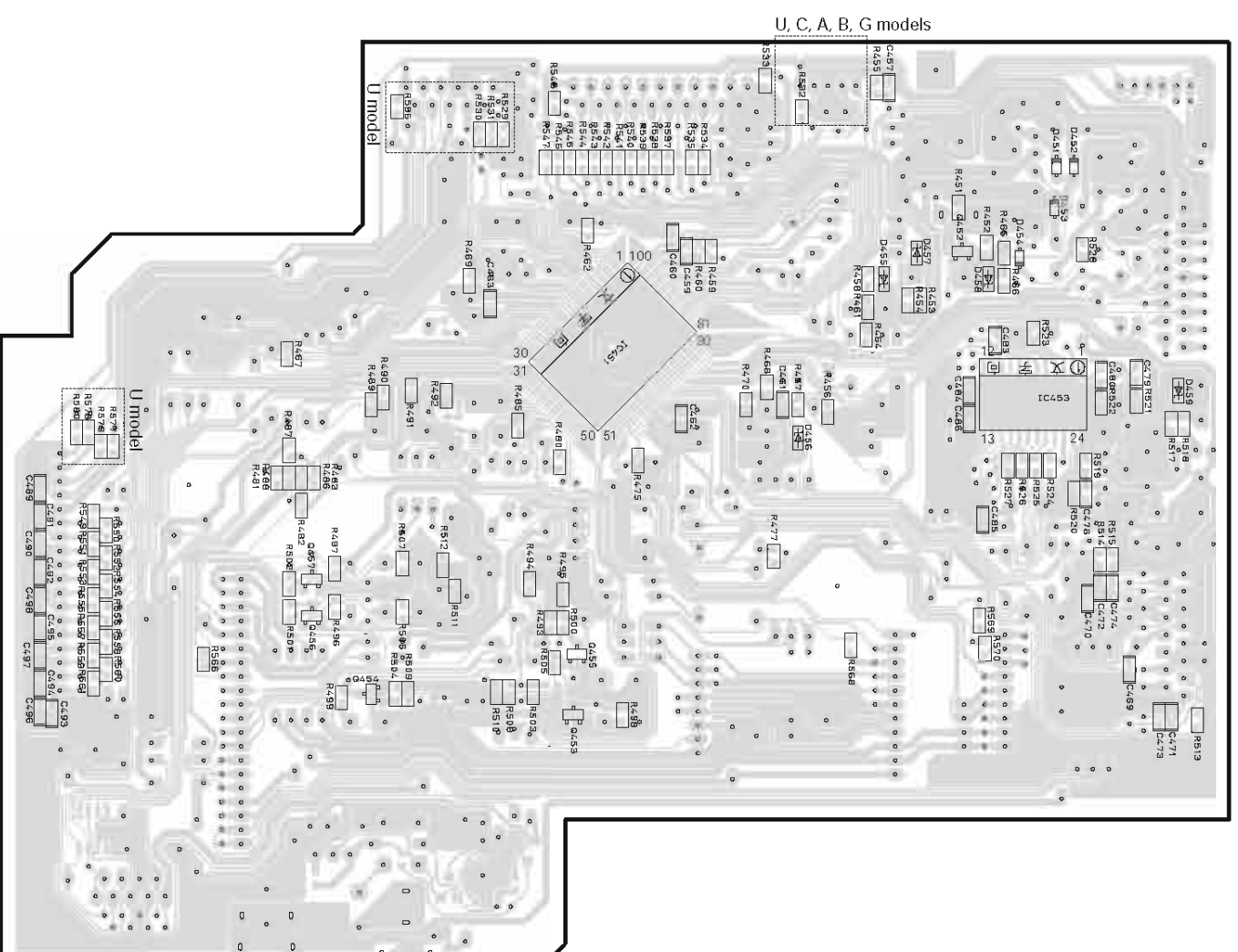
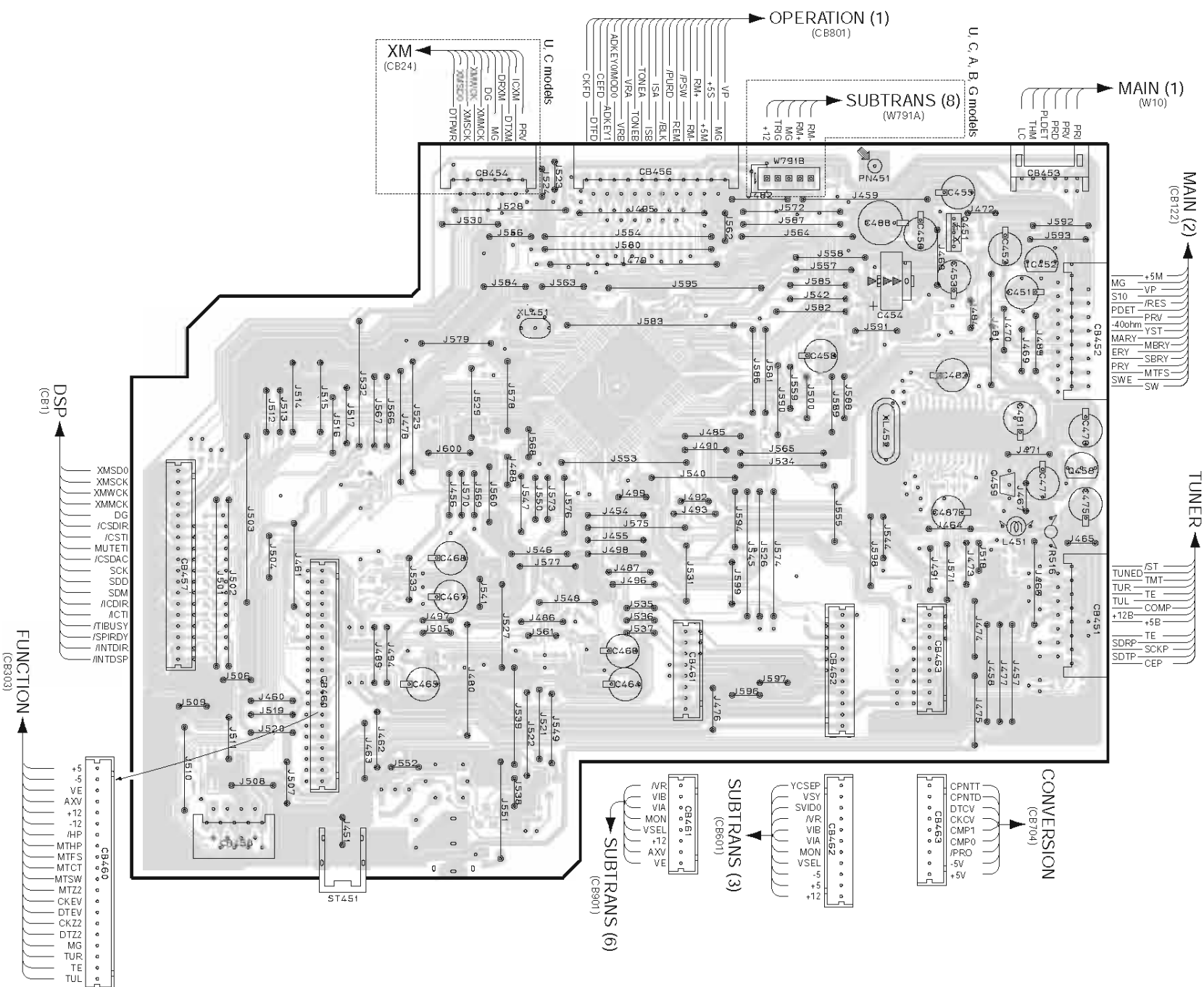

1 ■ PRINTED CIRCUIT BOARD (Foil side) ■ RX-V557/DSP-AX557

SUBTRANS (5) P.C.B. (Side A)
(R, L models)

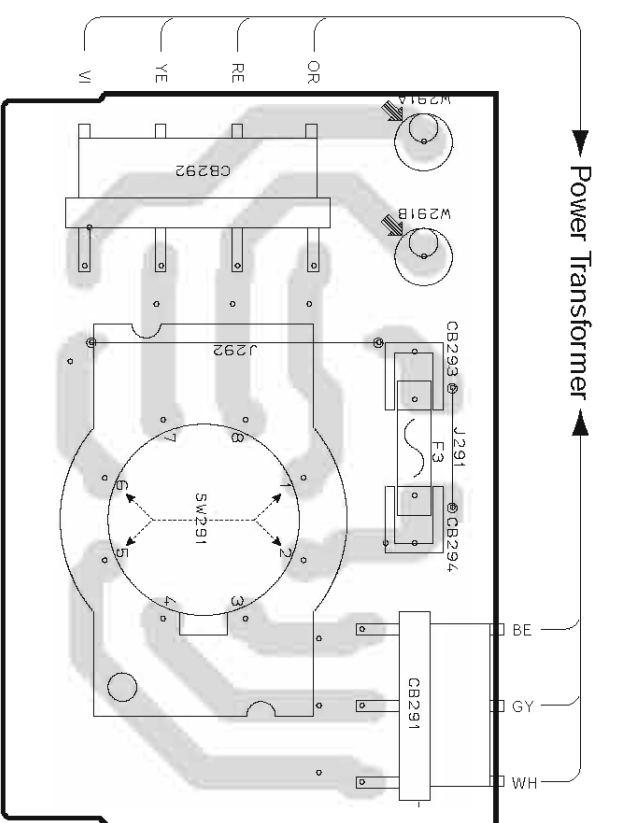

SUBTRANS (6) P.C.B. (Side A)

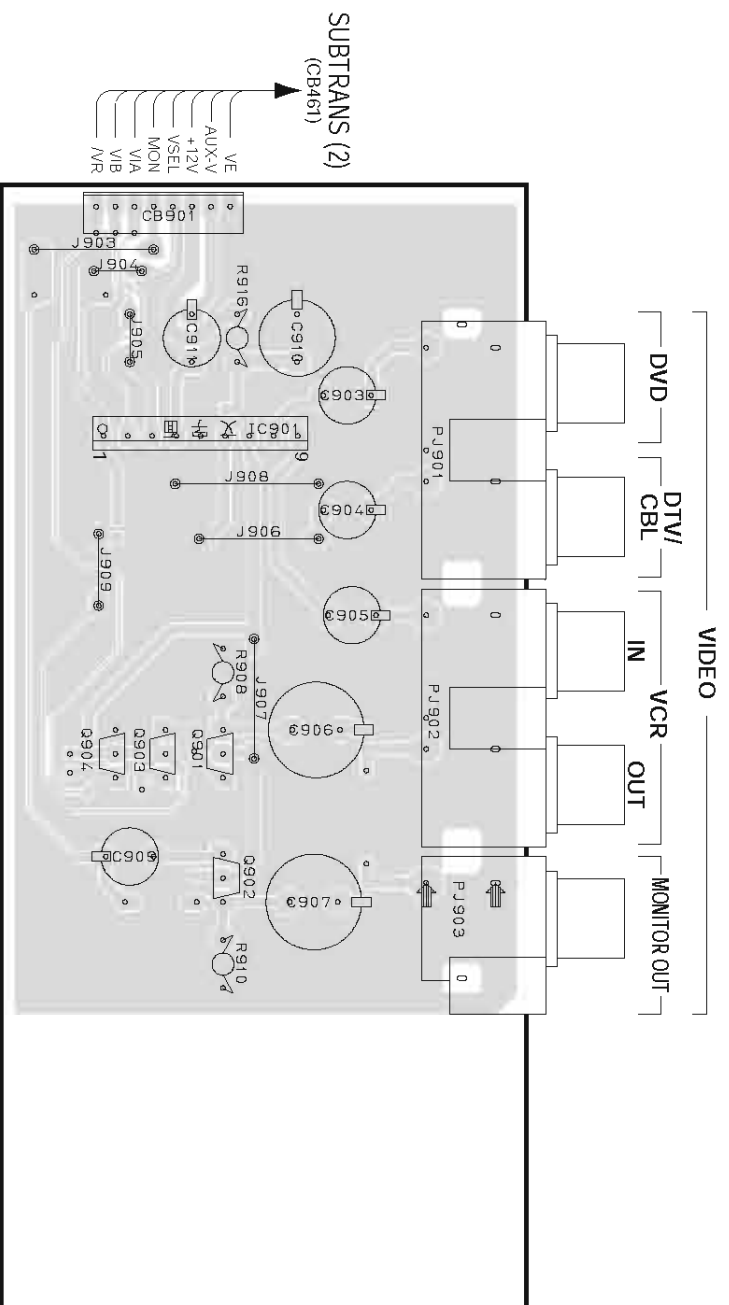

• Semiconductor Location

Ref. No.	Location
D791	C6
D792	D6
D793	D6
IC901	G3
Q791	B6
Q792	D6
Q901	H3
Q902	H3
Q903	H4
Q904	H4

SUBTRANS (8) P.C.B. (Side A)
(U, C, A, B, G models)

REMOTE IN/OUT CONTROL OUT +12V 15mA MAX.

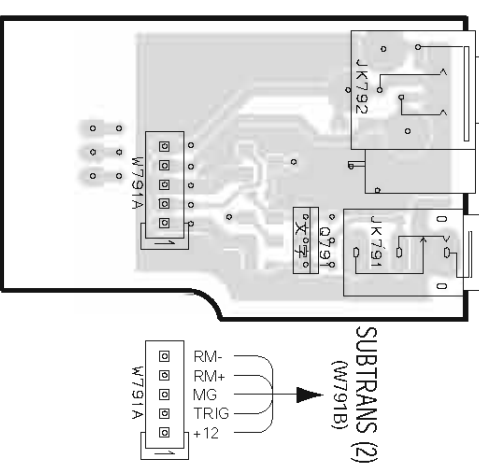

SUBTRANS (8) P.C.B. (Side B)
Lead Free Solder Used
(U, C, A, B, G models)

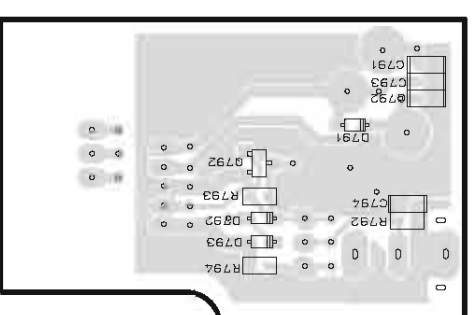

SUBTRANS (6) P.C.B. (Side B) Lead Free Solder Used

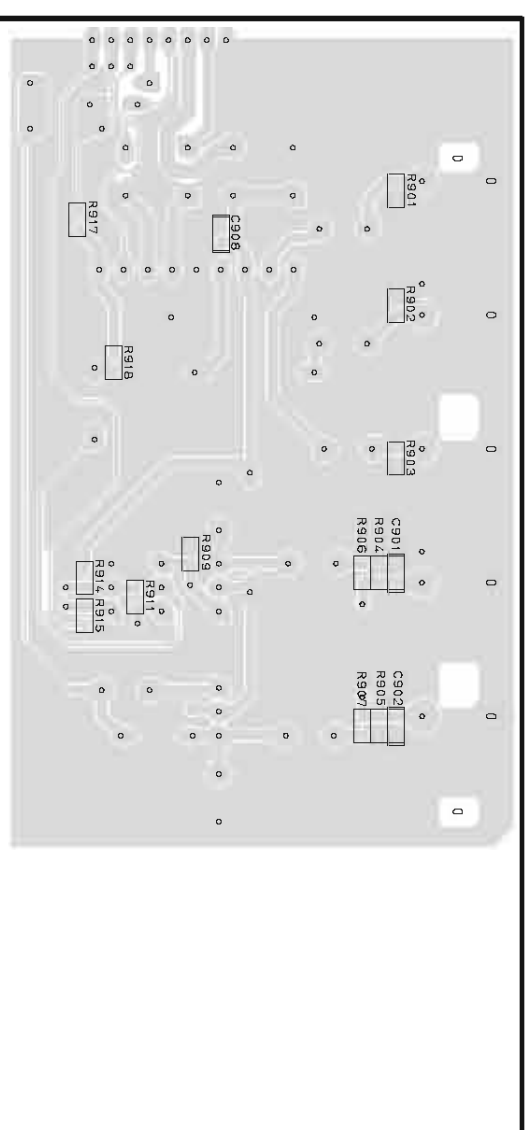

RX-V557/HTR-5850/DSP-AX557
 RX-V457/HTR-5840/DSP-AX457

■ PRINTED CIRCUIT BOARD (Foil side) **RX-V557/DSP-AX557**

SUBTRANS (7) P.C.B. (Side A)

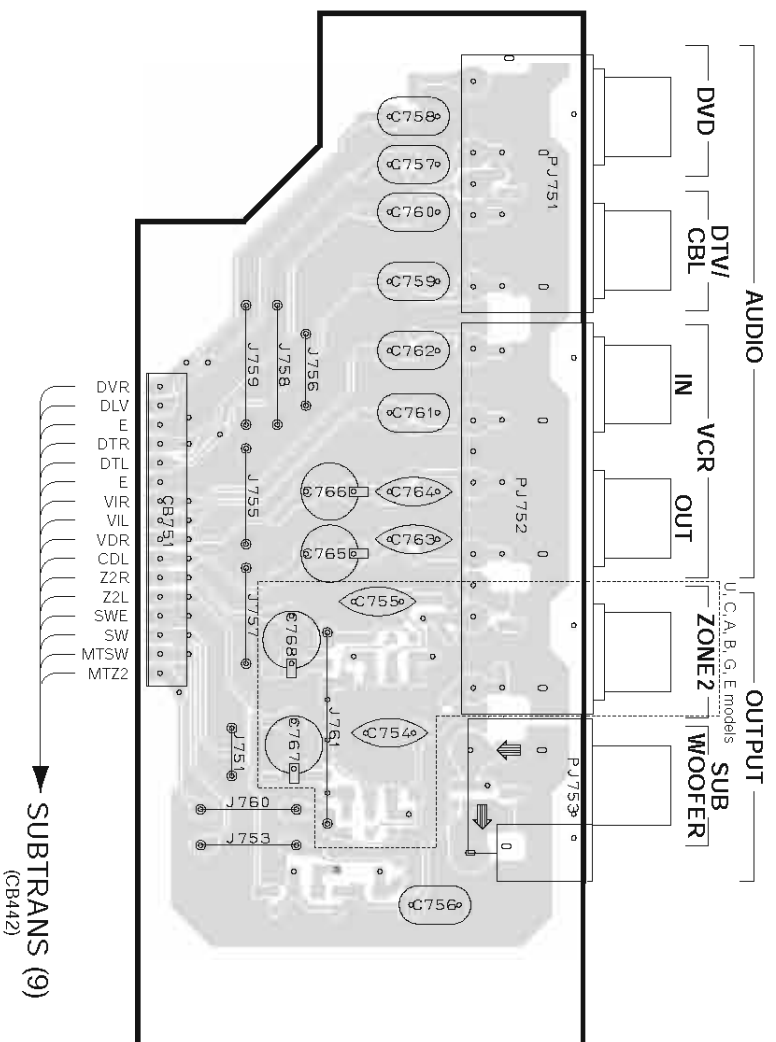

SUBTRANS (9) P.C.B. (Side A)

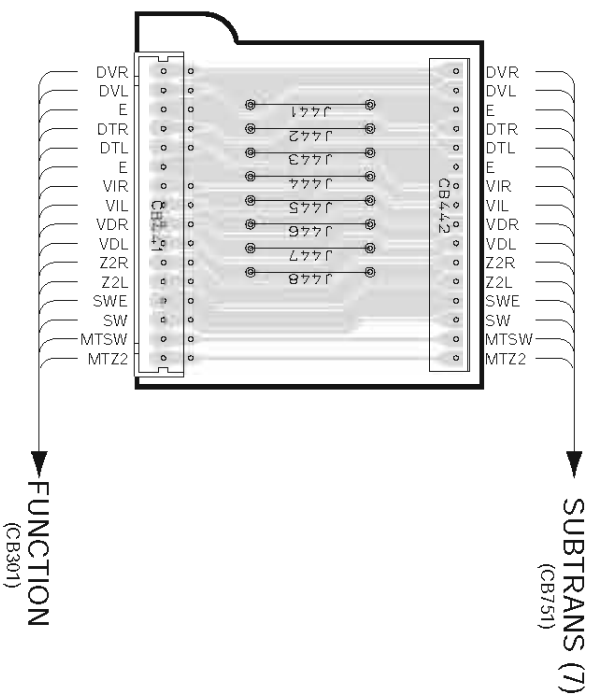

• Semiconductor Location

Ref. No.	Location
0751	D6
0752	D6
0754	D6
0755	D6

SUBTRANS (7) P.C.B. (Side B) Lead Free Solder Used

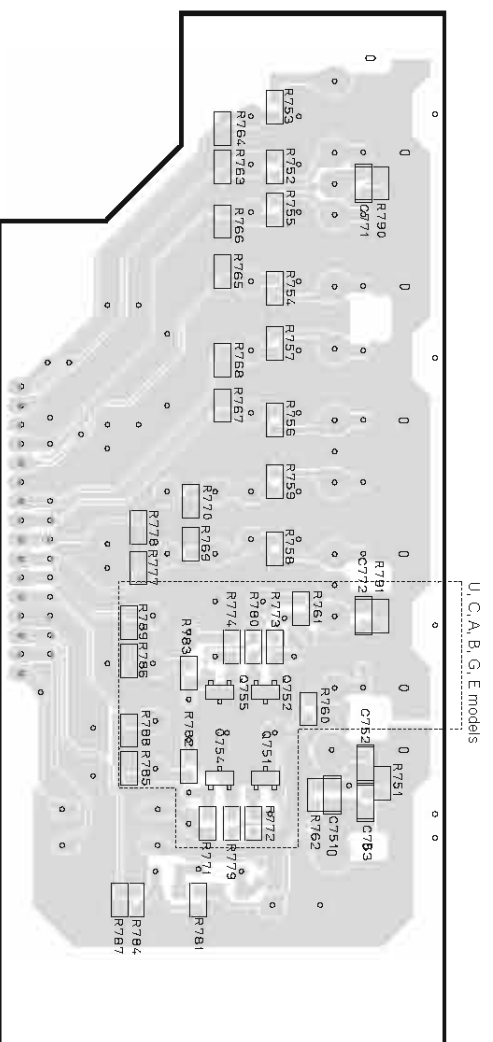

SUBTRANS (10) P.C.B. (Side A)

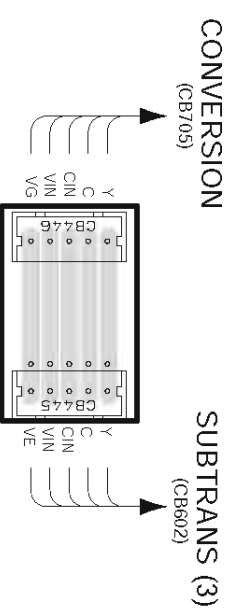

1 ■ PRINTED CIRCUIT BOARD (Foil side) **HTR-5850**

SUBTRANS (1) P.C.B. (Side A)

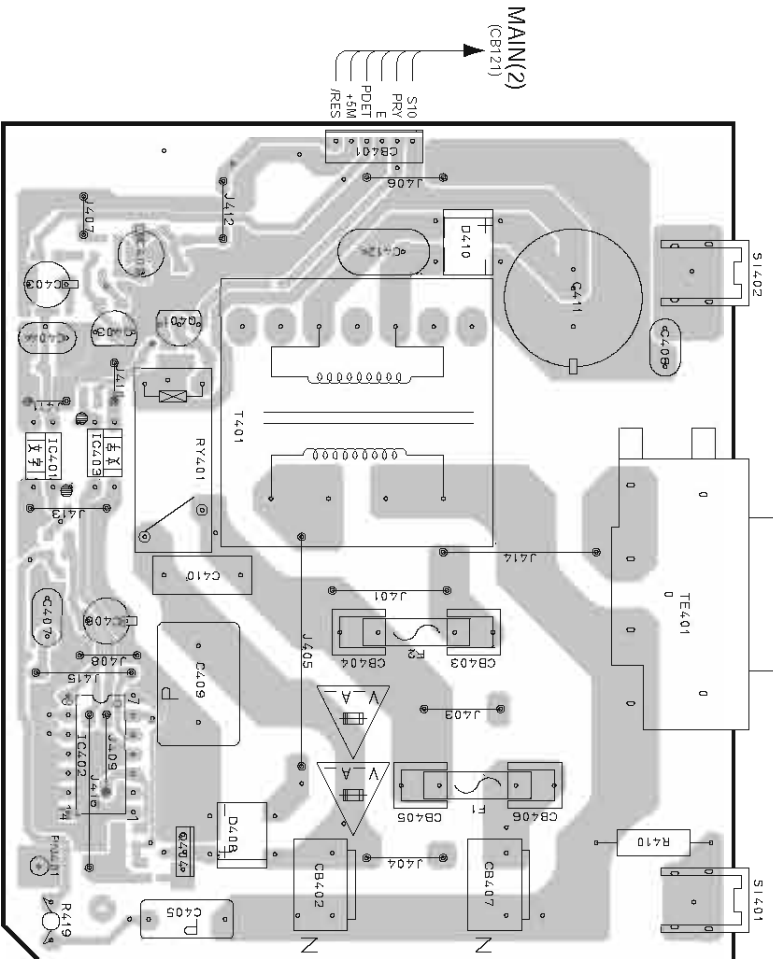

SUBTRANS (1) P.C.B. (Side B) Lead Free Solder Used

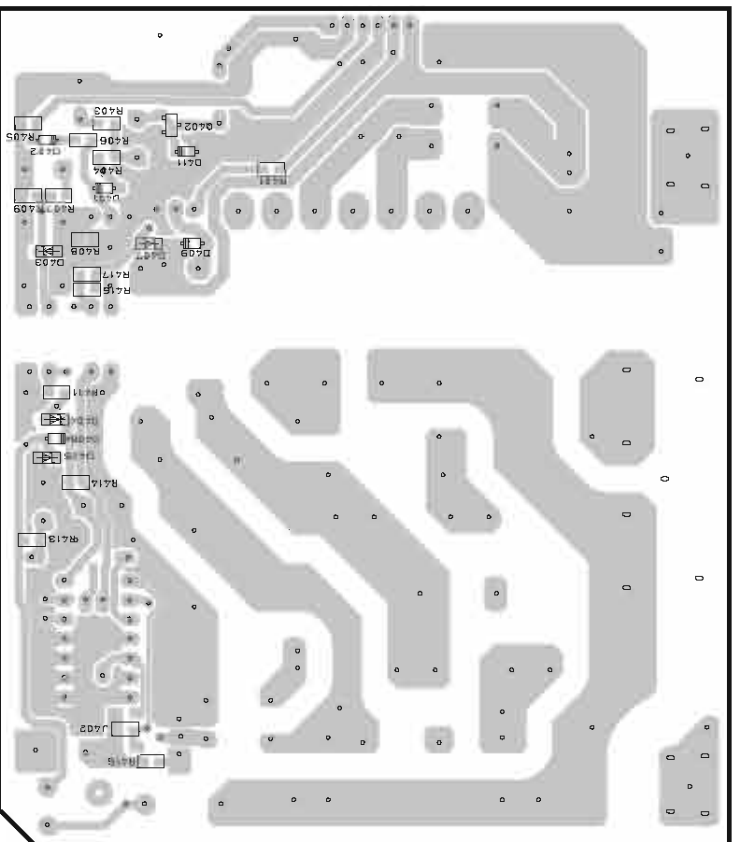

SUBTRANS (3) P.C.B. (Side A)

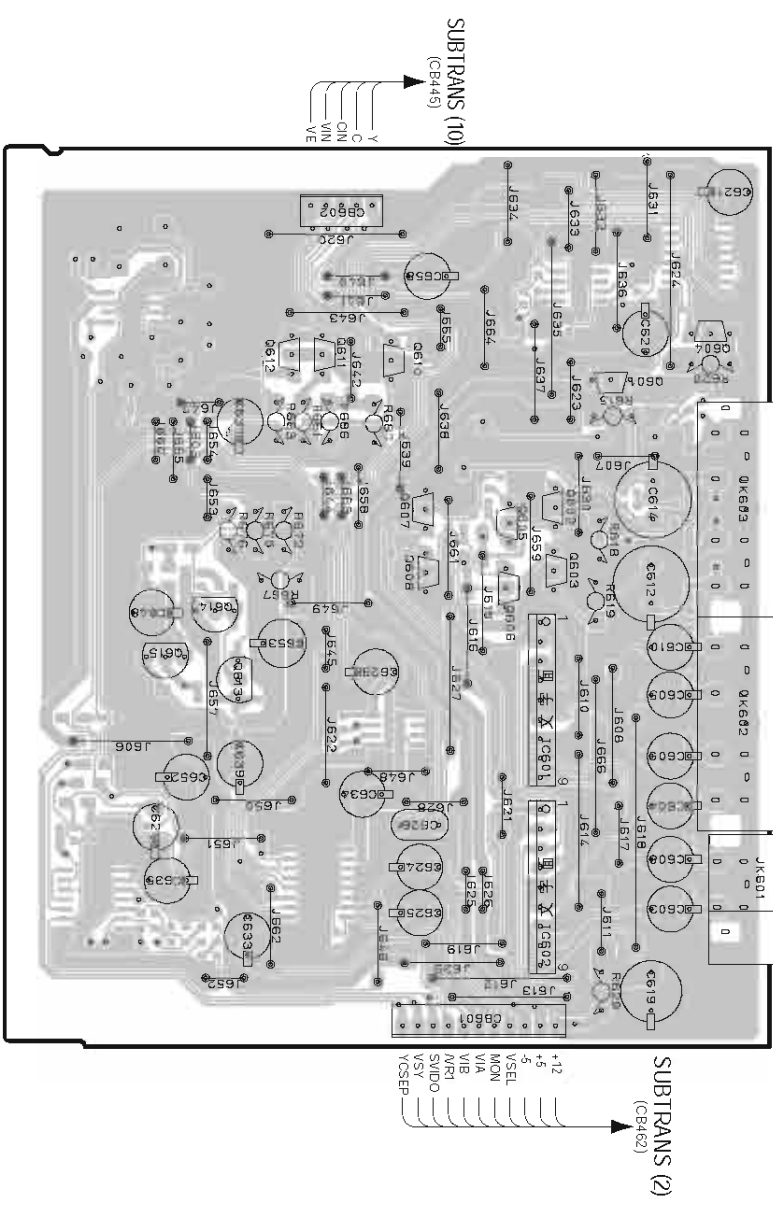

SUBTRANS (3) P.C.B. (Side B) Lead Free Solder Used

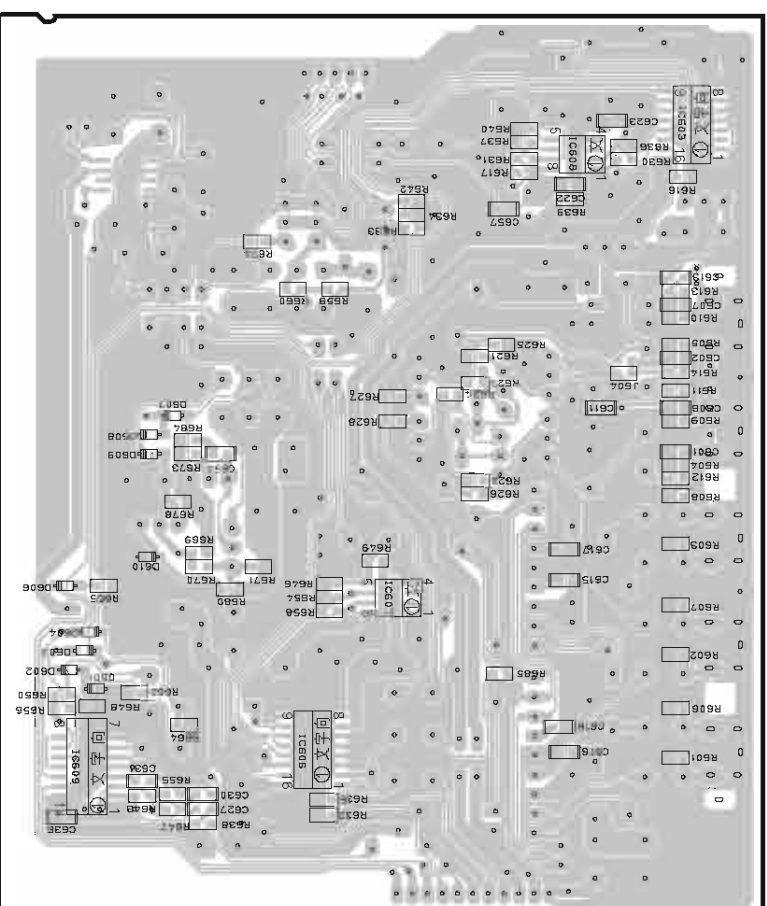

• Semiconductor Location

Ref. No.	Location
D401	B7
D402	B7
D403	B7
D404	C7
D405	C7
D406	C7
D407	B7
D408	C4
D409	B7
D410	B3
D411	B7
D412	D7
D413	D7
D601	H7
D602	H7
D603	H7
D604	H7
D605	H7
D606	G7
D607	G7
D608	G7
D609	G7
D610	H7
IC401	B4
IC402	C4
IC403	B4
IC601	G2
IC602	H2
IC603	F5
IC606	H6
IC607	H6
IC608	F5
IC609	H7
Q401	B4
Q402	B7
Q403	B4
Q404	D4
O601	G2
O602	G2
O603	G2
O604	F2
O605	G3
O606	G3
O607	G3
O608	G3
O610	F3
O611	F3
O612	F3
O613	H4
O614	G4
O615	G4

RX-V557/HTR-5850/DSP-AX557
RX-V457/HTR-5840/DSP-AX457

PRINTED CIRCUIT BOARD (Foil side) HTR-5850

SUBTRANS (2) P.C.B. (Side A)

SUBTRANS (2) P.C.B. (Side B) Lead Free Solder Used

• Semiconductor Location

Ref. No.	Location
D451	F3
D452	F3
D453	G3
D454	G3
D455	G3
D456	H4
D457	G3
D458	G3
D459	G2
D461	I5
IC451	G4
Q451	B3
Q452	G3
Q453	H4
Q455	H4
Q456	H6
Q457	H6
Q458	C2
Q460	I5
Q462	E5

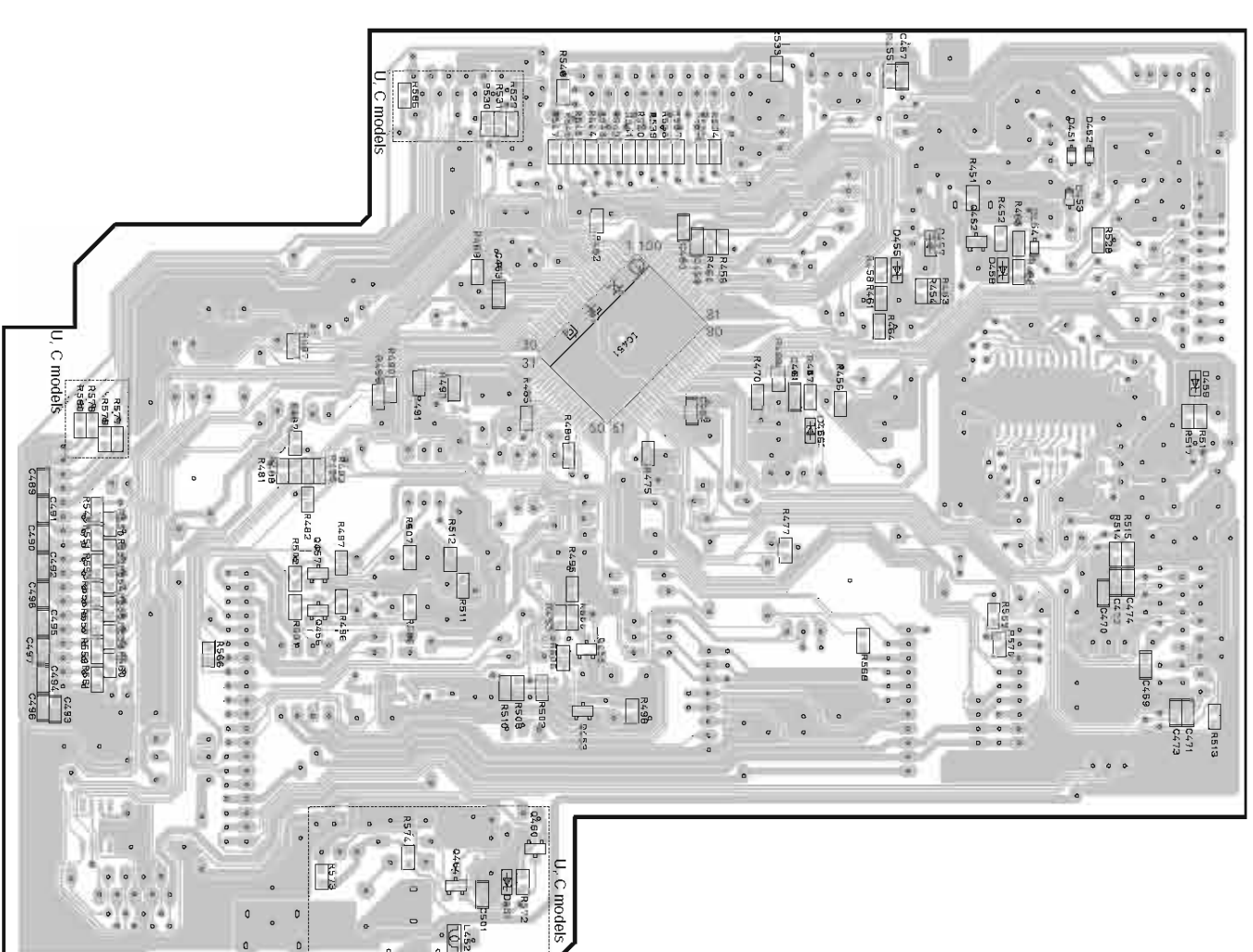
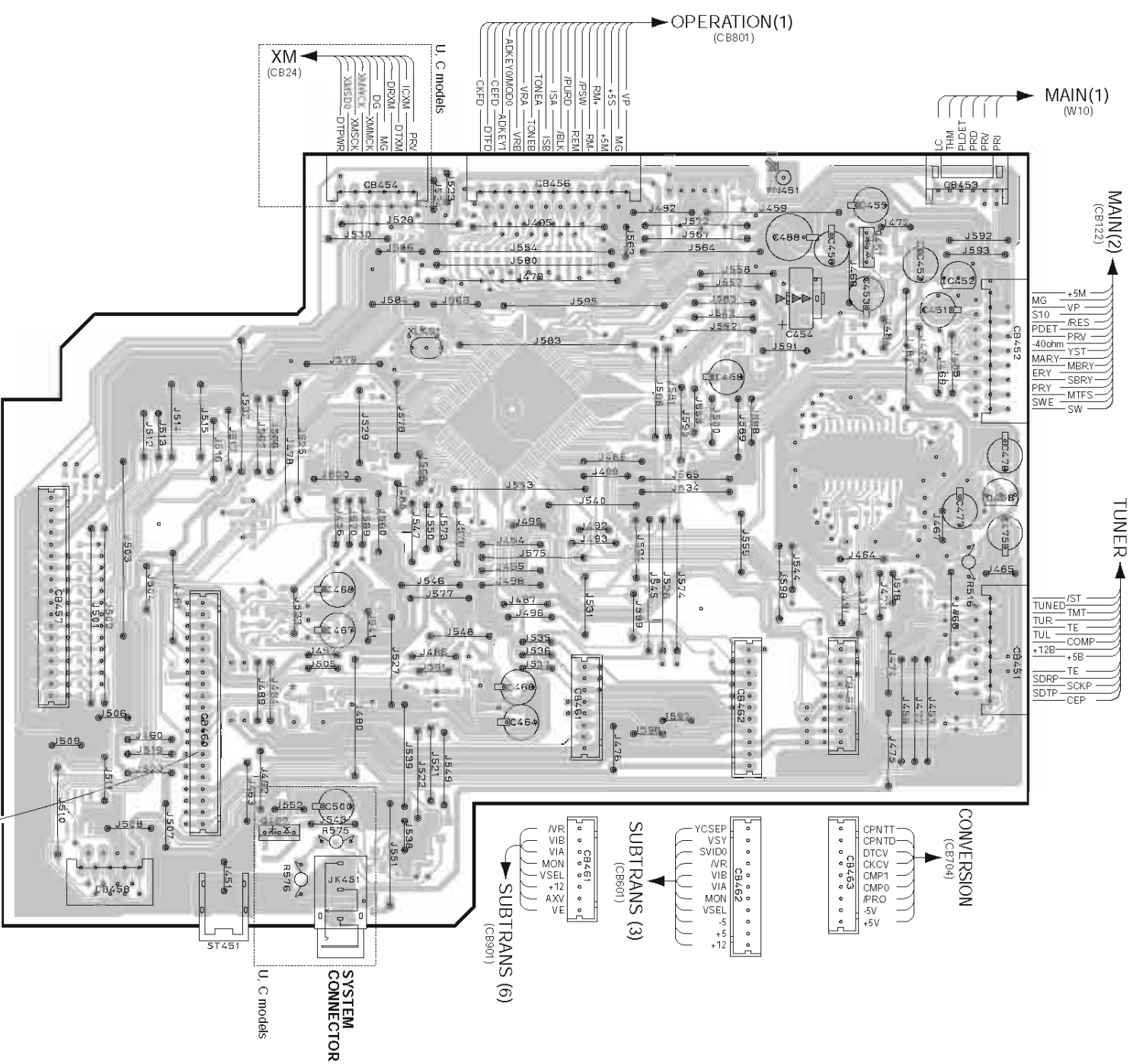

1 ■ PRINTED CIRCUIT BOARD (Foil side) **HTR-5850**

• Semiconductor Location

Ref. No.	Location
IC901	B3
Q901	C3
Q902	D3
Q903	C3
Q904	C3

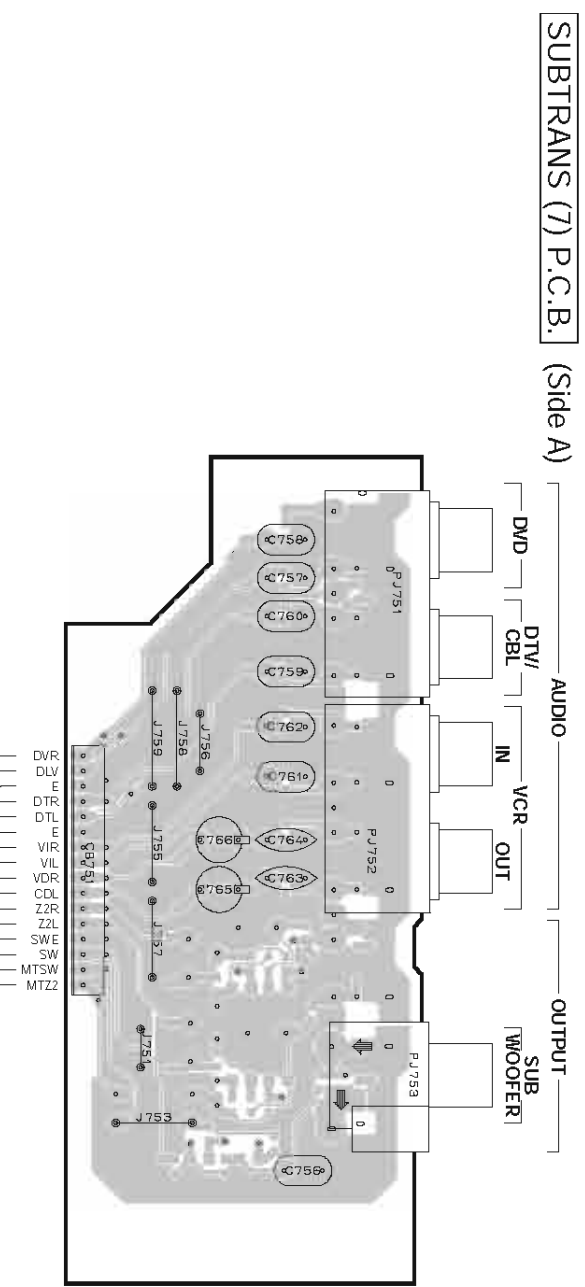
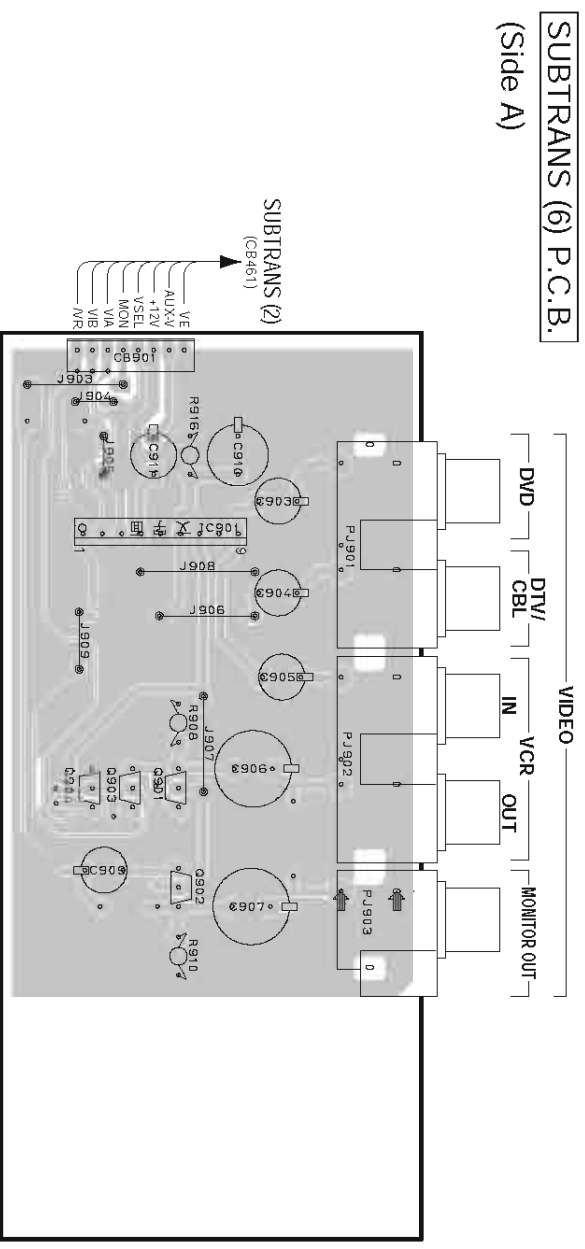

SUBTRANS (6) P.C.B. (Side B) Lead Free Solder Used

SUBTRANS (7) P.C.B. (Side B) Lead Free Solder Used

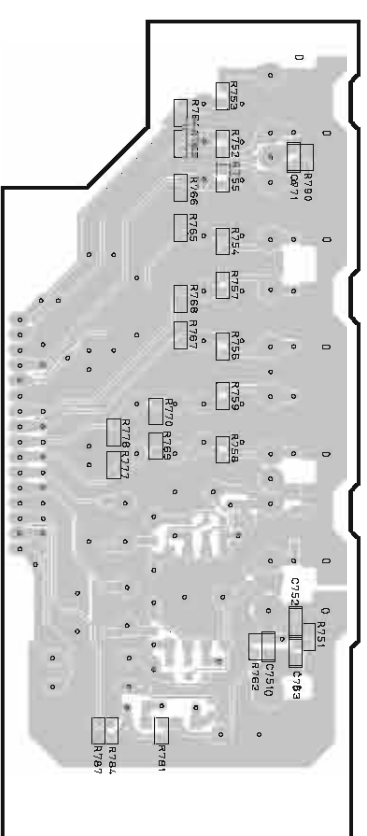
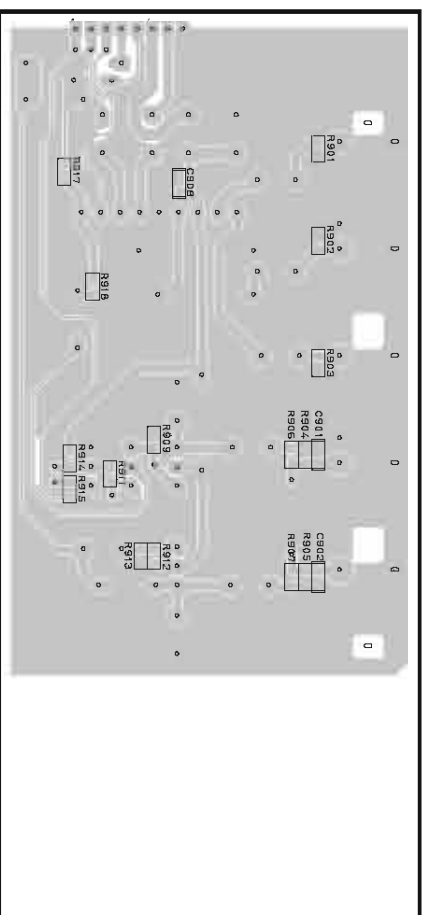

SUBTRANS (9) P.C.B. (Side A)

SUBTRANS (7) (CB751)

SUBTRANS (10) P.C.B. (Side A)

CONVERSION (CB705)

SUBTRANS (3) (CB602)

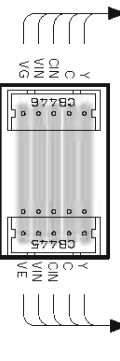
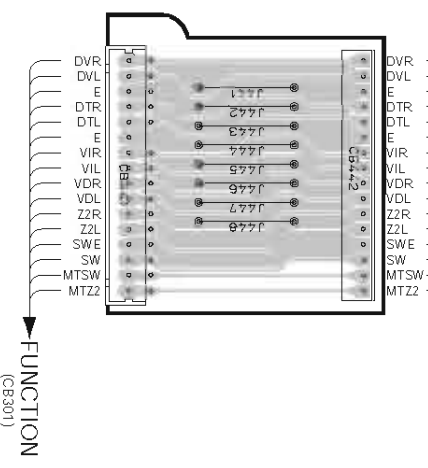

7

RX-V457/HTR-5850/DSP-AX457
RX-V457/HTR-5840/DSP-AX457

■ PRINTED CIRCUIT BOARD (Foil side) **RX-V457/HTR-5840/DSP-AX457**

SUBTRANS (1) P.C.B. (Side A)

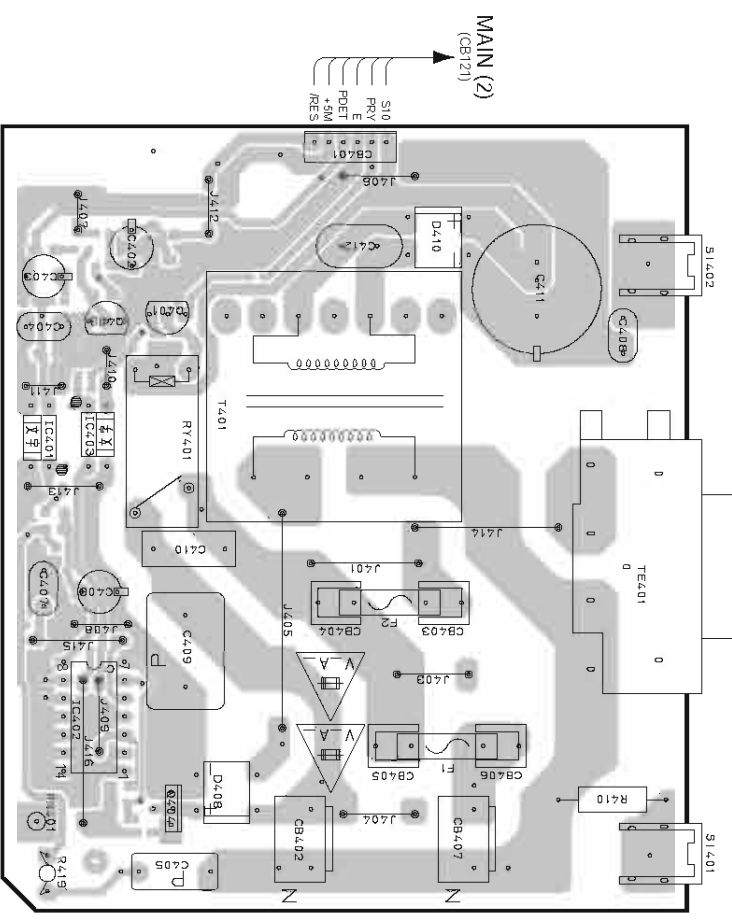

SUBTRANS (3) P.C.B. (Side A)

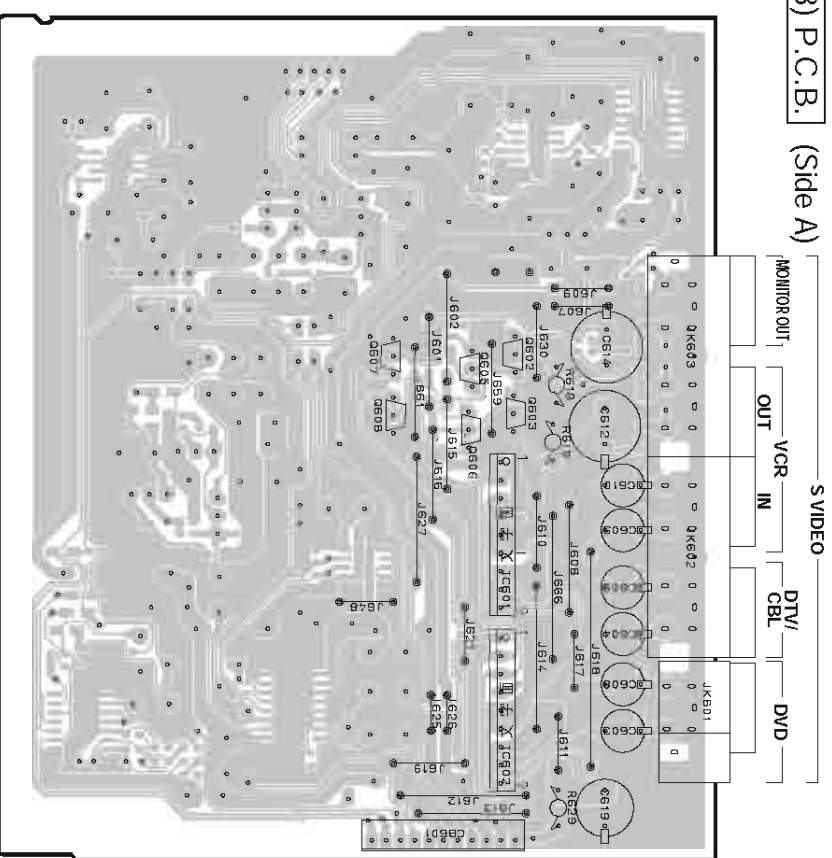

• Semiconductor Location

Ref. No.	Location
DA01	B7
DA02	B7
DA03	B7
DA04	C7
DA05	C7
DA06	C7
DA07	B6
DA09	B6
DA11	B6
DA12	C7
DA13	D7
DA14	B4
DA15	B4
DA16	B4
DA17	G2
DA18	H2
DA19	B3
DA20	B7
DA21	B4
DA22	C3
DA23	G2
DA24	G3
DA25	G3
DA26	G3
DA27	G3
DA28	G3

SUBTRANS (1) P.C.B. (Side B) Lead Free Solder Used

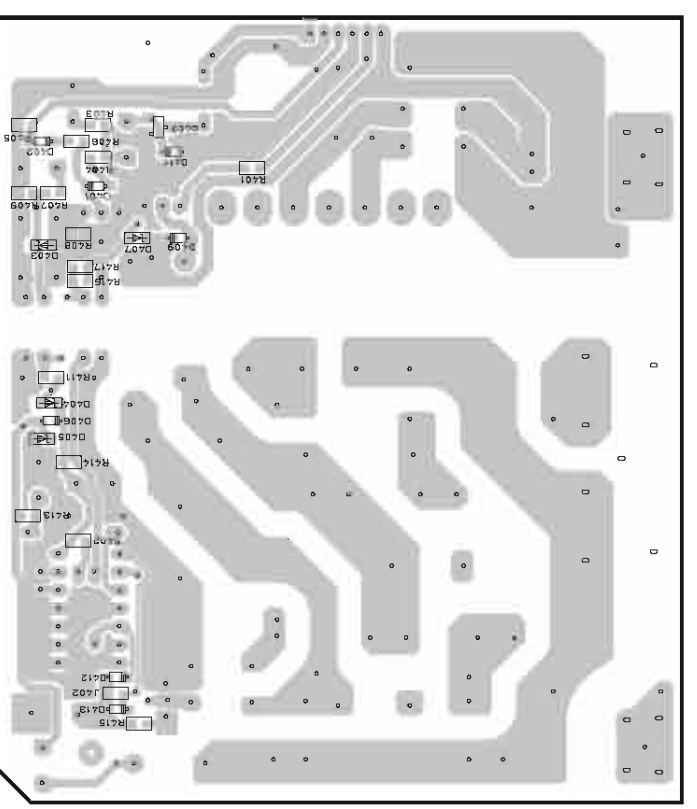

SUBTRANS (3) P.C.B. (Side B) Lead Free Solder Used

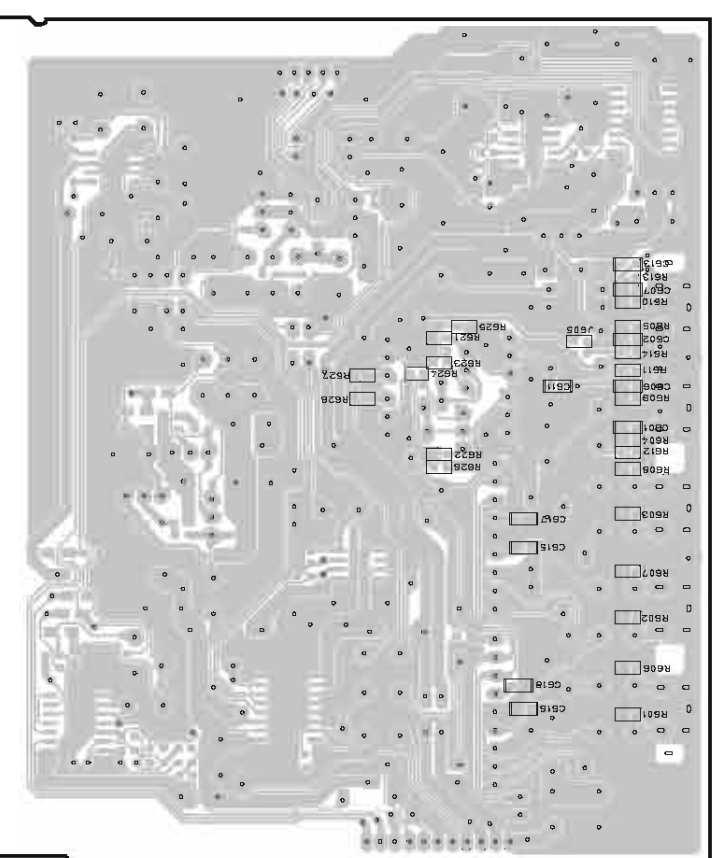

1 ■ PRINTED CIRCUIT BOARD (Foil side) **RX-V457/HTR-5840/DSP-AX457**

SUBTRANS (2) P.C.B. (Side A)

SUBTRANS (2) P.C.B. (Side B) Lead Free Solder Used

• Semiconductor Location

Ref. No.	Location
D451	F3
D452	F3
D453	G3
D454	G3
D455	G3
D456	G4
D457	G3
D458	G3
D459	G2
IC451	G4
IC452	B2
IC453	G2
Q451	B3
Q452	G3
Q453	H4
Q455	H4
Q456	H6
Q457	H6
Q458	C2
Q459	C3

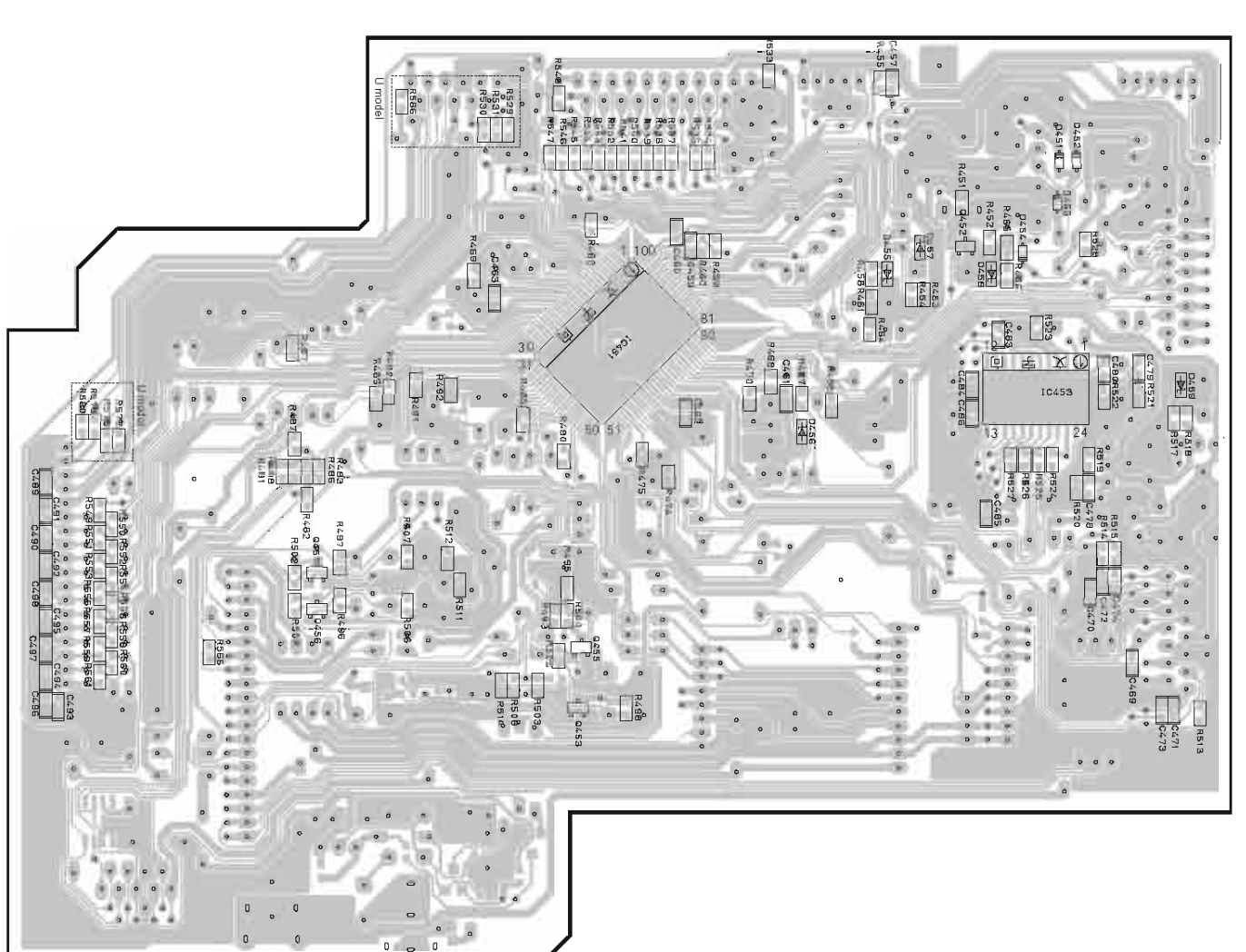
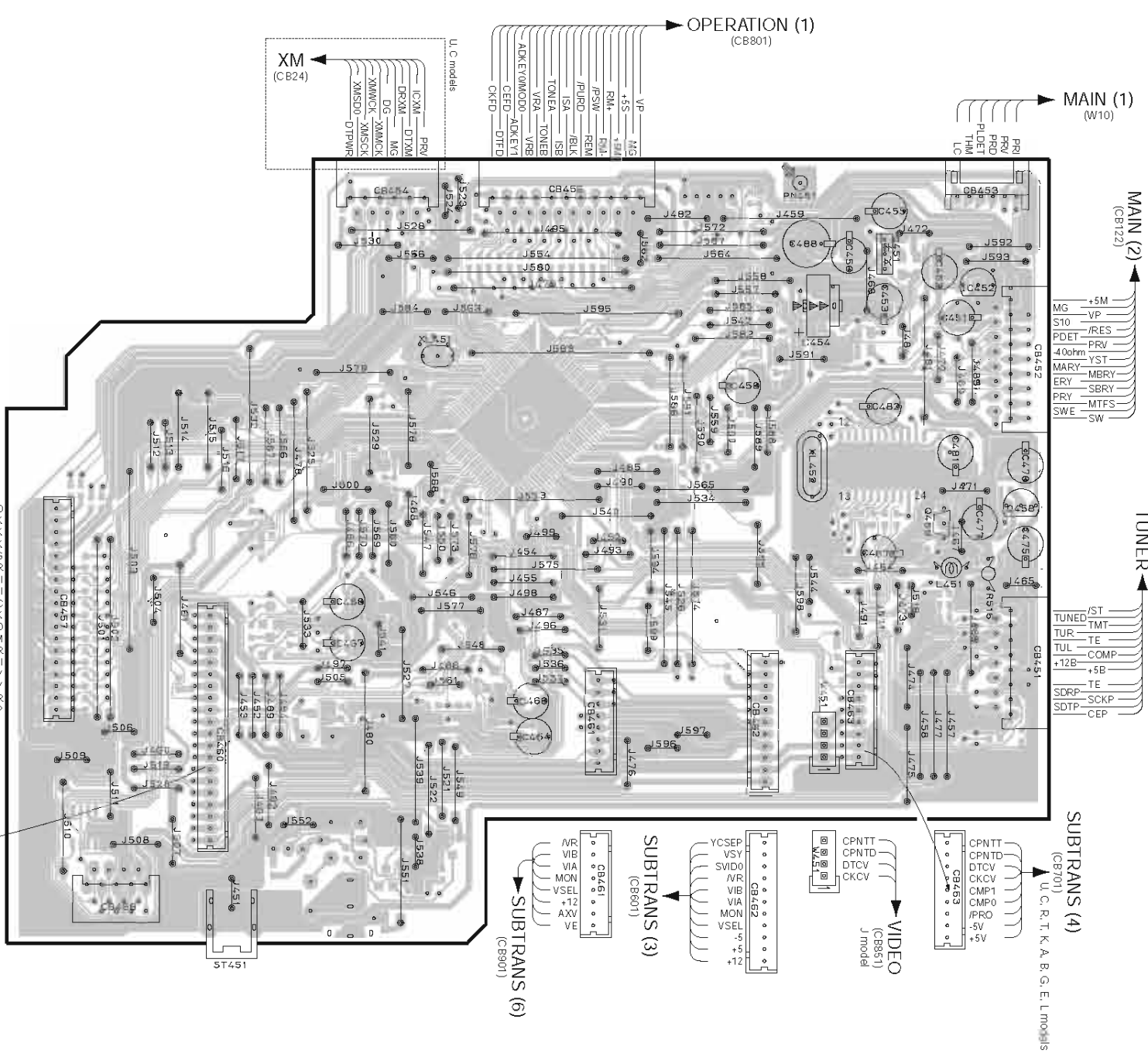

RX-V457/HTR-5840/DSP-AX457
 RX-V457/HTR-5840/DSP-AX457

PRINTED CIRCUIT BOARD (Foil side) RX-V457/HTR-5840/DSP-AX457

SUBTRANS (4) P.C.B. (Side A)

(U, C, R, T, K, A, B, G, E, L models)

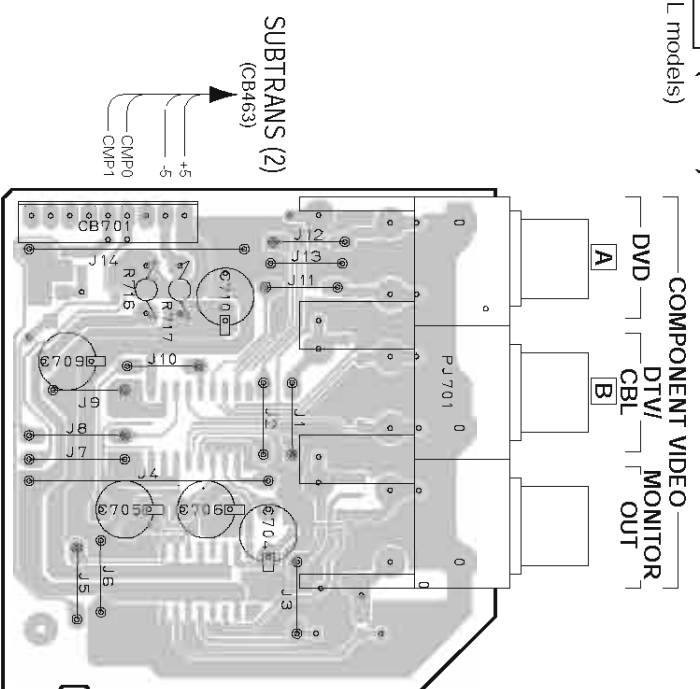

SUBTRANS (5) P.C.B. (Side A)

(R, L models)

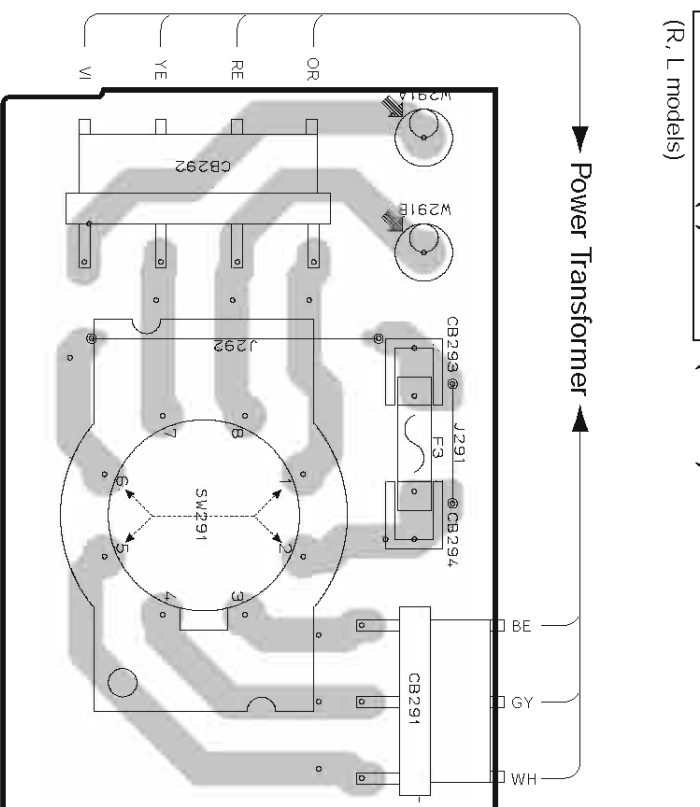

• Semiconductor Location

Ref. No.	Location
IC701	B6
IC702	C6
Q701	B6

SUBTRANS (4) P.C.B. (Side B) Lead Free Solder Used

(U, C, R, T, K, A, B, G, E, L models)

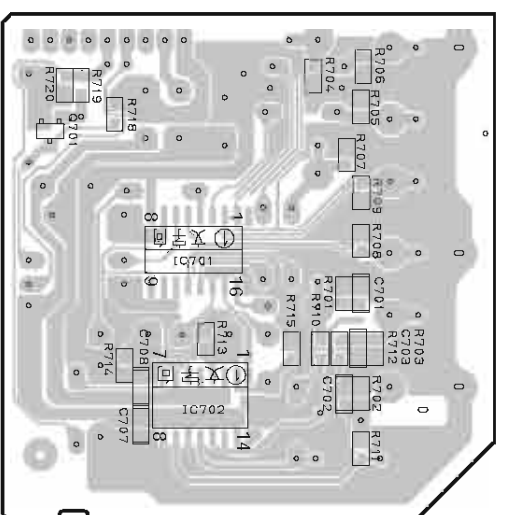

SUBTRANS (9) P.C.B. (Side A)

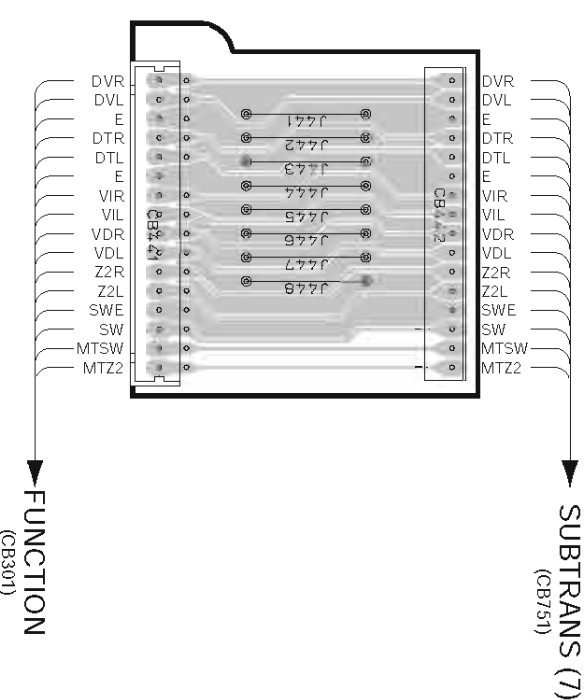

FUNCTION

1 ■ PRINTED CIRCUIT BOARD (Foil side) **RX-V457/HTR-5840/DSP-AX457**

SUBTRANS (6) P.C.B. (Side A)

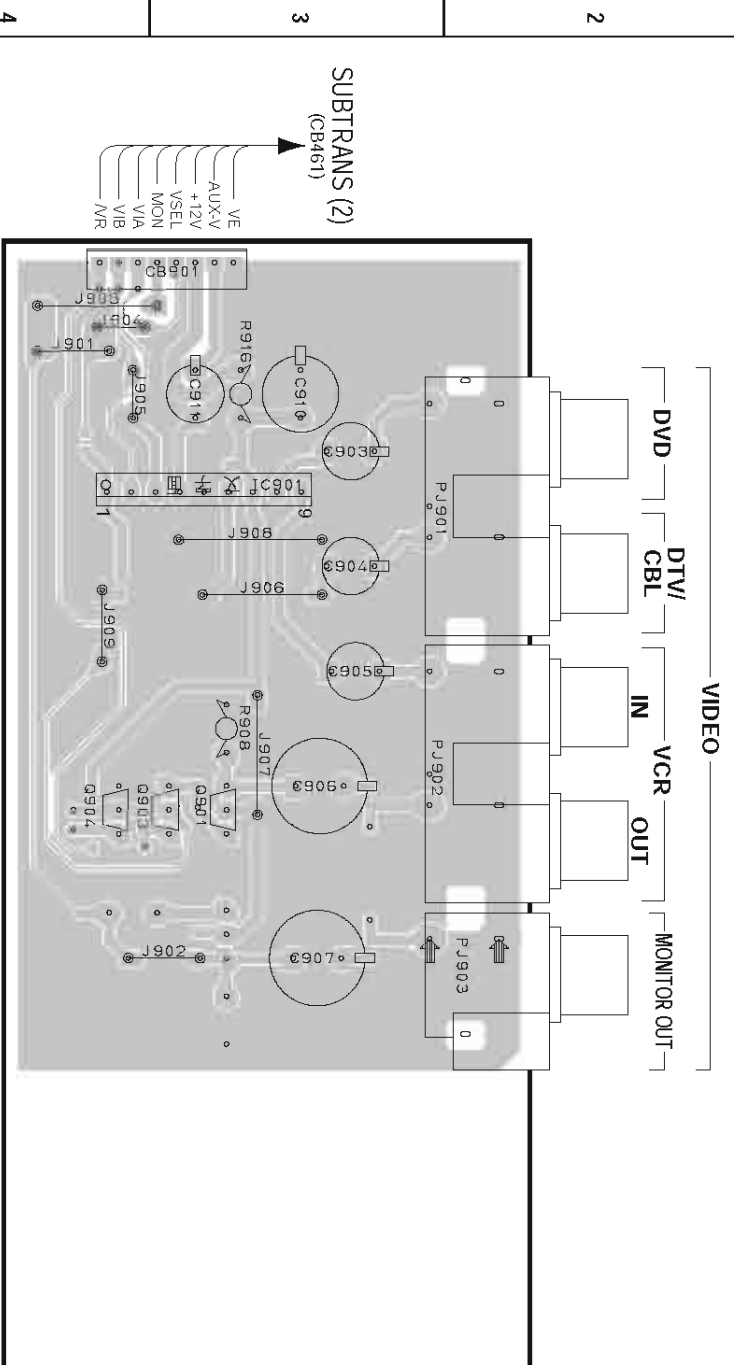

SUBTRANS (7) P.C.B. (Side A)

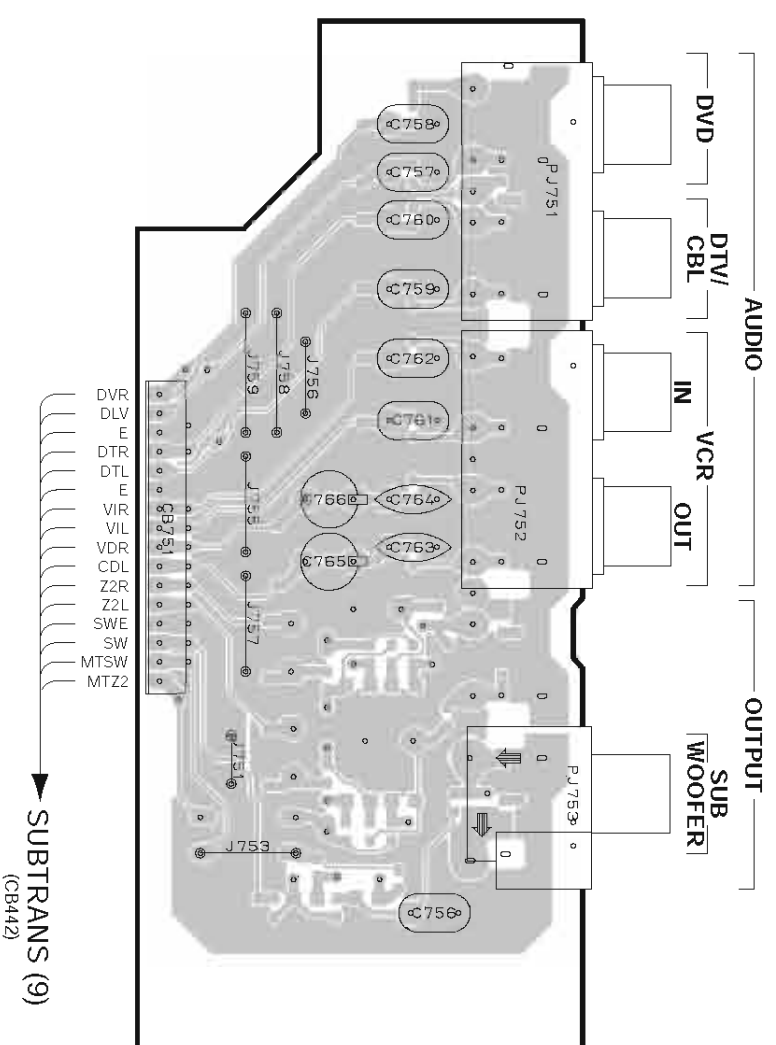

• Semiconductor Location

Ref. No.	Location
IC901	B3
O901	C3
O903	C4
O904	C4

SUBTRANS (6) P.C.B. (Side B) Lead Free Solder Used

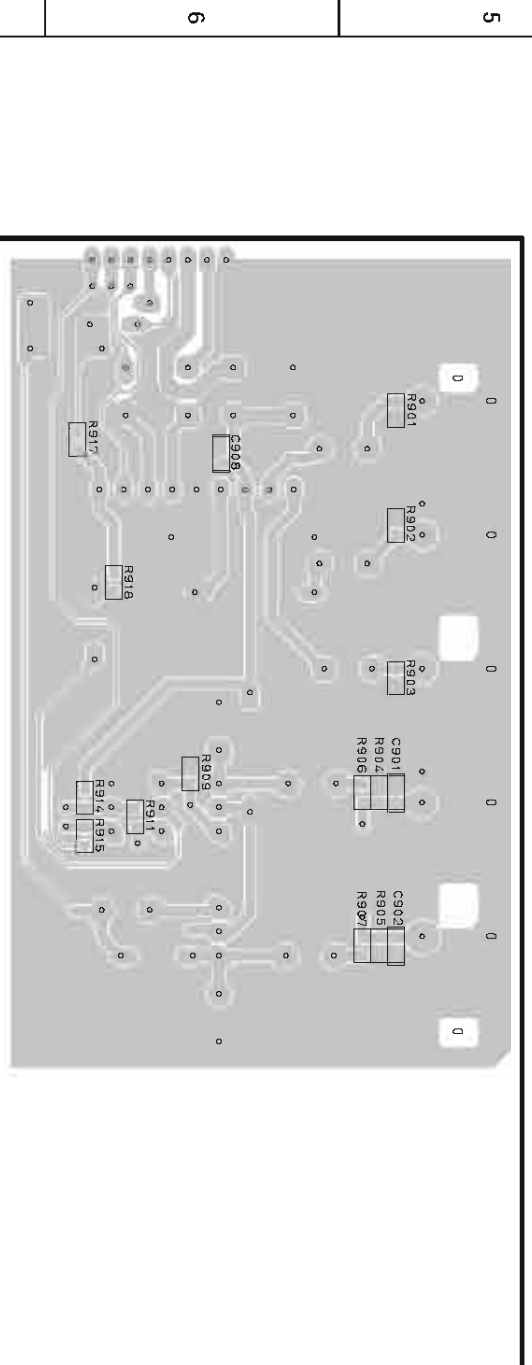

SUBTRANS (7) P.C.B. (Side B) Lead Free Solder Used

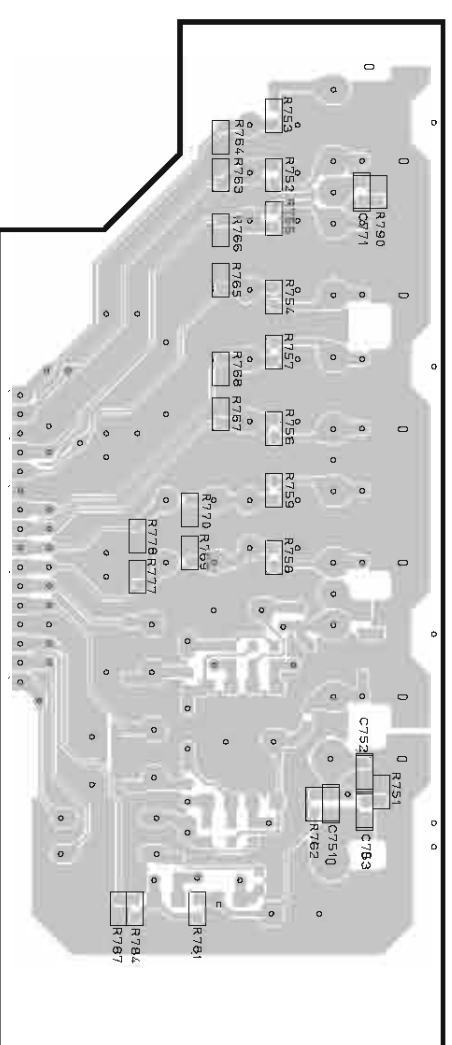

RX-V557/HTR-5850/DSP-AX557
 RX-V457/HTR-5840/DSP-AX457

PRINTED CIRCUIT BOARD (Foil side) RX-V557/HTR-5850/DSP-AX557

CONVERSION P.C.B. (Side A) Lead Solder Used

CONVERSION P.C.B. (Side B) Lead Free Solder Used

• Semiconductor Location

Ref. No.	Location
D702	B3
D703	B3
D705	C3
D706	C3
D707	D3
D708	I3
D709	D3
D710	I3
D711	D3
D712	D3
IC701	C3
IC702	D3
IC703	D3
IC704	D3
IC705	D5
IC706	B3
IC707	B3
IC708	D5
IC709	C4
IC710	B4
IC711	C4
IC712	B5
IC713	C5
IC714	C5
Q702	I4
Q703	I5
Q704	I4
Q705	H4
Q706	I4
Q707	H4
Q708	I5
Q709	H5
Q710	I5
Q711	H5
Q712	B4
Q713	G4
Q714	G4

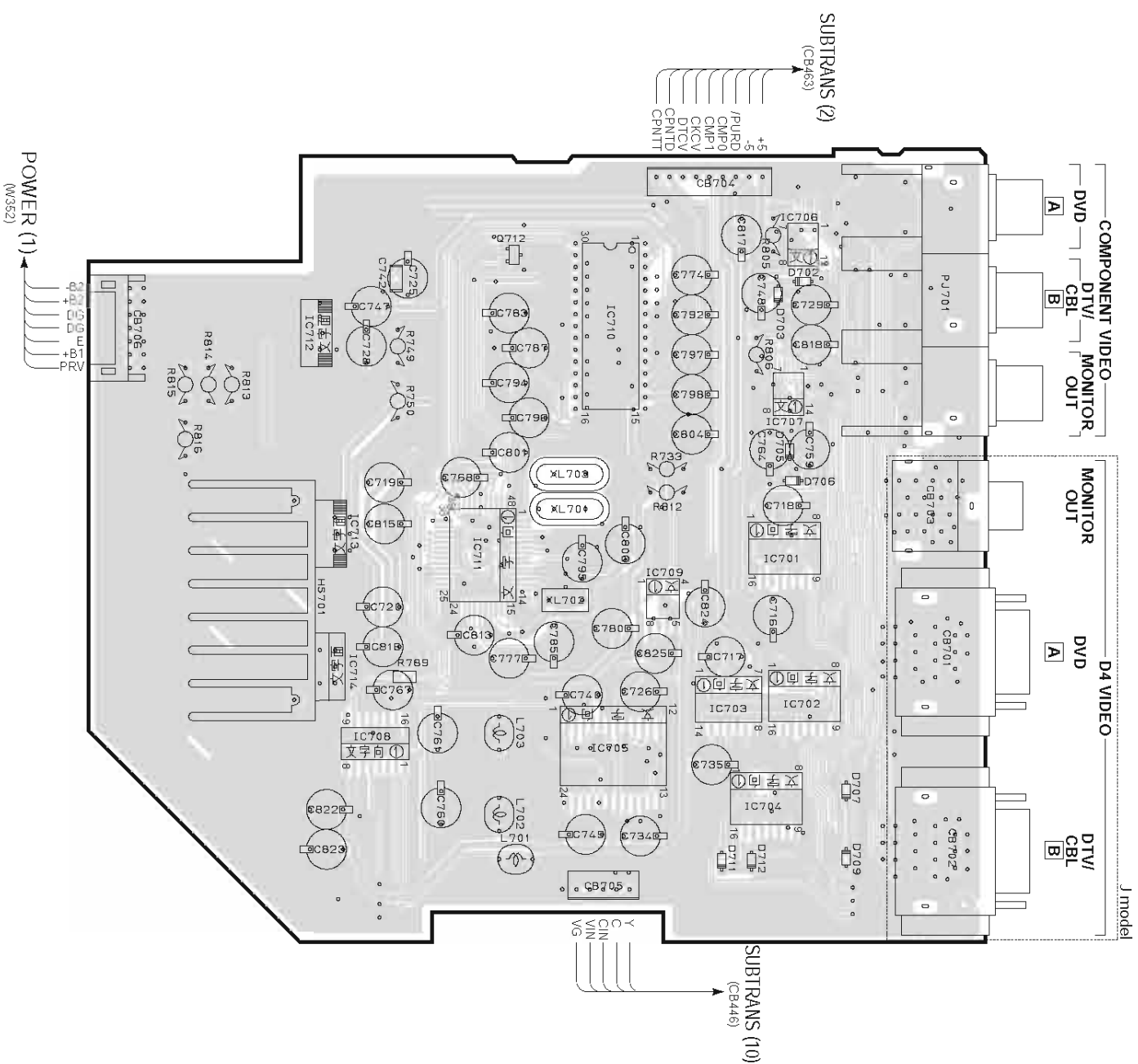

Circuit No.	J	U.C.	K	R	I	A	B	G	E	L
CEB701-703	X	X	X	X	X	X	X	X	X	X
C717, 714, 783, 787, 792, 794, 796, 798, 801, 804	X	X	X	X	X	X	X	X	X	X
D707-712	X	X	X	X	X	X	X	X	X	X
IC704	X	X	X	X	X	X	X	X	X	X
IC710	X	X	X	X	X	X	X	X	X	X
Q713, 714	X	X	X	X	X	X	X	X	X	X
R749	X	X	X	X	X	X	X	X	X	X
XL703	X	X	X	X	X	X	X	X	X	X

X NOTUSED / O USED

1 ■ PRINTED CIRCUIT BOARD (Foil side) **DSP-AX457**

VIDEO P.C.B. (Side A)

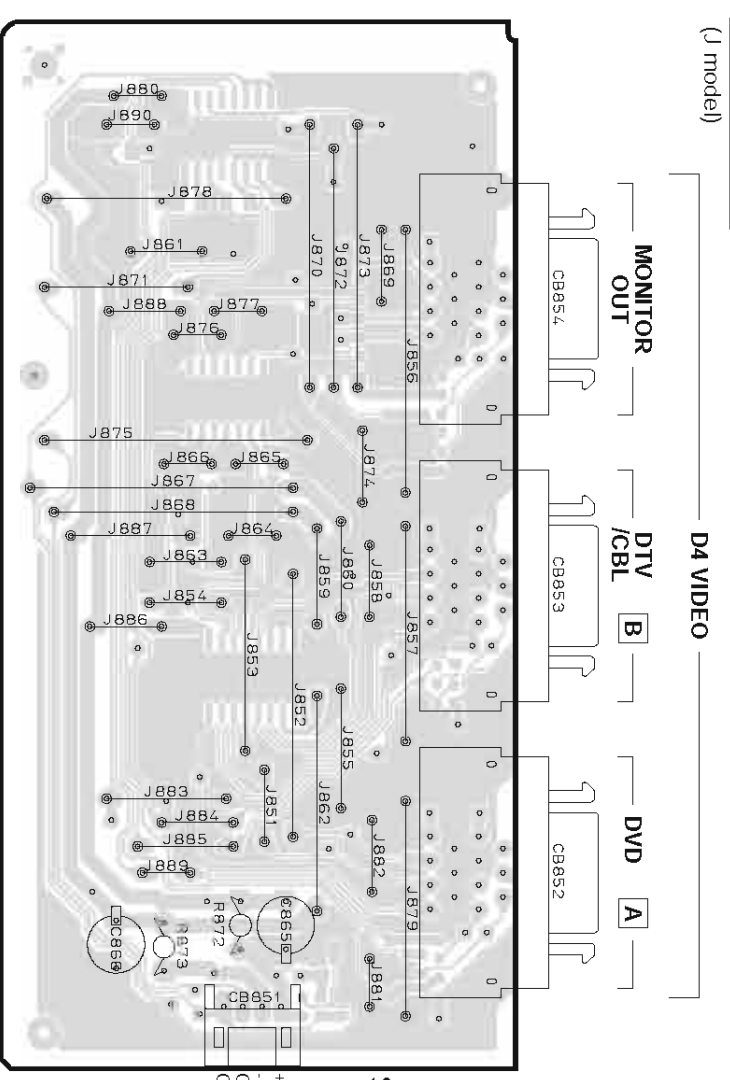

D4 VIDEO

MONITOR OUT

DTV /CBL

DVD

SUBTRANS (2)
(M451)
+5V
-5V
CMP0
CMP1

• Semiconductor Location

Ref. No.	Location
D851	A7
D852	A6
D853	A6
D854	A7
D855	A6
D856	A6
D857	B7
IC851	C6
IC852	A6
IC853	B6
Q851	D6

■ **RX-V557/HTR-5850** **RX-V457/HTR-5840**

XM P.C.B. (Side A) Lead Solder Used

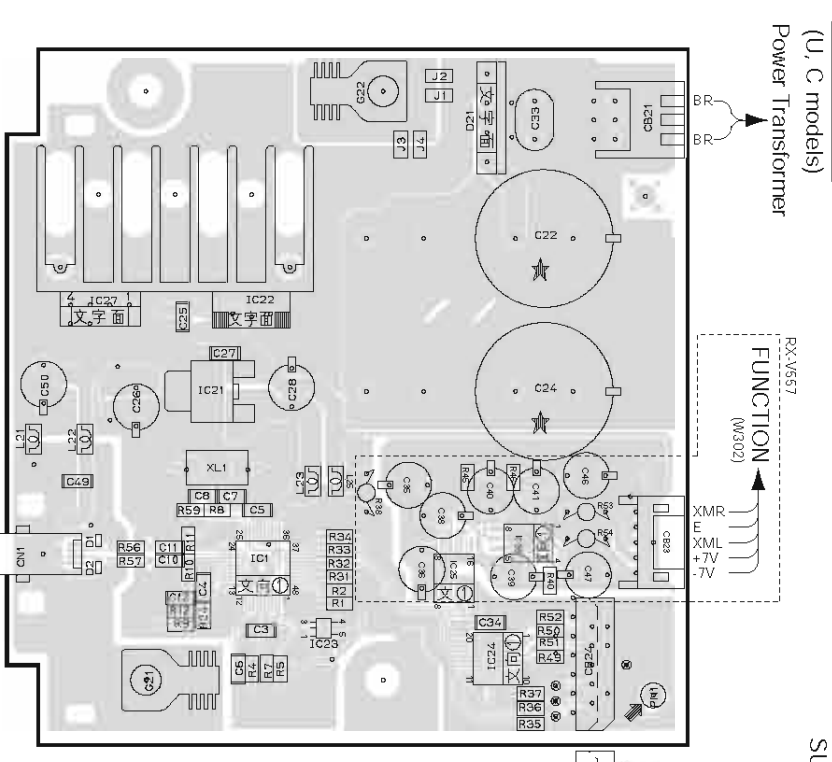

Power Transformer

FUNCTION (W302)

SUBTRANS (2)
(C8454)

XMPWR
XMSCK
XMSDO
XMMXCK
XMWCK
DG
MC
DRXM
DTXM
ICXM
PRV

• Semiconductor Location

Ref. No.	Location
D1	H4
D2	H4
D21	F3
D26	G7
IC1	H3
IC21	G3
IC22	G3
IC23	H3
IC24	H3
IC25	H3
IC26	H2
IC27	G4

VIDEO P.C.B. (Side A) Lead Free Solder Used
(U model)

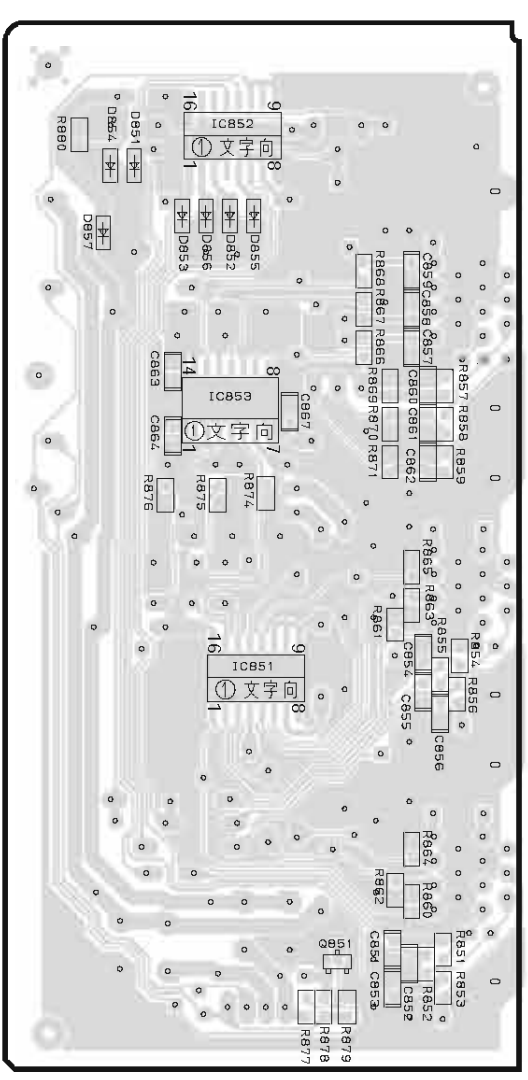

XM P.C.B. (Side B) Lead Free Solder Used
(U, C models)



■ PIN CONNECTION DIAGRAM

• ICS

LM61CIZ 	NUJ7201L55 	NJM7805FA NJM7809FA NJM7812FA 	NJM79M05FA NJM79M12FA 	μPC29M33TE1 	PO012FZ01ZP 	NJM2388F
NE5532DR 	SN74AHC1G08DCKR SN74AHC1G32DCKR 	NJM2068MD TK15420M 	NJM2581M SN74AHC100PW SN74AHC108PW SN74LV157APWR SN74LV004APWR 	PQ05RD11 	NJM78M05D11A 	BA50BC0T
NJM4556AL 	LA7956 	TC74HCU04AFEL TC4013BP 	TC74VHCU04FT 	TC74HC4052AF TC74HC4053AF 	SN74LV245APWR 	
AK4384ET 	TC90A49F 	LC72722PM 	BD3841FS 	TA8772AN 		
MEM29LV400BC-70PFT 	TA11270BF 	AK4628VQ 	BD3818K1 			
XMDT 	W9816G6CH 	LC89057WVF4D-E 	M66003-0131FP 			

• Diodes

1N4002S 1SS133 1SS270A 1T2 	MTZJ15A MTZJ2.4B MTZJ27A MTZJ30A 	1SS355 MA8030-L MA8051-M MA8056-M MA8068-H MA8075-H MA8091-M MA8100-M RB500V-40 UDZ3.6BTE-17 	SB01-05Q
TS6P03G 	D3SBA20 KBP103G 		STNB20 STNB60

• Transistors

2SA1015 2SA949 2SC1815 2SC1890A 2SC2229 2SC2240 2SC535 2SA2M5401C 2SC2N5551C 	2SC1740S 2SD1915F 	2SB1274 	2SA1695 2SC4468
2SA1037K 2SC2412K 2SD1938F DT1C144EKA 	2SA1770 2SA1770 2SC4488 2SC4614 		

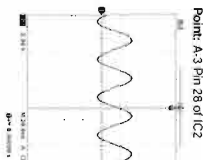
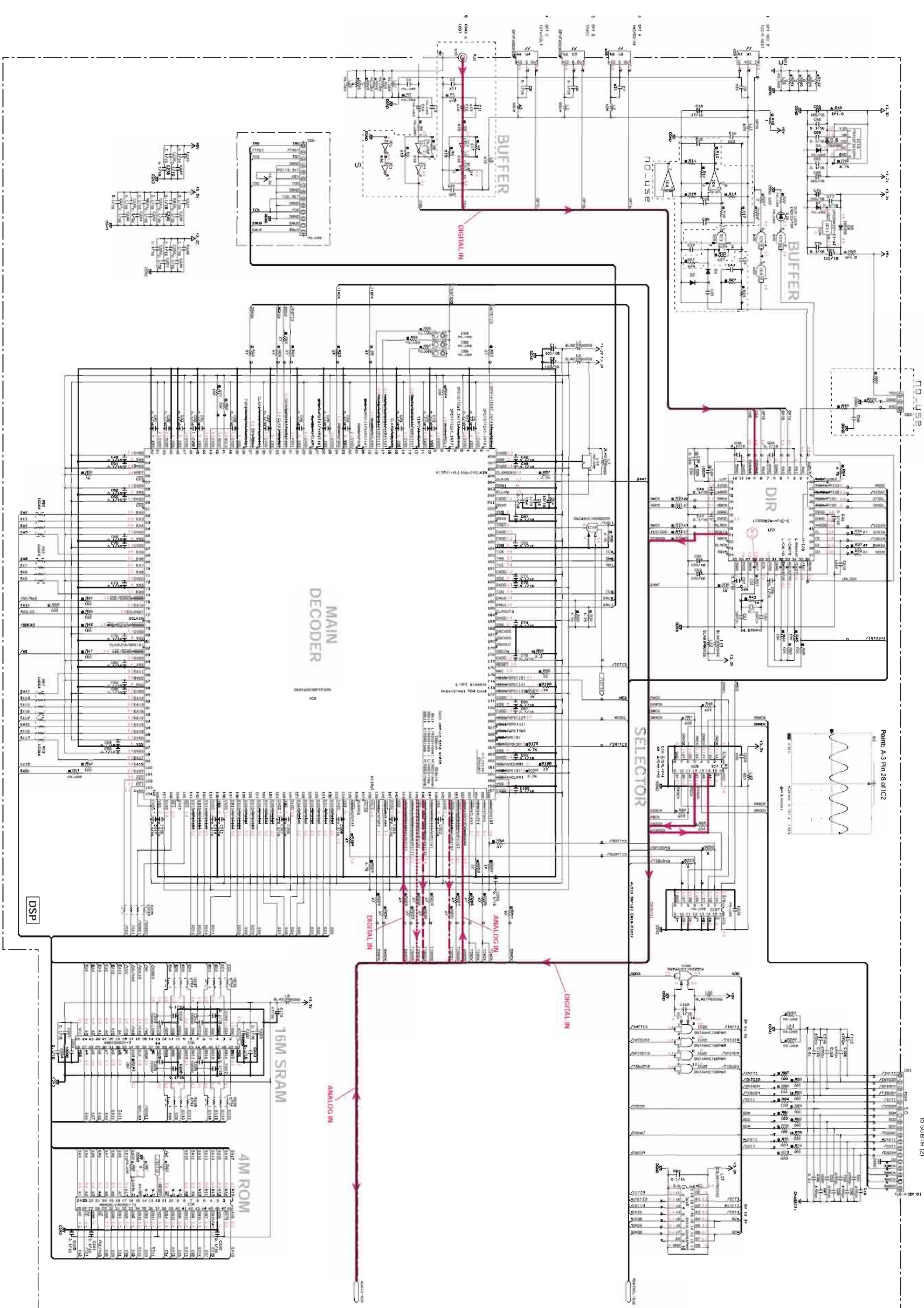

RX-V551DSP-AX551 Page 88
 HTR-5850 Page 89
 RX-V451HTR-584QDSP-AX451 Page 90
 10 SUBSTR (2)

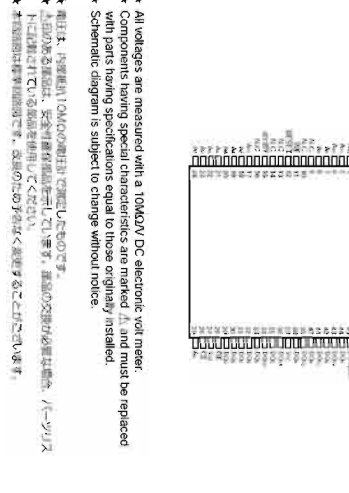
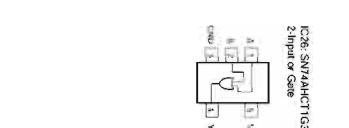
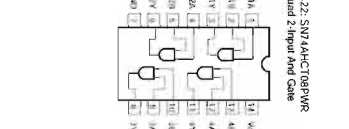
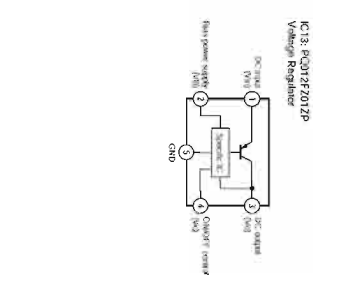
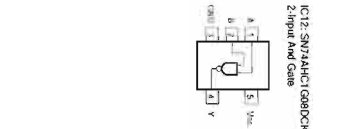
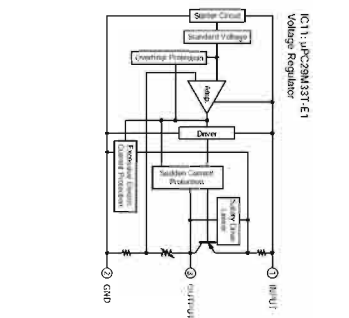
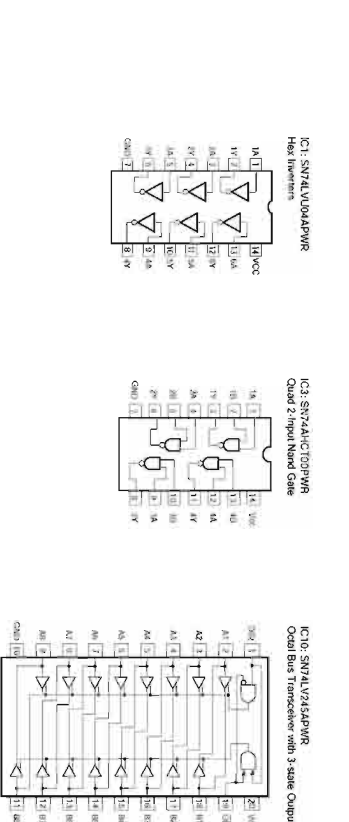
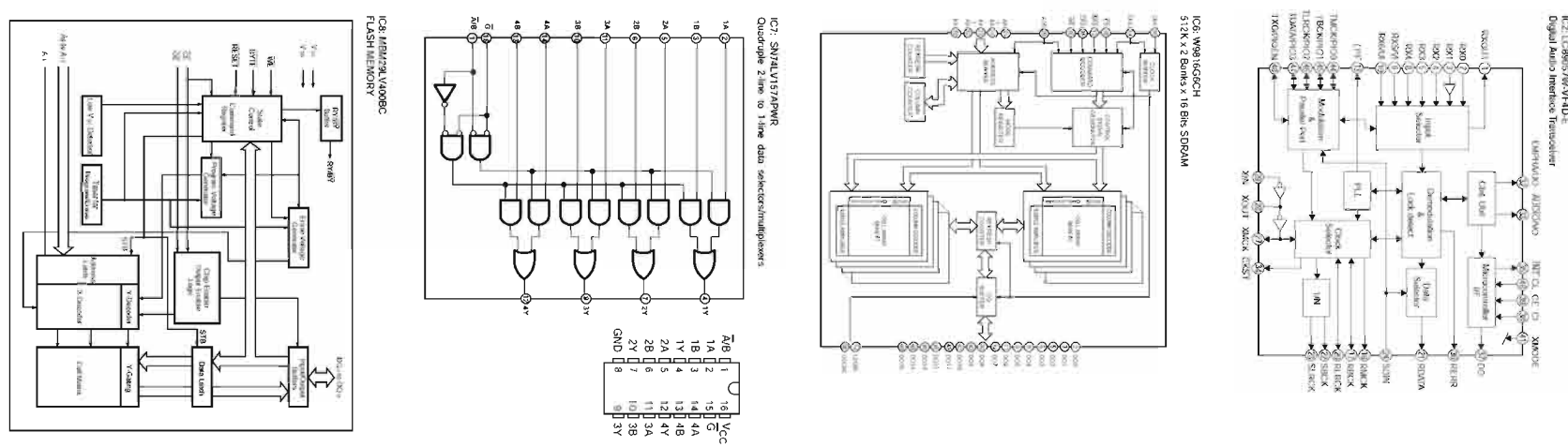

IC3: ANALYZADAPPR
 Quad 2 Input NAND Gate

IC4: 16B79LV480BC
 FLASH MEMORY

IC5: ANALYZADAPPR
 Quad 2 Input NAND Gate

IC6: ANALYZADAPPR
 Quad 2 Input NAND Gate

IC7: ANALYZADAPPR
 Quad 2 Input NAND Gate

IC8: ANALYZADAPPR
 Quad 2 Input NAND Gate

IC9: ANALYZADAPPR
 Quad 2 Input NAND Gate

IC10: ANALYZADAPPR
 Quad 2 Input NAND Gate

IC11: UC1825B1-E1
 Voltage Regulator

IC12: SN74ALS160B0CR
 2 Input And Gate

IC13: PD172P01P
 Voltage Regulator

IC14: ANALYZADAPPR
 Quad 2 Input NAND Gate

IC15: ANALYZADAPPR
 Quad 2 Input NAND Gate

IC16: ANALYZADAPPR
 Quad 2 Input NAND Gate

IC17: ANALYZADAPPR
 Quad 2 Input NAND Gate

IC18: ANALYZADAPPR
 Quad 2 Input NAND Gate

IC19: ANALYZADAPPR
 Quad 2 Input NAND Gate

IC20: ANALYZADAPPR
 Quad 2 Input NAND Gate

IC21: ANALYZADAPPR
 Quad 2 Input NAND Gate

IC22: SN74ALS16B0CR
 Quad 2 Input And Gate

IC23: ANALYZADAPPR
 Quad 2 Input NAND Gate

IC24: ANALYZADAPPR
 Quad 2 Input NAND Gate

IC25: ANALYZADAPPR
 Quad 2 Input NAND Gate

IC26: SN74ALS1630CR
 2 Input And Gate

IC27: ANALYZADAPPR
 Quad 2 Input NAND Gate

IC28: ANALYZADAPPR
 Quad 2 Input NAND Gate

IC29: ANALYZADAPPR
 Quad 2 Input NAND Gate

IC30: ANALYZADAPPR
 Quad 2 Input NAND Gate

IC31: ANALYZADAPPR
 Quad 2 Input NAND Gate

IC32: ANALYZADAPPR
 Quad 2 Input NAND Gate

IC33: ANALYZADAPPR
 Quad 2 Input NAND Gate

IC34: ANALYZADAPPR
 Quad 2 Input NAND Gate

IC35: ANALYZADAPPR
 Quad 2 Input NAND Gate

IC36: ANALYZADAPPR
 Quad 2 Input NAND Gate

IC37: ANALYZADAPPR
 Quad 2 Input NAND Gate

IC38: ANALYZADAPPR
 Quad 2 Input NAND Gate

IC39: ANALYZADAPPR
 Quad 2 Input NAND Gate

IC40: ANALYZADAPPR
 Quad 2 Input NAND Gate

IC41: ANALYZADAPPR
 Quad 2 Input NAND Gate

IC42: ANALYZADAPPR
 Quad 2 Input NAND Gate

IC43: ANALYZADAPPR
 Quad 2 Input NAND Gate

IC44: ANALYZADAPPR
 Quad 2 Input NAND Gate

IC45: ANALYZADAPPR
 Quad 2 Input NAND Gate

IC46: ANALYZADAPPR
 Quad 2 Input NAND Gate

IC47: ANALYZADAPPR
 Quad 2 Input NAND Gate

IC48: ANALYZADAPPR
 Quad 2 Input NAND Gate

IC49: ANALYZADAPPR
 Quad 2 Input NAND Gate

IC50: ANALYZADAPPR
 Quad 2 Input NAND Gate

IC51: ANALYZADAPPR
 Quad 2 Input NAND Gate

IC52: ANALYZADAPPR
 Quad 2 Input NAND Gate

IC53: ANALYZADAPPR
 Quad 2 Input NAND Gate

IC54: ANALYZADAPPR
 Quad 2 Input NAND Gate

IC55: ANALYZADAPPR
 Quad 2 Input NAND Gate

IC56: ANALYZADAPPR
 Quad 2 Input NAND Gate

IC57: ANALYZADAPPR
 Quad 2 Input NAND Gate

IC58: ANALYZADAPPR
 Quad 2 Input NAND Gate

IC59: ANALYZADAPPR
 Quad 2 Input NAND Gate

IC60: ANALYZADAPPR
 Quad 2 Input NAND Gate

IC61: ANALYZADAPPR
 Quad 2 Input NAND Gate

IC62: ANALYZADAPPR
 Quad 2 Input NAND Gate

IC63: ANALYZADAPPR
 Quad 2 Input NAND Gate

IC64: ANALYZADAPPR
 Quad 2 Input NAND Gate

IC65: ANALYZADAPPR
 Quad 2 Input NAND Gate

IC66: ANALYZADAPPR
 Quad 2 Input NAND Gate

IC67: ANALYZADAPPR
 Quad 2 Input NAND Gate

IC68: ANALYZADAPPR
 Quad 2 Input NAND Gate

IC69: ANALYZADAPPR
 Quad 2 Input NAND Gate

IC70: ANALYZADAPPR
 Quad 2 Input NAND Gate

IC71: ANALYZADAPPR
 Quad 2 Input NAND Gate

IC72: ANALYZADAPPR
 Quad 2 Input NAND Gate

IC73: ANALYZADAPPR
 Quad 2 Input NAND Gate

IC74: ANALYZADAPPR
 Quad 2 Input NAND Gate

IC75: ANALYZADAPPR
 Quad 2 Input NAND Gate

IC76: ANALYZADAPPR
 Quad 2 Input NAND Gate

IC77: ANALYZADAPPR
 Quad 2 Input NAND Gate

IC78: ANALYZADAPPR
 Quad 2 Input NAND Gate

IC79: ANALYZADAPPR
 Quad 2 Input NAND Gate

IC80: ANALYZADAPPR
 Quad 2 Input NAND Gate

IC81: ANALYZADAPPR
 Quad 2 Input NAND Gate

IC82: ANALYZADAPPR
 Quad 2 Input NAND Gate

IC83: ANALYZADAPPR
 Quad 2 Input NAND Gate

IC84: ANALYZADAPPR
 Quad 2 Input NAND Gate

IC85: ANALYZADAPPR
 Quad 2 Input NAND Gate

IC86: ANALYZADAPPR
 Quad 2 Input NAND Gate

IC87: ANALYZADAPPR
 Quad 2 Input NAND Gate

IC88: ANALYZADAPPR
 Quad 2 Input NAND Gate

IC89: ANALYZADAPPR
 Quad 2 Input NAND Gate

IC90: ANALYZADAPPR
 Quad 2 Input NAND Gate

IC91: ANALYZADAPPR
 Quad 2 Input NAND Gate

IC92: ANALYZADAPPR
 Quad 2 Input NAND Gate

IC93: ANALYZADAPPR
 Quad 2 Input NAND Gate

IC94: ANALYZADAPPR
 Quad 2 Input NAND Gate

IC95: ANALYZADAPPR
 Quad 2 Input NAND Gate

IC96: ANALYZADAPPR
 Quad 2 Input NAND Gate

IC97: ANALYZADAPPR
 Quad 2 Input NAND Gate

IC98: ANALYZADAPPR
 Quad 2 Input NAND Gate

IC99: ANALYZADAPPR
 Quad 2 Input NAND Gate

IC100: ANALYZADAPPR
 Quad 2 Input NAND Gate

All voltages are measured with a 10MΩV DC electronic volt meter.
 Components having special characteristics are marked 'A' and must be replaced with parts having specifications equal to those originally installed.
 Schematic diagram is subject to change without notice.
 * 組立時、内蔵抵抗10MΩの電圧降下を避けるために、必ずしも必要ではありません。但し、必ずしも必要ではありません。
 * 組立時、必ずしも必要ではありません。必ずしも必要ではありません。
 * 組立時、必ずしも必要ではありません。必ずしも必要ではありません。

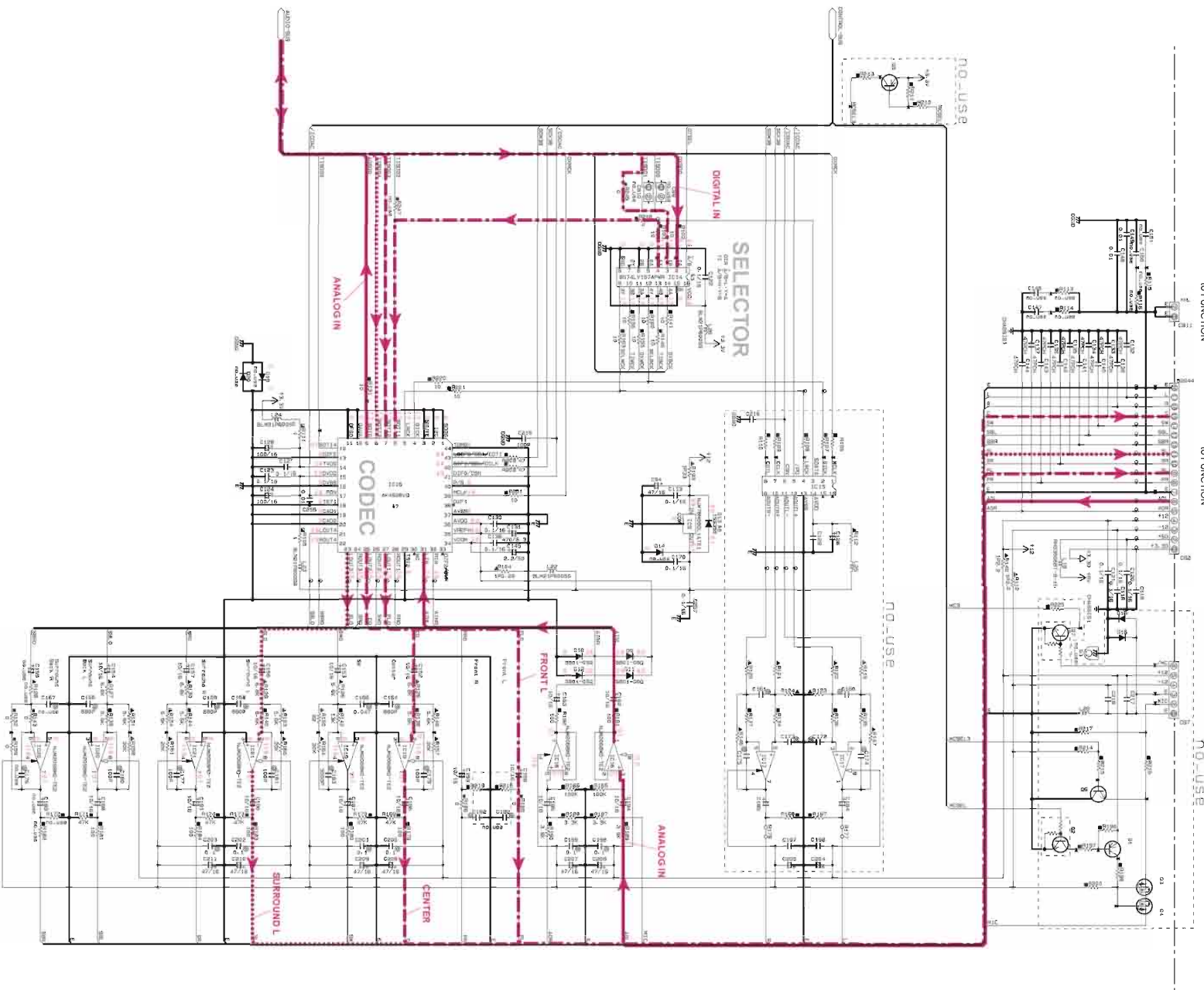

RESISTOR	VALUE	UNIT	RESISTOR	VALUE	UNIT	RESISTOR	VALUE	UNIT
R1	10K	Ω	R10	10K	Ω	R19	10K	Ω
R2	10K	Ω	R11	10K	Ω	R20	10K	Ω
R3	10K	Ω	R12	10K	Ω	R21	10K	Ω
R4	10K	Ω	R13	10K	Ω	R22	10K	Ω
R5	10K	Ω	R14	10K	Ω	R23	10K	Ω
R6	10K	Ω	R15	10K	Ω	R24	10K	Ω
R7	10K	Ω	R16	10K	Ω	R25	10K	Ω
R8	10K	Ω	R17	10K	Ω	R26	10K	Ω
R9	10K	Ω	R18	10K	Ω	R27	10K	Ω

RESISTOR	VALUE	UNIT	RESISTOR	VALUE	UNIT
R28	10K	Ω	R35	10K	Ω
R29	10K	Ω	R36	10K	Ω
R30	10K	Ω	R37	10K	Ω
R31	10K	Ω	R38	10K	Ω
R32	10K	Ω	R39	10K	Ω
R33	10K	Ω	R40	10K	Ω
R34	10K	Ω	R41	10K	Ω

RESISTOR	VALUE	UNIT	RESISTOR	VALUE	UNIT
R42	10K	Ω	R49	10K	Ω
R43	10K	Ω	R50	10K	Ω
R44	10K	Ω	R51	10K	Ω
R45	10K	Ω	R52	10K	Ω
R46	10K	Ω	R53	10K	Ω
R47	10K	Ω	R54	10K	Ω
R48	10K	Ω	R55	10K	Ω

NOTICE (mm)

(U)..... U.S.A.
 (J)..... JAPAN
 (E)..... EUROPE
 (O)..... OTHER

(1)..... CHINA
 (K)..... KOREA
 (S)..... SINGAPORE
 (B)..... BRITISH
 (I)..... INDIA
 (V)..... SOUTH AFRICA
 (T)..... TAIWAN

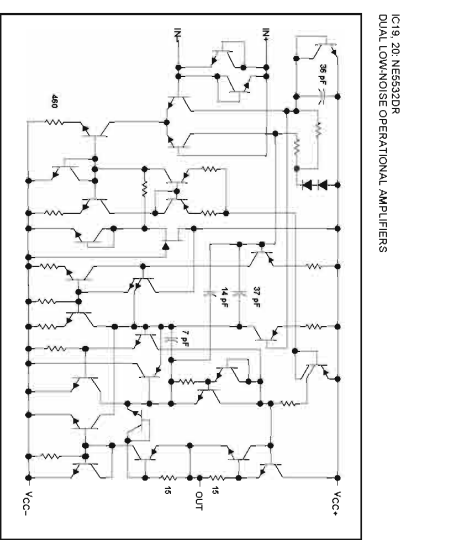
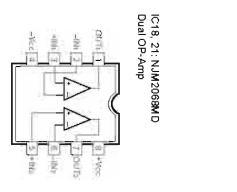
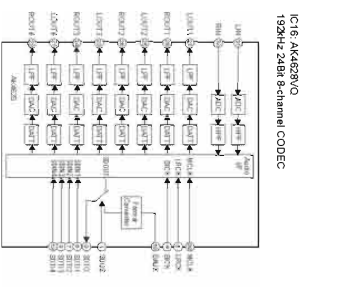
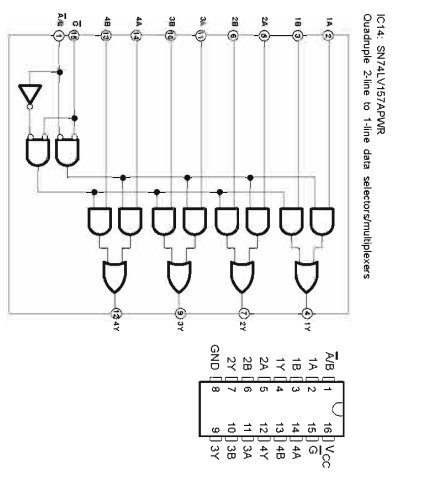
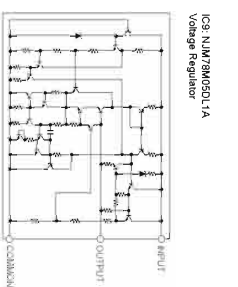

* All voltages are measured with a 10MΩV DC electronic volt meter.
 * Components having special characteristics are marked Δ and must be replaced with part having specifications equal to those originally installed.
 * Schematic diagram is subject to change without notice.

* 電圧は、10MΩV DC電圧計で測定したものです。
 * 特別な特性を有する部品は、Δ印記を付し、同等の特性を有する部品に交換してください。
 * 本図は、仕様変更等により、図面と異なる場合があります。

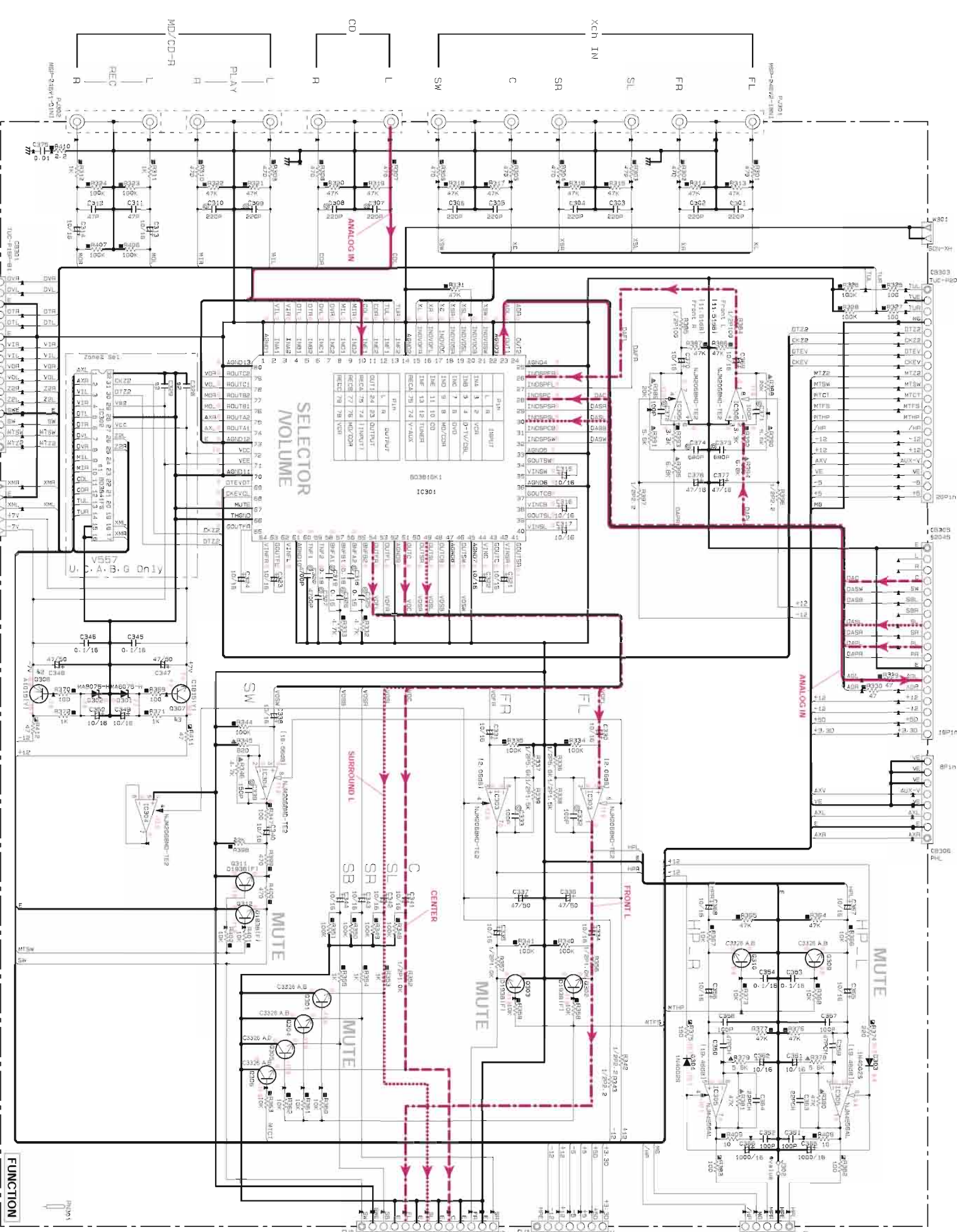

Part No.	Part Name	Remarks
K1	RESISTOR	
K2	RESISTOR	
K3	RESISTOR	

Part No.	Part Name	Remarks
K4	RESISTOR	
K5	RESISTOR	

Part No.	Part Name	Remarks
K6	RESISTOR	
K7	RESISTOR	

Part No.	Part Name	Remarks
K8	RESISTOR	
K9	RESISTOR	

IC301: 803918K1 7-channel Volume IC for 7-channel

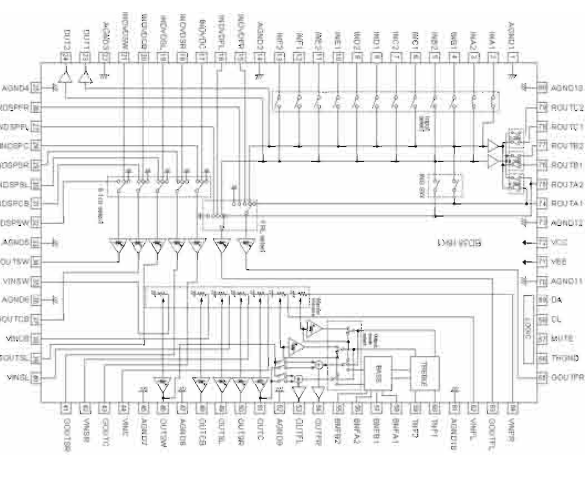

NOTICE (continued)

(J)..... JAPAN
 (U)..... U.S.A.
 (C)..... CANADA
 (R)..... GENERAL
 (T)..... CHINA
 (K)..... KOREA
 (A)..... AUSTRALIA
 (B)..... BRITISH
 (G)..... EUROPE
 (L)..... SINGAPORE
 (E)..... SOUTH EUROPE
 (V)..... TAIWAN

* All voltages are measured with a 10MΩ/V DC electronic volt meter.
 * The value of the resistor is indicated by the number in the circle.
 * The value of the capacitor is indicated by the number in the circle.
 * The value of the inductor is indicated by the number in the circle.
 * The value of the diode is indicated by the number in the circle.
 * The value of the transistor is indicated by the number in the circle.
 * The value of the tube is indicated by the number in the circle.
 * The value of the relay is indicated by the number in the circle.
 * The value of the switch is indicated by the number in the circle.
 * The value of the connector is indicated by the number in the circle.
 * The value of the terminal is indicated by the number in the circle.
 * The value of the wire is indicated by the number in the circle.
 * The value of the ground is indicated by the number in the circle.

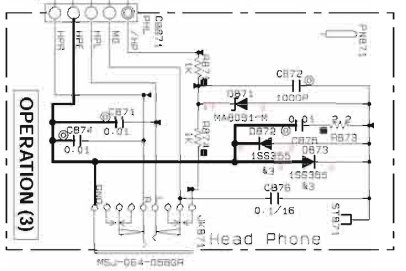
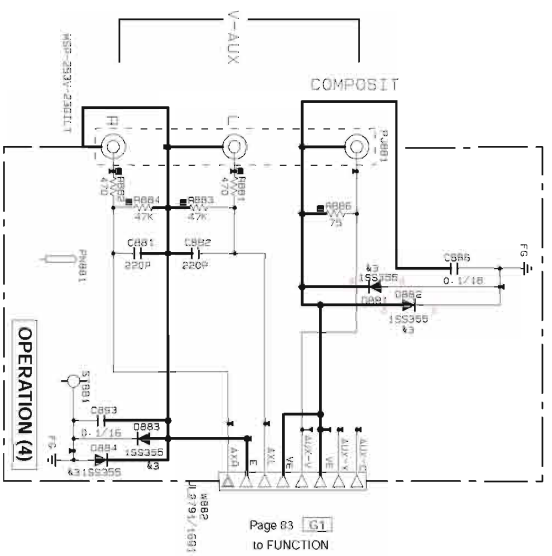
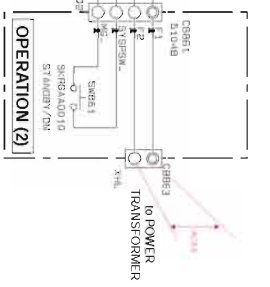
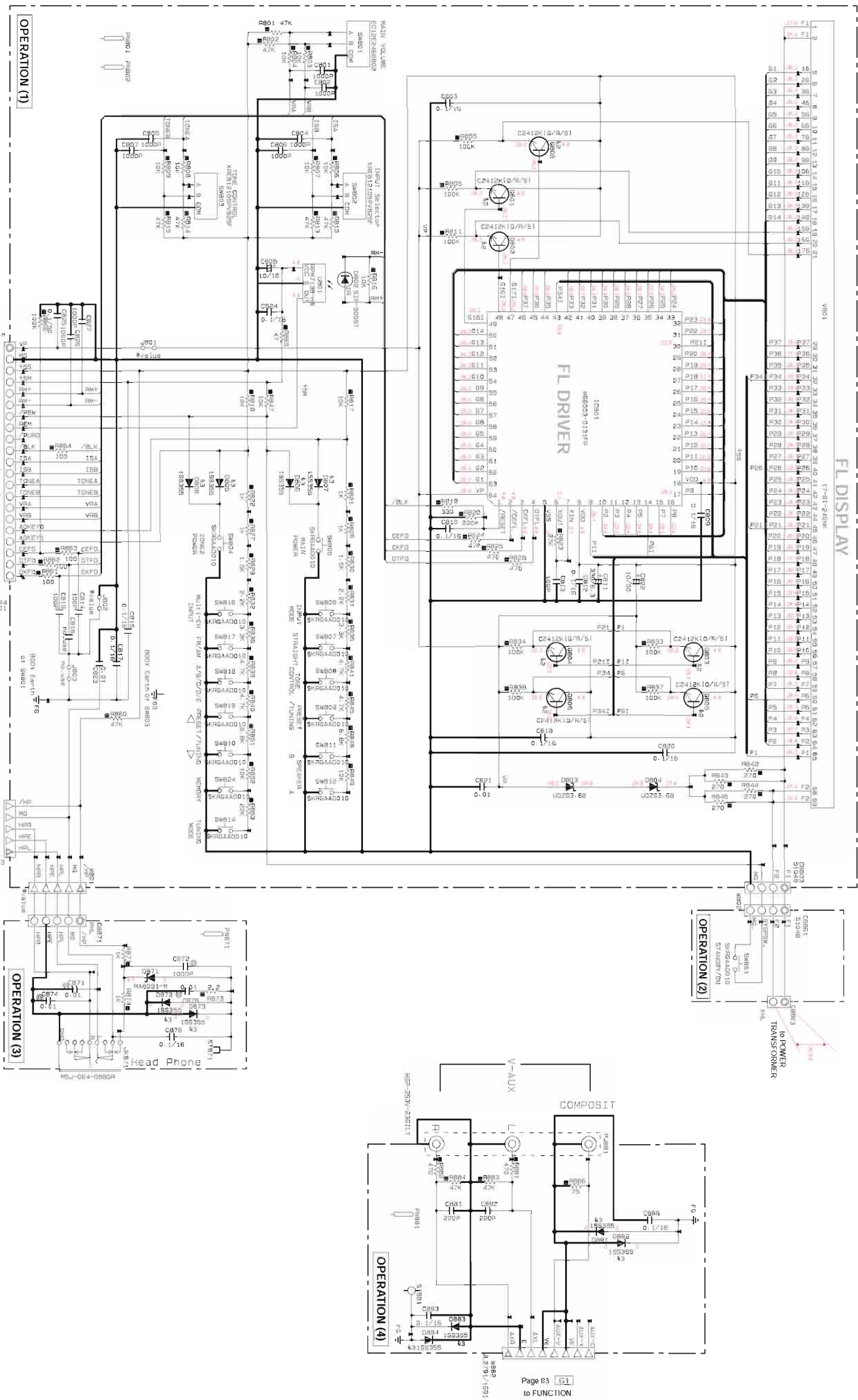

Page 86 [19] to SUBTR (2)
 Page 83 [23] to FUNCTION

REMARKS	PARTS NAME
NO MARK	ELECTROLYTIC CAPACITOR
NO MARK	TANTALUM CAPACITOR
NO MARK	CERAMIC CAPACITOR
NO MARK	CERAMIC TUBULAR CAPACITOR
NO MARK	POLYESTER FILM CAPACITOR
NO MARK	POLYSTYRENE FILM CAPACITOR
NO MARK	MICA CAPACITOR
NO MARK	POLYPROPYLENE FILM CAPACITOR
NO MARK	SEMICONDUCTIVE CERAMIC CAPACITOR
NO MARK	POLYMER/ELECTROLYTE FILM CAPACITOR

REMARKS	PARTS NAME
NO MARK	CARBON FILM RESISTOR (R=1)
NO MARK	CARBON FILM RESISTOR (R=10)
NO MARK	METAL OXIDE FILM RESISTOR
NO MARK	METAL PLATE RESISTOR
NO MARK	THE PROOF CARBON FILM RESISTOR
NO MARK	CEMENT NO. 010 RESISTOR
NO MARK	SEMI VARIABLE RESISTOR
NO MARK	CHIP RESISTOR

NOTICE (mode 1)
 (J)..... JAPAN
 (U)..... U.S.A
 (C)..... CANADA
 (I)..... GENERAL
 (T)..... CHINA
 (K)..... KOREA
 (A)..... AUSTRALIA
 (B)..... BRITISH
 (G)..... EUROPE
 (L)..... SINGAPORE
 (E)..... SOUTH EUROPE
 (V)..... TAIWAN

Interchangeable Parts at Manufacture-Stage

Part. Reference Parts Number	Parts Name
K1	
K2	
K3	
K4	
K5	
K6	

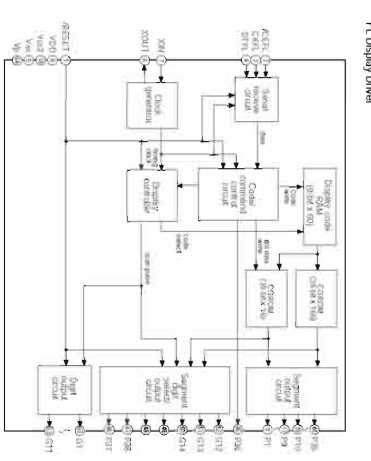

* All voltages are measured with a 100KΩ DC electronic voltmeter.
 * Components having special characteristics are marked A, and must be replaced with parts having specifications equal to those originally installed.
 * Schematic diagram is subject to change without notice.

* 電圧は、100KΩ DC電圧計で測定したものです。
 * 特別な特性を有する部品は、Aと表示し、同等の性能の部品で置き換える必要があります。
 * 本図は、仕様変更のため、無断で変更される場合があります。

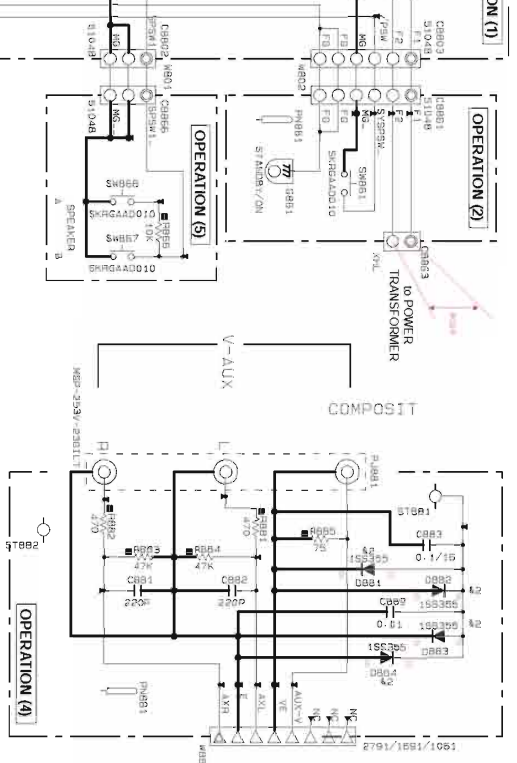
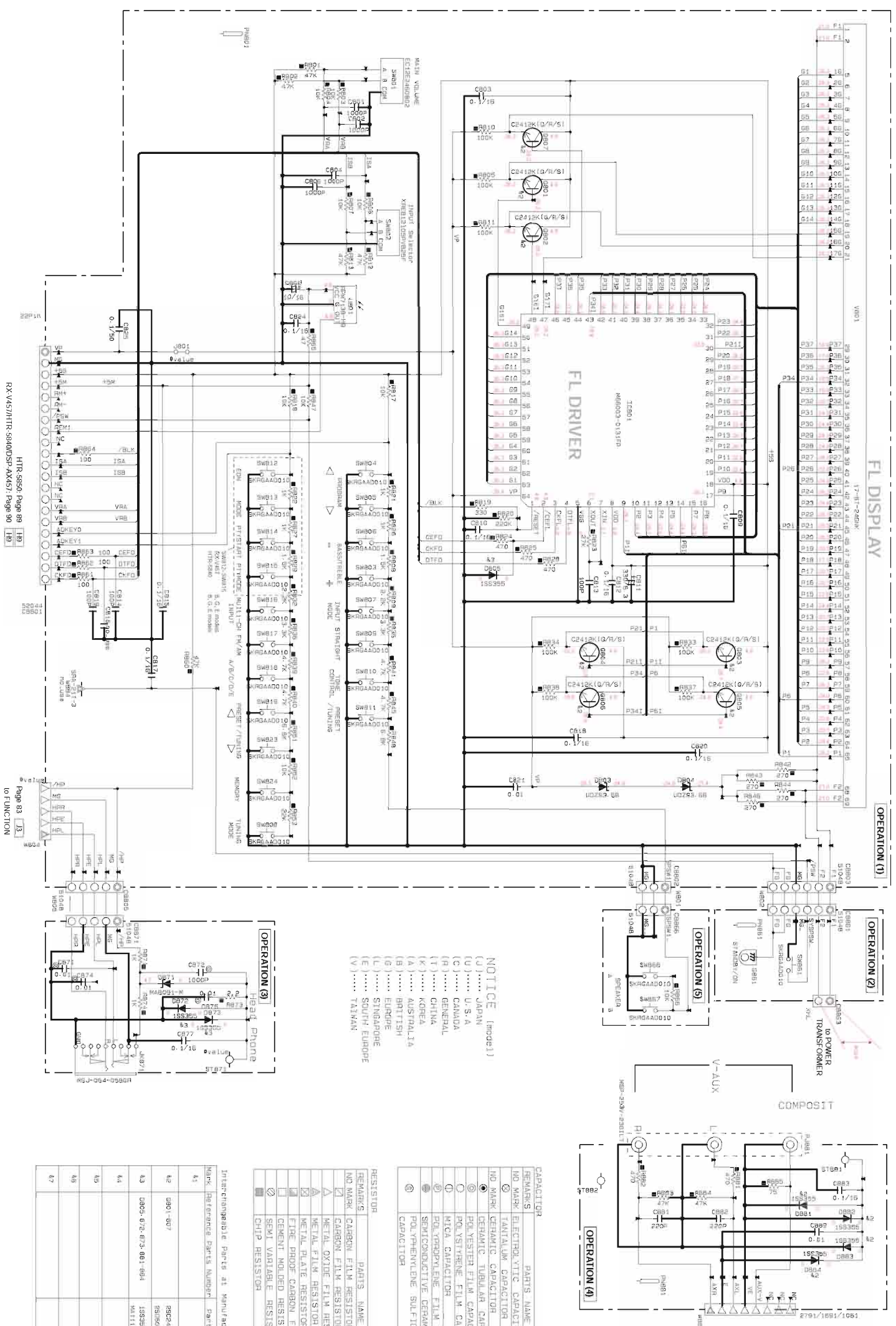

NOTICE (Imp'd.)

(J)..... JAPAN
 (U)..... U.S.A
 (C)..... CANADA
 (R)..... GENERAL
 (T)..... CHINA
 (K)..... KOREA
 (A)..... AUSTRALIA
 (B)..... BRITISH
 (G)..... EUROPE
 (L)..... SINGAPORE
 (E)..... SOUTH EUROPE
 (V)..... TAINAN

REMARKS	PARTS NAME
NO MARK	ELECTROLYTIC CAPACITOR
NO MARK	TANTALUM CAPACITOR
NO MARK	CERAMIC CAPACITOR
NO MARK	CERAMIC TUBULAR CAPACITOR
NO MARK	POLYESTER FILM CAPACITOR
NO MARK	POLYSTYRENE FILM CAPACITOR
NO MARK	MICA CAPACITOR
NO MARK	POLYPROPYLENE FILM CAPACITOR
NO MARK	SEMICONDUCTIVE CERAMIC CAPACITOR
NO MARK	POLYMERIZED SULFIDE FILM CAPACITOR

REMARKS	PARTS NAME
NO MARK	CARBON FILM RESISTOR (P=5)
NO MARK	CARBON FILM RESISTOR (P=10)
NO MARK	METAL OXIDE FILM RESISTOR
NO MARK	METAL FILM RESISTOR
NO MARK	METAL PLATE RESISTOR
NO MARK	FINE PROOF CARBON FILM RESISTOR
NO MARK	CEMENT MOLDED RESISTOR
NO MARK	SEM1 VARIABLE RESISTOR
NO MARK	CHIP RESISTOR

Mark	Reference Parts Number	Part's Name
K1		
K2	0901-907	2SC2412R(G/R/S)
K3	0905-972-981-984	5S2395
K4		MA111
K5		
K6		
K7		

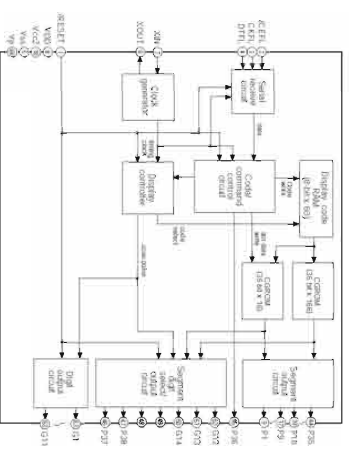

IC201, M6903, 0101FP
 FL Display Drive

* All voltages are measured with a 10MΩV DC electronic voltmeter.
 * Components having special characteristics are marked with a special symbol.
 * Schematic diagram is subject to change without notice.

* 電圧は、10MΩV DC電圧計で測定した値です。
 * 特殊な特性を有する部品は、特殊記号を付して示します。
 * 本図は、仕様変更を伴う場合があります。変更なしと表示されています。

1
2
3
4
5
6
7
8
9
10

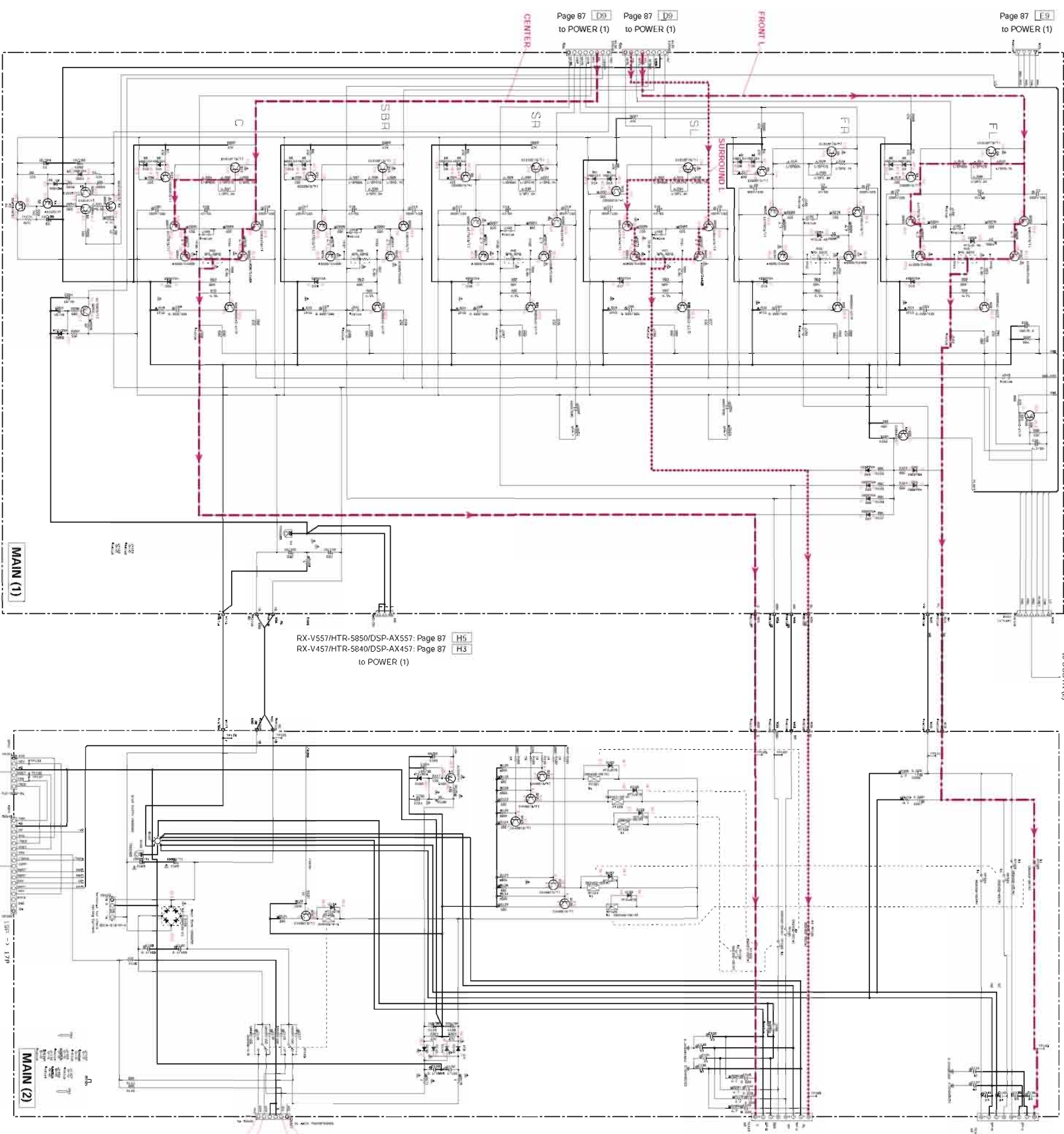

RX-V557/HTR-5850/DSP-AXX57: Page 87 [H5]
 RX-V457/HTR-5840/DSP-AXX57: Page 87 [H3]
 to POWER (1)

RX-V557/DSP-AXX57: Page 88 [G6]
 HTR-5850: Page 89 [G6]
 RX-V457/HTR-5840/DSP-AXX57: Page 90 [G6]
 to SUBTR (2)

NO.	DESCRIPTION	QTY	REMARKS
1
2
3
4
5
6
7
8
9
10

NO.	DESCRIPTION	QTY	REMARKS
1
2
3
4
5
6
7
8
9
10

NO.	DESCRIPTION	QTY	REMARKS
1
2
3
4
5
6
7
8
9
10

* All voltages are measured with a 10kΩV DC electric voltmeter.
 * Components having special characteristics are marked A, and must be replaced with parts having specifications equal to those originally installed.
 * Schematic diagram is subject to change without notice.

電圧は、内蔵抵抗10kΩの電圧計で測定したものです。
 * Aは、特別な特性を有する部品を示しています。取替の際は必ず同等の部品を交換してください。
 * 本図は、仕様変更の可能性があります。取替の際は必ず同等の部品を交換してください。

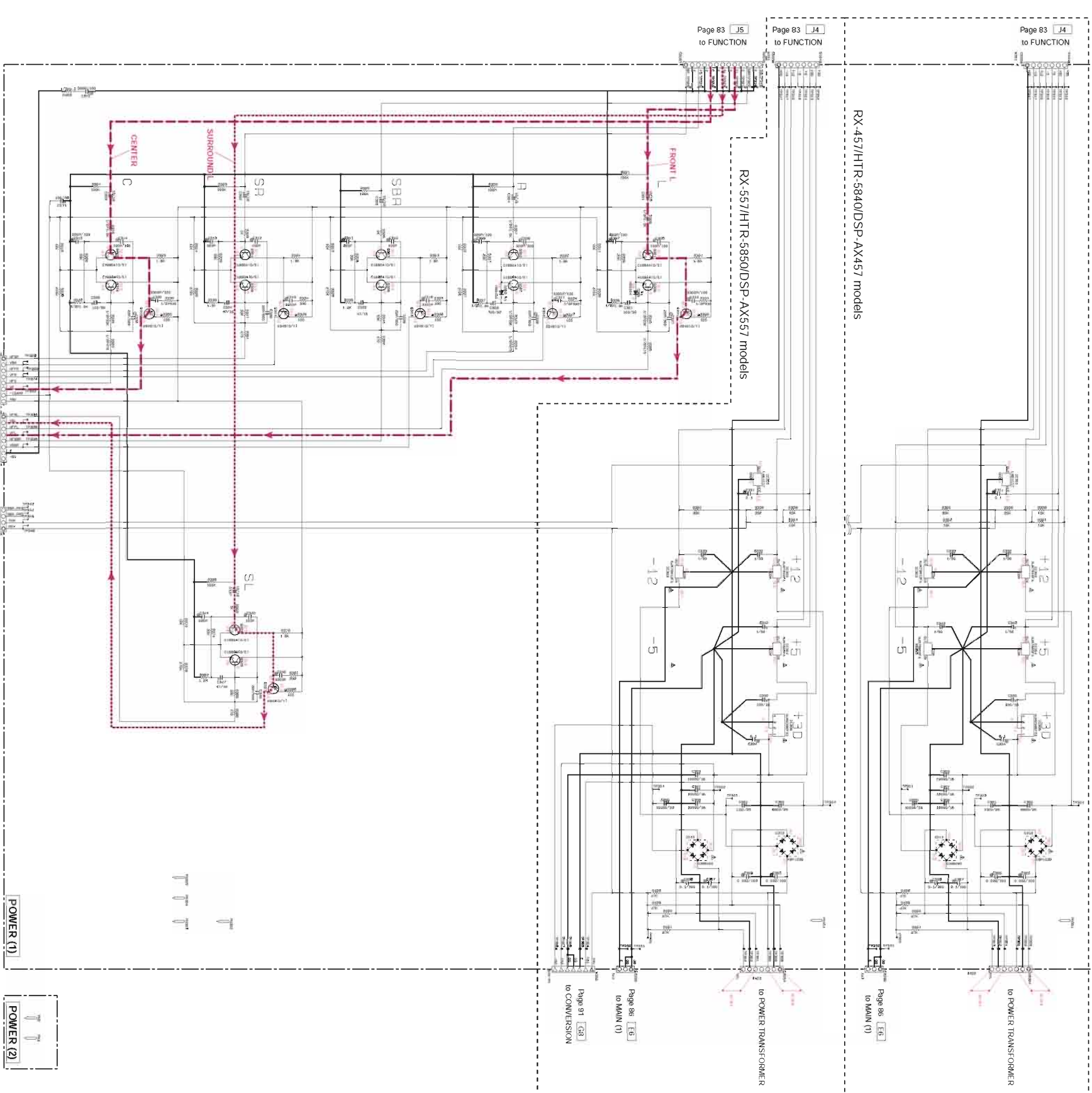

NO.	NAME	VALUE	UNIT
1	RESISTOR	10K	Ω
2	RESISTOR	100K	Ω
3	RESISTOR	1K	Ω
4	RESISTOR	10K	Ω
5	RESISTOR	100K	Ω
6	RESISTOR	1K	Ω
7	RESISTOR	10K	Ω
8	RESISTOR	100K	Ω
9	RESISTOR	1K	Ω
10	RESISTOR	10K	Ω
11	RESISTOR	100K	Ω
12	RESISTOR	1K	Ω
13	RESISTOR	10K	Ω
14	RESISTOR	100K	Ω
15	RESISTOR	1K	Ω
16	RESISTOR	10K	Ω
17	RESISTOR	100K	Ω
18	RESISTOR	1K	Ω
19	RESISTOR	10K	Ω
20	RESISTOR	100K	Ω
21	RESISTOR	1K	Ω
22	RESISTOR	10K	Ω
23	RESISTOR	100K	Ω
24	RESISTOR	1K	Ω
25	RESISTOR	10K	Ω
26	RESISTOR	100K	Ω
27	RESISTOR	1K	Ω
28	RESISTOR	10K	Ω
29	RESISTOR	100K	Ω
30	RESISTOR	1K	Ω
31	RESISTOR	10K	Ω
32	RESISTOR	100K	Ω
33	RESISTOR	1K	Ω
34	RESISTOR	10K	Ω
35	RESISTOR	100K	Ω
36	RESISTOR	1K	Ω
37	RESISTOR	10K	Ω
38	RESISTOR	100K	Ω
39	RESISTOR	1K	Ω
40	RESISTOR	10K	Ω
41	RESISTOR	100K	Ω
42	RESISTOR	1K	Ω
43	RESISTOR	10K	Ω
44	RESISTOR	100K	Ω
45	RESISTOR	1K	Ω
46	RESISTOR	10K	Ω
47	RESISTOR	100K	Ω
48	RESISTOR	1K	Ω
49	RESISTOR	10K	Ω
50	RESISTOR	100K	Ω
51	RESISTOR	1K	Ω
52	RESISTOR	10K	Ω
53	RESISTOR	100K	Ω
54	RESISTOR	1K	Ω
55	RESISTOR	10K	Ω
56	RESISTOR	100K	Ω
57	RESISTOR	1K	Ω
58	RESISTOR	10K	Ω
59	RESISTOR	100K	Ω
60	RESISTOR	1K	Ω
61	RESISTOR	10K	Ω
62	RESISTOR	100K	Ω
63	RESISTOR	1K	Ω
64	RESISTOR	10K	Ω
65	RESISTOR	100K	Ω
66	RESISTOR	1K	Ω
67	RESISTOR	10K	Ω
68	RESISTOR	100K	Ω
69	RESISTOR	1K	Ω
70	RESISTOR	10K	Ω
71	RESISTOR	100K	Ω
72	RESISTOR	1K	Ω
73	RESISTOR	10K	Ω
74	RESISTOR	100K	Ω
75	RESISTOR	1K	Ω
76	RESISTOR	10K	Ω
77	RESISTOR	100K	Ω
78	RESISTOR	1K	Ω
79	RESISTOR	10K	Ω
80	RESISTOR	100K	Ω
81	RESISTOR	1K	Ω
82	RESISTOR	10K	Ω
83	RESISTOR	100K	Ω
84	RESISTOR	1K	Ω
85	RESISTOR	10K	Ω
86	RESISTOR	100K	Ω
87	RESISTOR	1K	Ω
88	RESISTOR	10K	Ω
89	RESISTOR	100K	Ω
90	RESISTOR	1K	Ω
91	RESISTOR	10K	Ω
92	RESISTOR	100K	Ω
93	RESISTOR	1K	Ω
94	RESISTOR	10K	Ω
95	RESISTOR	100K	Ω
96	RESISTOR	1K	Ω
97	RESISTOR	10K	Ω
98	RESISTOR	100K	Ω
99	RESISTOR	1K	Ω
100	RESISTOR	10K	Ω

NO.	NAME	VALUE	UNIT
1	CAPACITOR	1000	μF
2	CAPACITOR	100	μF
3	CAPACITOR	10	μF
4	CAPACITOR	1	μF
5	CAPACITOR	0.1	μF
6	CAPACITOR	0.01	μF
7	CAPACITOR	0.001	μF
8	CAPACITOR	1000	μF
9	CAPACITOR	100	μF
10	CAPACITOR	10	μF
11	CAPACITOR	1	μF
12	CAPACITOR	0.1	μF
13	CAPACITOR	0.01	μF
14	CAPACITOR	0.001	μF
15	CAPACITOR	1000	μF
16	CAPACITOR	100	μF
17	CAPACITOR	10	μF
18	CAPACITOR	1	μF
19	CAPACITOR	0.1	μF
20	CAPACITOR	0.01	μF
21	CAPACITOR	0.001	μF
22	CAPACITOR	1000	μF
23	CAPACITOR	100	μF
24	CAPACITOR	10	μF
25	CAPACITOR	1	μF
26	CAPACITOR	0.1	μF
27	CAPACITOR	0.01	μF
28	CAPACITOR	0.001	μF
29	CAPACITOR	1000	μF
30	CAPACITOR	100	μF
31	CAPACITOR	10	μF
32	CAPACITOR	1	μF
33	CAPACITOR	0.1	μF
34	CAPACITOR	0.01	μF
35	CAPACITOR	0.001	μF
36	CAPACITOR	1000	μF
37	CAPACITOR	100	μF
38	CAPACITOR	10	μF
39	CAPACITOR	1	μF
40	CAPACITOR	0.1	μF
41	CAPACITOR	0.01	μF
42	CAPACITOR	0.001	μF
43	CAPACITOR	1000	μF
44	CAPACITOR	100	μF
45	CAPACITOR	10	μF
46	CAPACITOR	1	μF
47	CAPACITOR	0.1	μF
48	CAPACITOR	0.01	μF
49	CAPACITOR	0.001	μF
50	CAPACITOR	1000	μF
51	CAPACITOR	100	μF
52	CAPACITOR	10	μF
53	CAPACITOR	1	μF
54	CAPACITOR	0.1	μF
55	CAPACITOR	0.01	μF
56	CAPACITOR	0.001	μF
57	CAPACITOR	1000	μF
58	CAPACITOR	100	μF
59	CAPACITOR	10	μF
60	CAPACITOR	1	μF
61	CAPACITOR	0.1	μF
62	CAPACITOR	0.01	μF
63	CAPACITOR	0.001	μF
64	CAPACITOR	1000	μF
65	CAPACITOR	100	μF
66	CAPACITOR	10	μF
67	CAPACITOR	1	μF
68	CAPACITOR	0.1	μF
69	CAPACITOR	0.01	μF
70	CAPACITOR	0.001	μF
71	CAPACITOR	1000	μF
72	CAPACITOR	100	μF
73	CAPACITOR	10	μF
74	CAPACITOR	1	μF
75	CAPACITOR	0.1	μF
76	CAPACITOR	0.01	μF
77	CAPACITOR	0.001	μF
78	CAPACITOR	1000	μF
79	CAPACITOR	100	μF
80	CAPACITOR	10	μF
81	CAPACITOR	1	μF
82	CAPACITOR	0.1	μF
83	CAPACITOR	0.01	μF
84	CAPACITOR	0.001	μF
85	CAPACITOR	1000	μF
86	CAPACITOR	100	μF
87	CAPACITOR	10	μF
88	CAPACITOR	1	μF
89	CAPACITOR	0.1	μF
90	CAPACITOR	0.01	μF
91	CAPACITOR	0.001	μF
92	CAPACITOR	1000	μF
93	CAPACITOR	100	μF
94	CAPACITOR	10	μF
95	CAPACITOR	1	μF
96	CAPACITOR	0.1	μF
97	CAPACITOR	0.01	μF
98	CAPACITOR	0.001	μF
99	CAPACITOR	1000	μF
100	CAPACITOR	100	μF

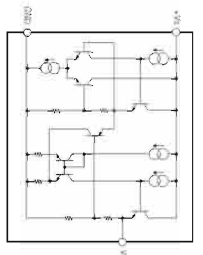

IC301 LM50CZ
Temperature Sensor

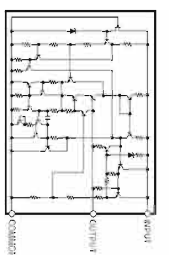

IC302 NLM7912FA
Voltage Regulator

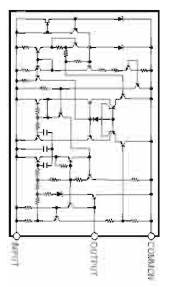

IC303 NLM79M12FA
Voltage Regulator

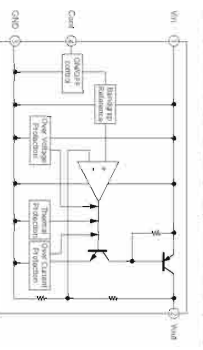

IC304 NLM288F
LOW DROPOUT VOLTAGE REGULATOR WITH ON/OFF CONTROL

* All notations are measured with a 10kΩV_{DC} electronic voltmeter.
 * All parts having specifications equal to those originally installed.
 * Schematic diagram is subject to change without notice.

電圧計は、10kΩV_{DC}の電圧計で測定した値を示す。
 * 元の仕様と同等の部品、同等の規格と同等の品質のものを使用する。
 * 本図面の仕様は変更される場合があります。変更なしと表示するものではありません。

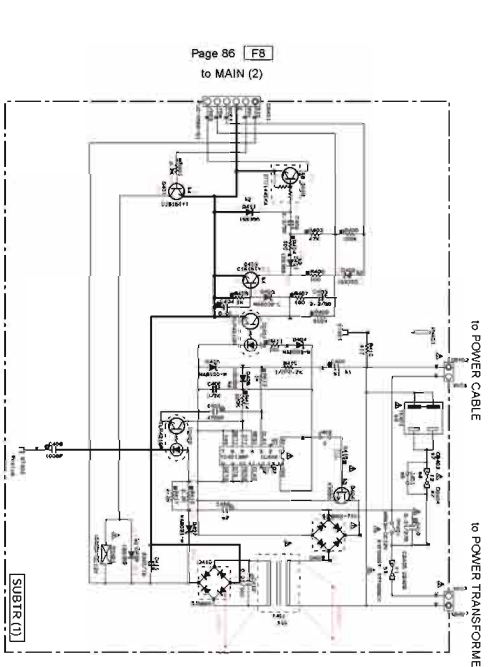
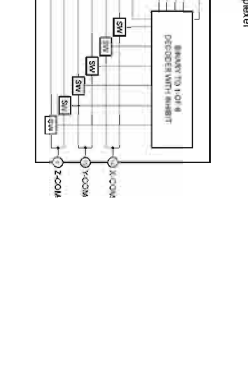
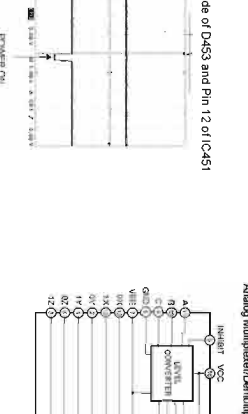
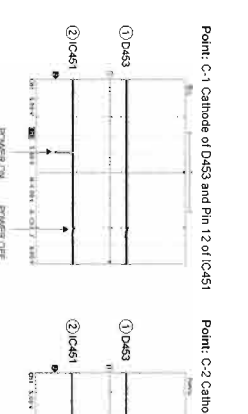
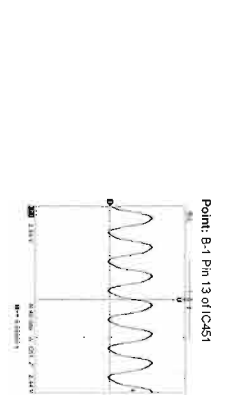
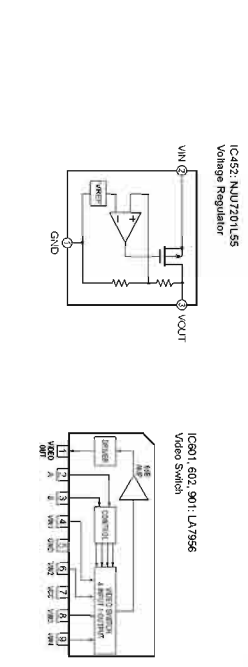
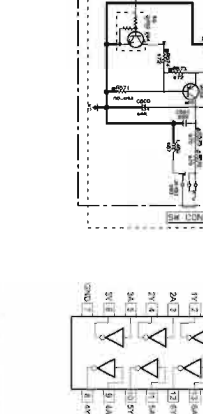
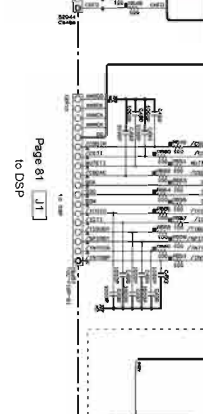
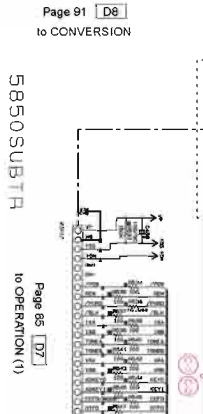
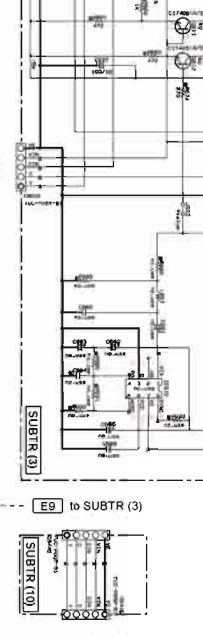
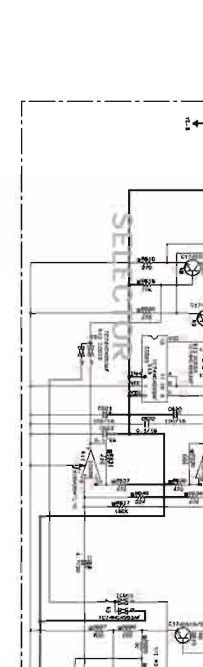
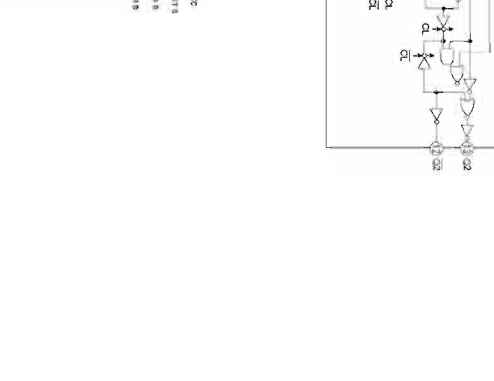
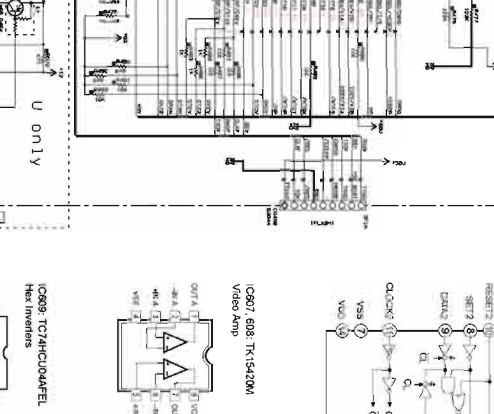
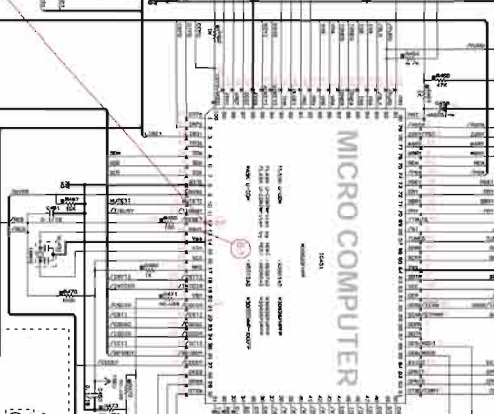
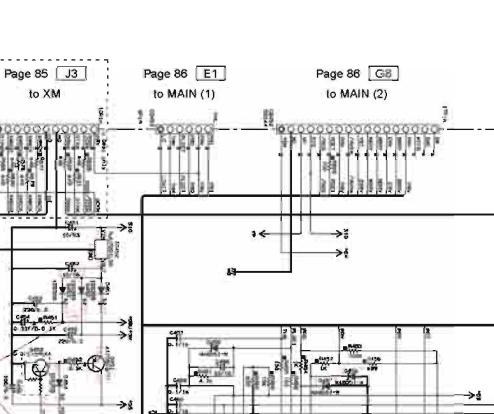
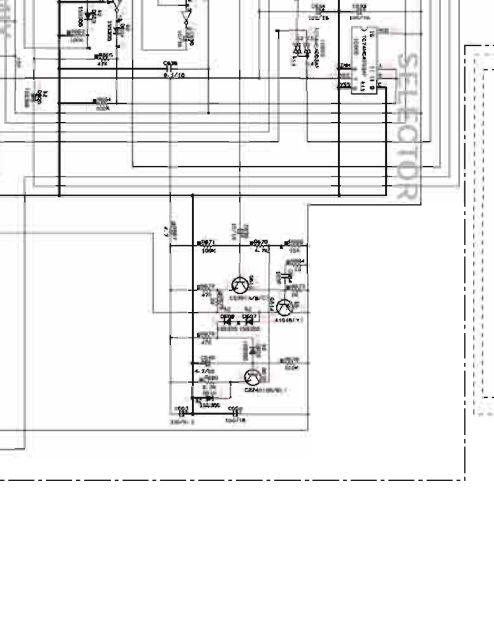
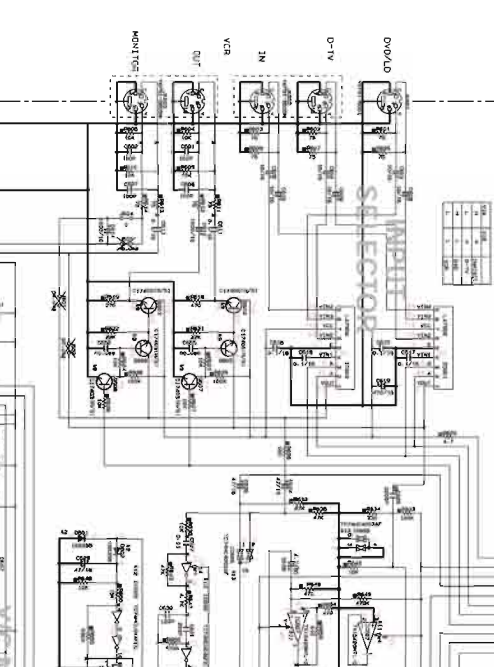
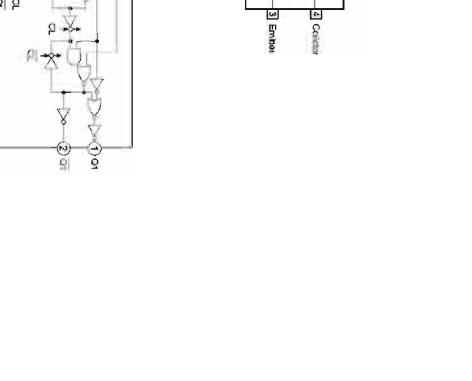
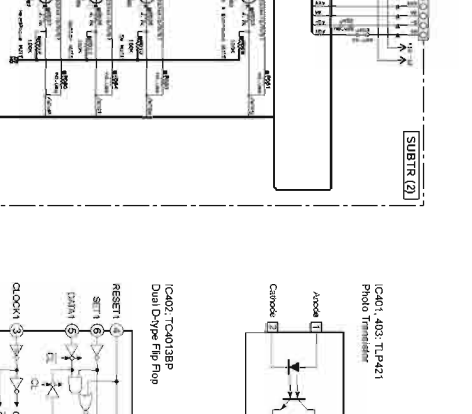
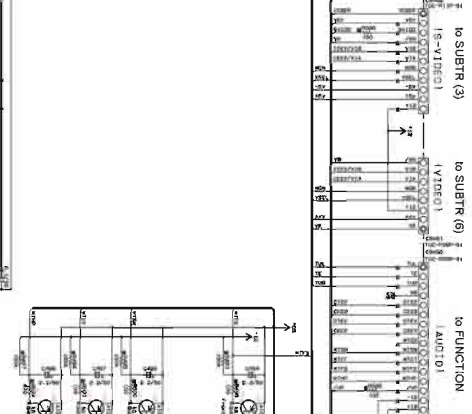
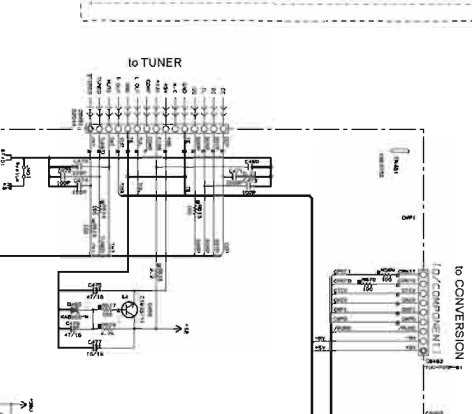
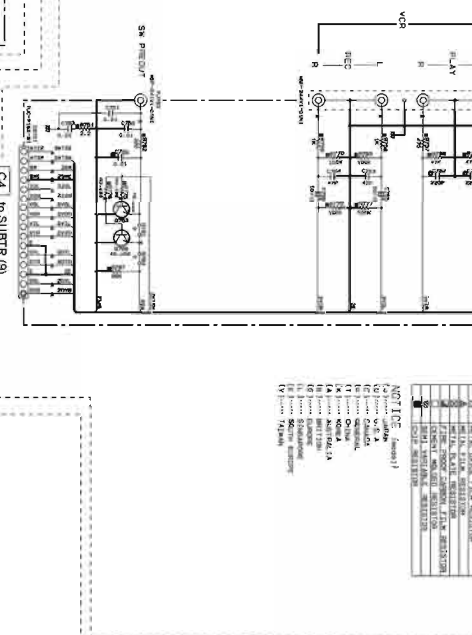
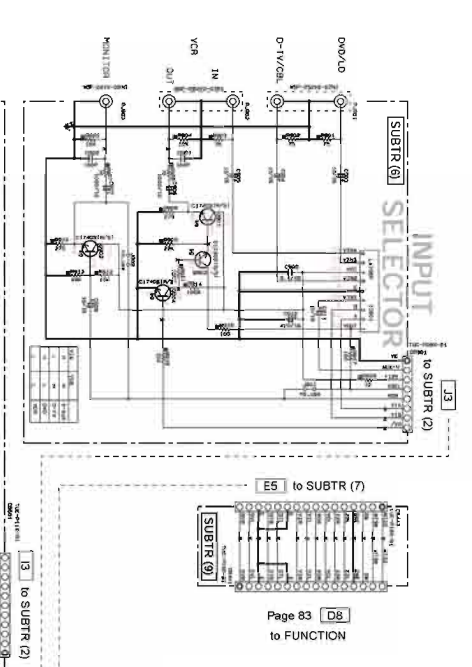
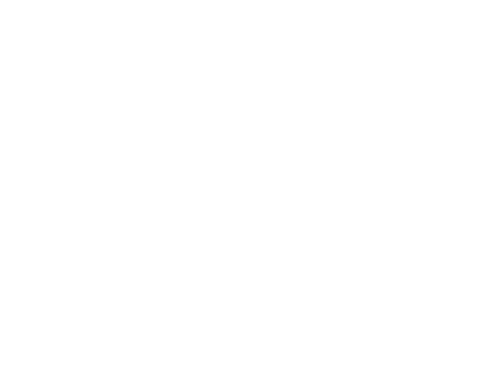

Table with 2 columns: Component No. and Description. Lists various components like resistors, capacitors, and diodes used in the power section.

Table with 2 columns: Component No. and Description. Lists various components like resistors, capacitors, and diodes used in the power section.

Table with 2 columns: Component No. and Description. Lists various components like resistors, capacitors, and diodes used in the power section.

Table with 2 columns: Component No. and Description. Lists various components like resistors, capacitors, and diodes used in the power section.



All voltages are measured with a 10kΩ/V DC electronic volt meter.
Components having special characteristics are marked with an asterisk.
Schematic diagram is subject to change without notice.

※ 電圧は、10kΩ/V DC電圧計を用いて測定したものです。
※ 特殊な特性を有する部品は、*印で示されています。
※ 回路図は、変更される場合があります。

NOTICE (事項)

1	この図面は、製品の仕様を説明するために作成されたものであり、製品の改良や変更により、図面の内容が変更される場合があります。
2	この図面は、製品の仕様を説明するために作成されたものであり、製品の改良や変更により、図面の内容が変更される場合があります。
3	この図面は、製品の仕様を説明するために作成されたものであり、製品の改良や変更により、図面の内容が変更される場合があります。
4	この図面は、製品の仕様を説明するために作成されたものであり、製品の改良や変更により、図面の内容が変更される場合があります。
5	この図面は、製品の仕様を説明するために作成されたものであり、製品の改良や変更により、図面の内容が変更される場合があります。
6	この図面は、製品の仕様を説明するために作成されたものであり、製品の改良や変更により、図面の内容が変更される場合があります。
7	この図面は、製品の仕様を説明するために作成されたものであり、製品の改良や変更により、図面の内容が変更される場合があります。
8	この図面は、製品の仕様を説明するために作成されたものであり、製品の改良や変更により、図面の内容が変更される場合があります。
9	この図面は、製品の仕様を説明するために作成されたものであり、製品の改良や変更により、図面の内容が変更される場合があります。
10	この図面は、製品の仕様を説明するために作成されたものであり、製品の改良や変更により、図面の内容が変更される場合があります。

COMPONENTS LIST (部品表)

NO.	QTY	DESCRIPTION	REMARKS
1	1	IC451: NJM7211LS	Voltage Regulator
2	1	IC452: LC72323PM	ROS Signal Processor
3	1	IC453: LA9596	Video Synchronizer
4	1	IC454: TC9401BSP	Equalizer
5	1	IC455: NJM7231M	Video Amp
6	1	IC456: TC9401BSP	Equalizer
7	1	IC457: NJM7231M	Video Amp
8	1	IC458: TC9401BSP	Equalizer
9	1	IC459: NJM7231M	Video Amp
10	1	IC460: TC9401BSP	Equalizer

COMPONENTS LIST (部品表) (Continued)

NO.	QTY	DESCRIPTION	REMARKS
11	1	IC461: TC9401BSP	Equalizer
12	1	IC462: NJM7231M	Video Amp
13	1	IC463: TC9401BSP	Equalizer
14	1	IC464: NJM7231M	Video Amp
15	1	IC465: TC9401BSP	Equalizer
16	1	IC466: NJM7231M	Video Amp
17	1	IC467: TC9401BSP	Equalizer
18	1	IC468: NJM7231M	Video Amp
19	1	IC469: TC9401BSP	Equalizer
20	1	IC470: NJM7231M	Video Amp

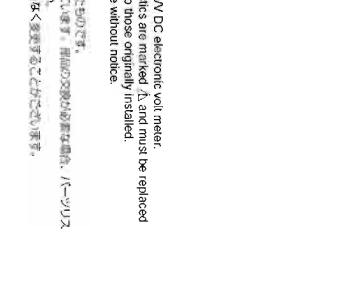
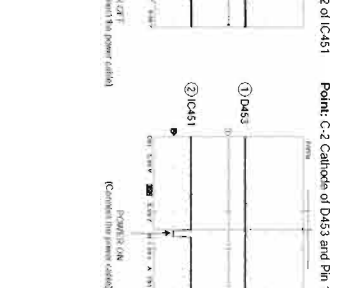
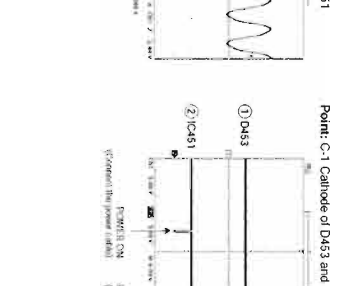
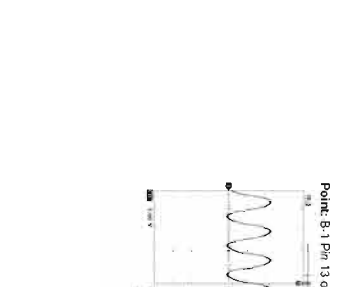
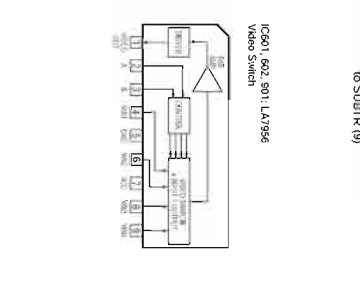
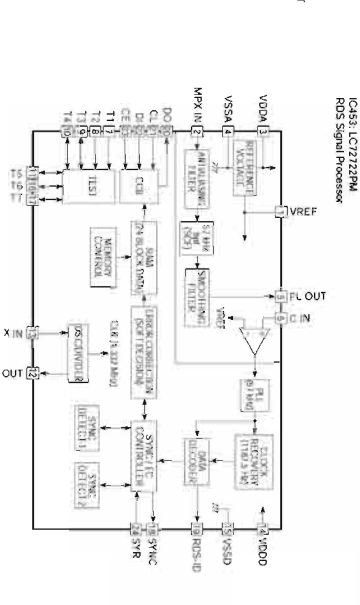
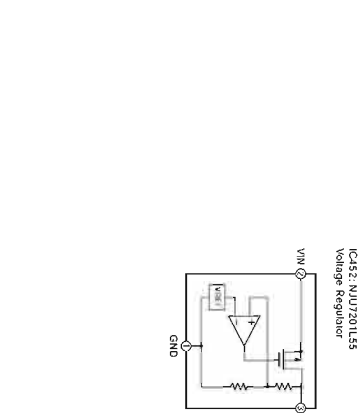
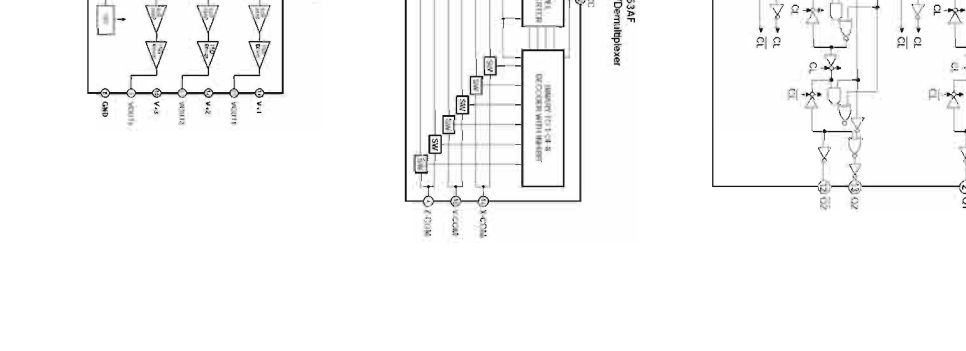
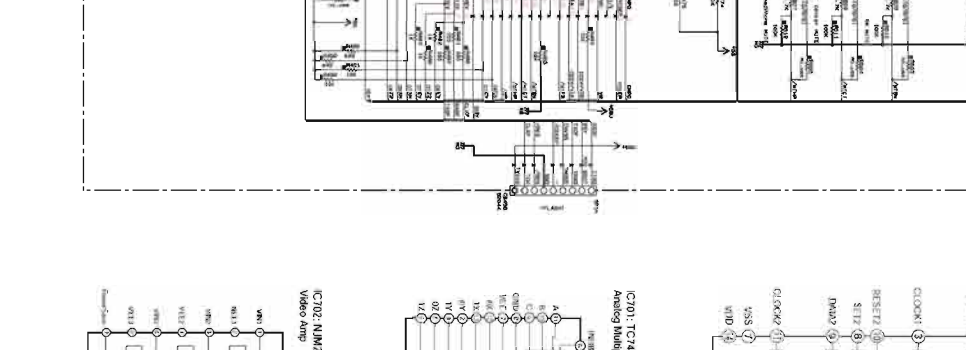
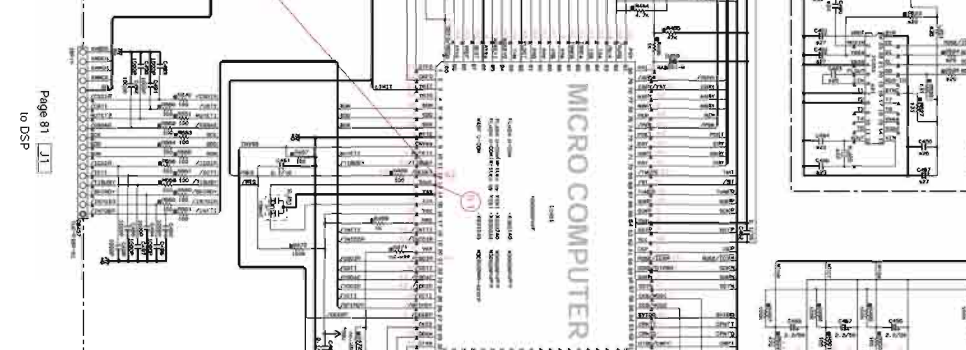
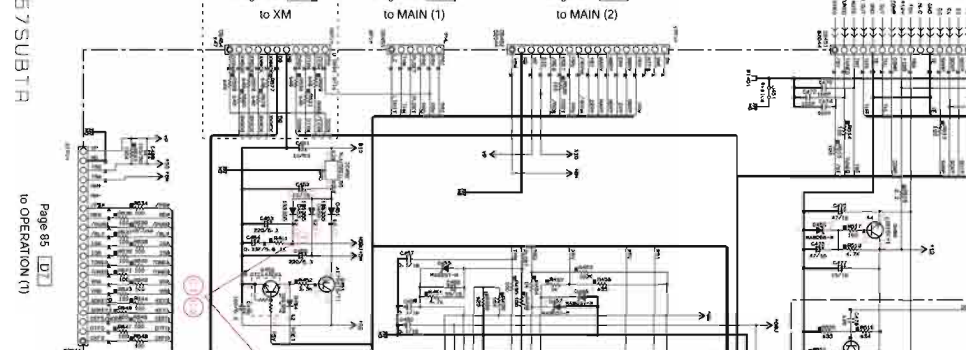
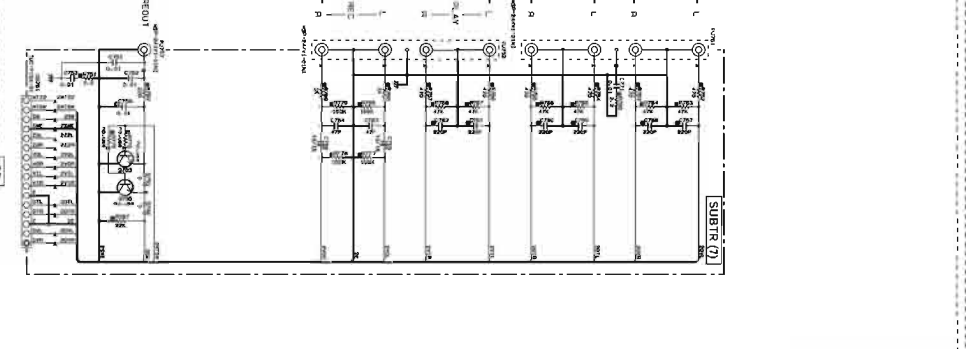
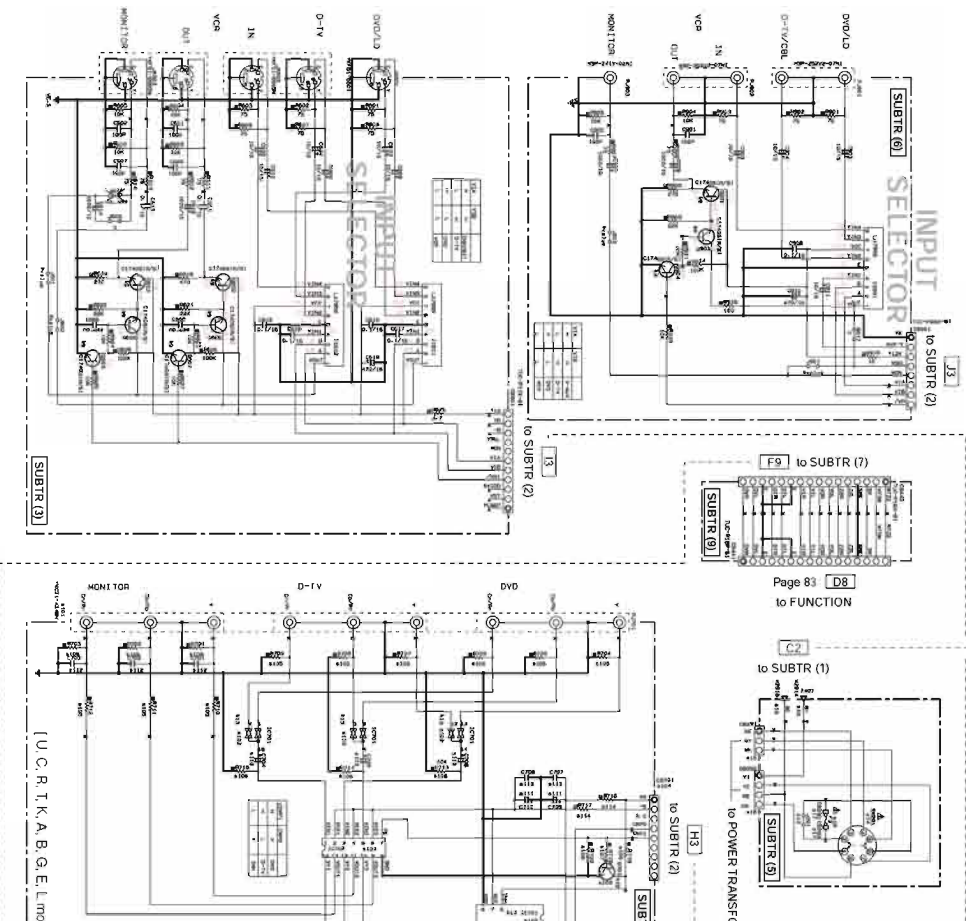
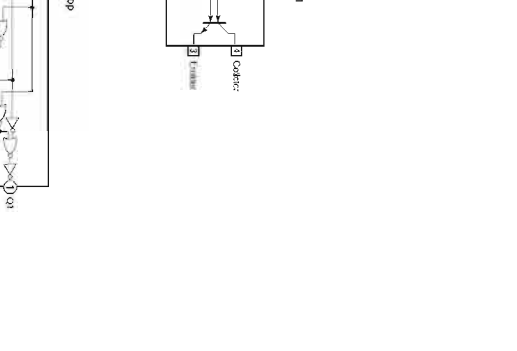
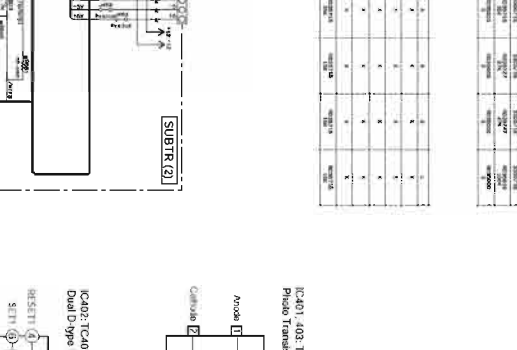
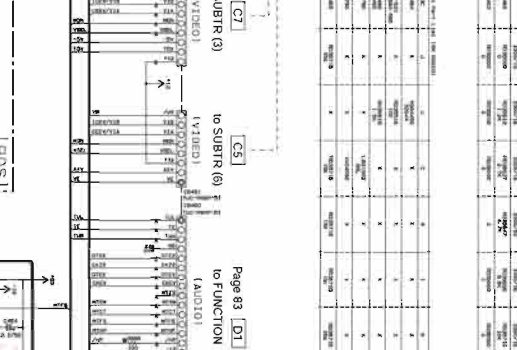
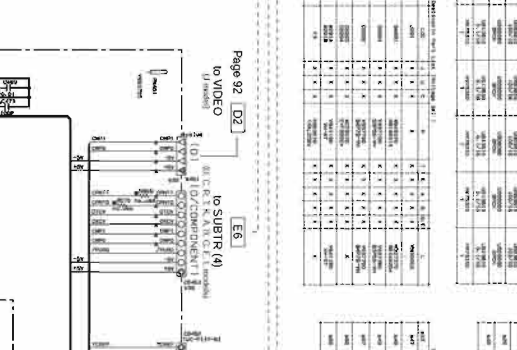
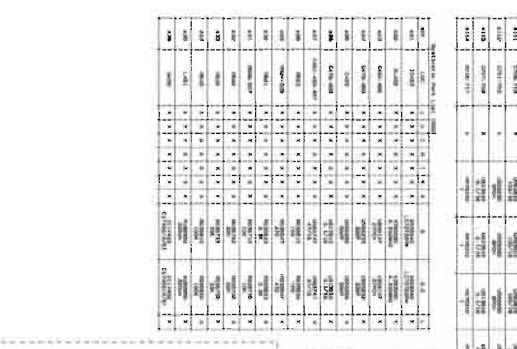
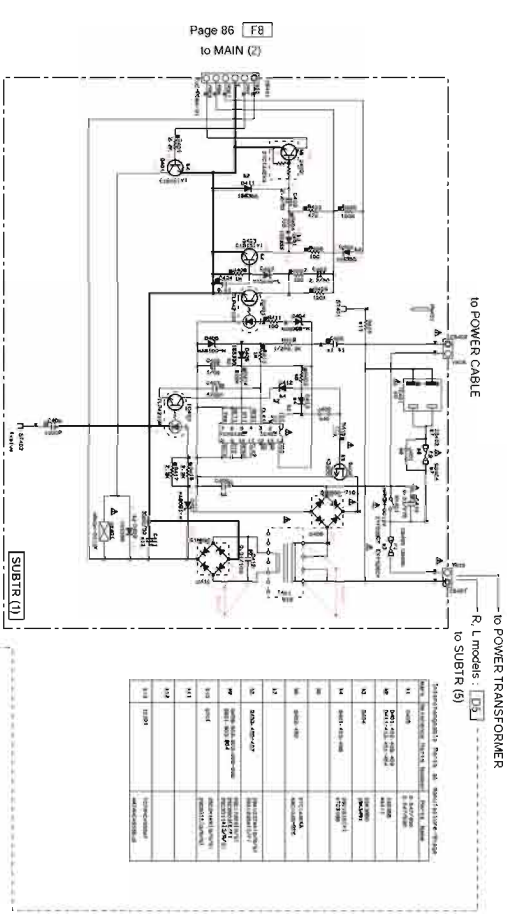

Point: B-1 Pin 13 of IC451
 Point: C-1 Cathode of D453 and Pin 12 of IC451
 Point: C-2 Cathode of D453 and Pin 12 of IC451

IC451: NJM7211LS
Voltage Regulator

IC452: LC72323PM
ROS Signal Processor

IC453: LA9596
Video Synchronizer

IC454: TC9401BSP
Equalizer

IC455: NJM7231M
Video Amp

IC456: TC9401BSP
Equalizer

IC457: NJM7231M
Video Amp

IC458: TC9401BSP
Equalizer

IC459: NJM7231M
Video Amp

IC460: TC9401BSP
Equalizer

IC461: TC9401BSP
Equalizer

IC462: NJM7231M
Video Amp

IC463: TC9401BSP
Equalizer

IC464: NJM7231M
Video Amp

IC465: TC9401BSP
Equalizer

IC466: NJM7231M
Video Amp

IC467: TC9401BSP
Equalizer

IC468: NJM7231M
Video Amp

IC469: TC9401BSP
Equalizer

IC470: NJM7231M
Video Amp

IC451: NJM7211LS
Voltage Regulator

IC452: LC72323PM
ROS Signal Processor

IC453: LA9596
Video Synchronizer

IC454: TC9401BSP
Equalizer

IC455: NJM7231M
Video Amp

IC456: TC9401BSP
Equalizer

IC457: NJM7231M
Video Amp

IC458: TC9401BSP
Equalizer

IC459: NJM7231M
Video Amp

IC460: TC9401BSP
Equalizer

IC461: TC9401BSP
Equalizer

IC462: NJM7231M
Video Amp

IC463: TC9401BSP
Equalizer

IC464: NJM7231M
Video Amp

IC465: TC9401BSP
Equalizer

IC466: NJM7231M
Video Amp

IC467: TC9401BSP
Equalizer

IC468: NJM7231M
Video Amp

IC469: TC9401BSP
Equalizer

IC470: NJM7231M
Video Amp

All voltages are measured with a 10kΩV DC electronic volt meter.
 Components having special characteristics are marked (A) and must be replaced
 with parts having special characteristics equal to those originally installed.
 Schematic diagram is subject to change without notice.
 電圧は、10kΩVの直流電圧計で測定したものです。
 特別な特性を有する部品は(A)で示されています。特別な特性を有する部品に
 同等の部品を交換する必要があります。
 回路図は、予告なく変更される場合があります。

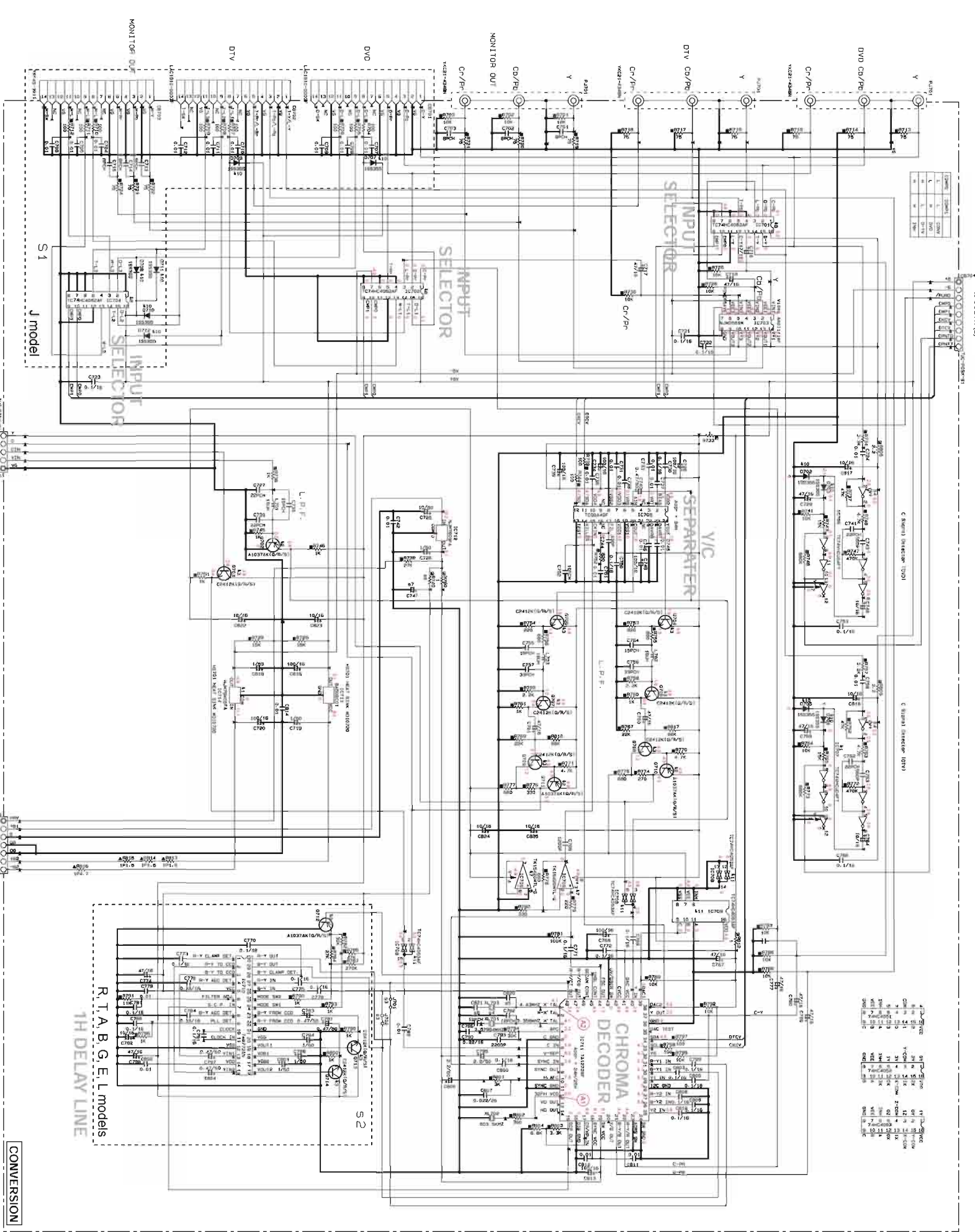

Point A-1 Pin 12 of IC711

Point A-2 Pin 1 of IC711

Pin	Symbol	Value	Notes
1	Y	0.1μF	Y
2	CB/Pb	0.1μF	CB/Pb
3	CR/Pr	0.1μF	CR/Pr
4	Y	0.1μF	Y
5	CB/Pb	0.1μF	CB/Pb
6	CR/Pr	0.1μF	CR/Pr
7	Y	0.1μF	Y
8	CB/Pb	0.1μF	CB/Pb
9	CR/Pr	0.1μF	CR/Pr
10	Y	0.1μF	Y
11	CB/Pb	0.1μF	CB/Pb
12	CR/Pr	0.1μF	CR/Pr

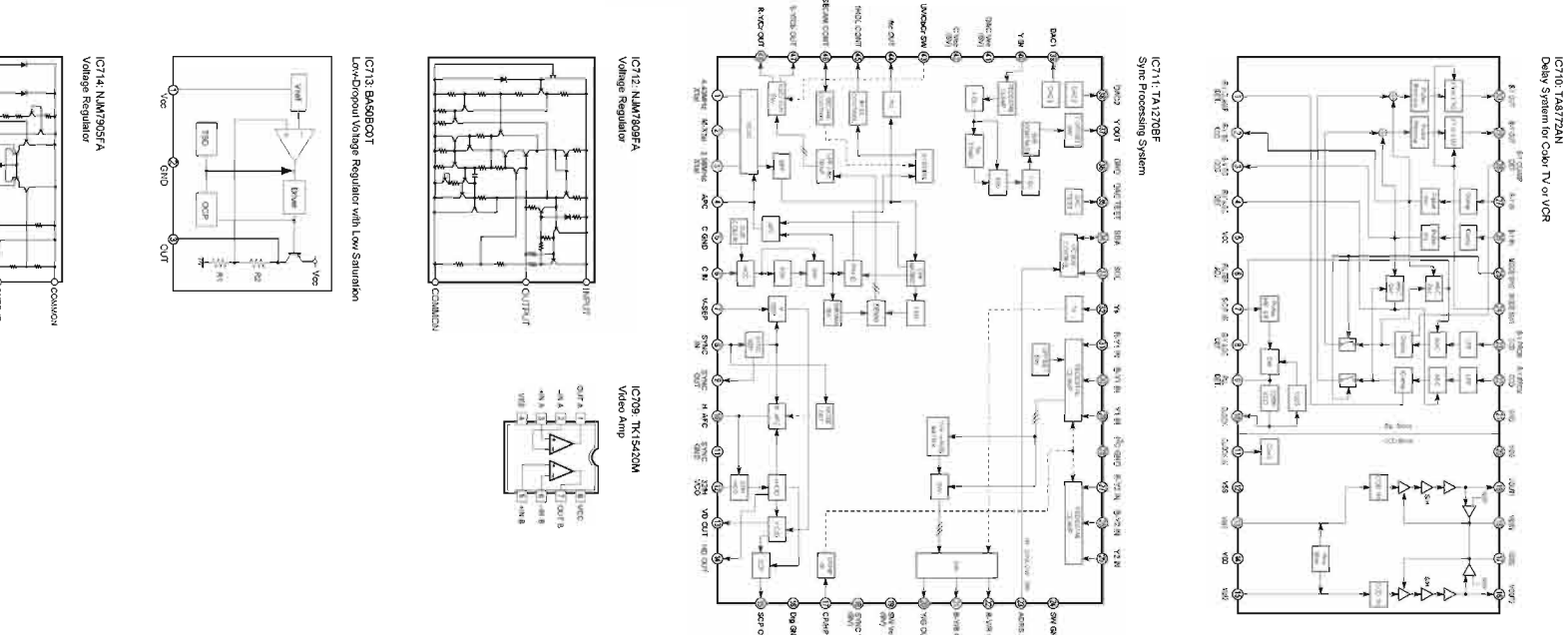

REVISION

NO.	REVISION	DATE	BY
1	INITIAL		
2	REVISION		
3	REVISION		
4	REVISION		
5	REVISION		
6	REVISION		
7	REVISION		
8	REVISION		
9	REVISION		
10	REVISION		

REVISION

NO.	REVISION	DATE	BY
1	INITIAL		
2	REVISION		
3	REVISION		
4	REVISION		
5	REVISION		
6	REVISION		
7	REVISION		
8	REVISION		
9	REVISION		
10	REVISION		

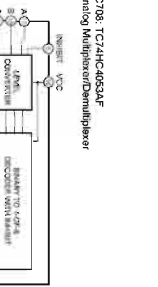
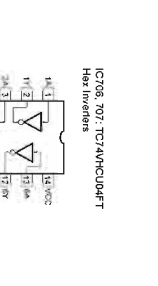
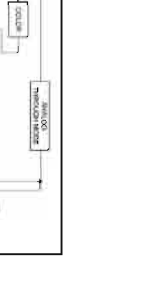
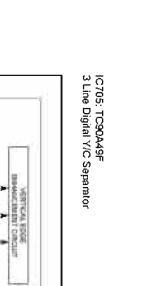
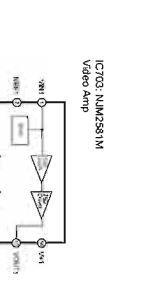

REVISION

NO.	REVISION	DATE	BY
1	INITIAL		
2	REVISION		
3	REVISION		
4	REVISION		
5	REVISION		
6	REVISION		
7	REVISION		
8	REVISION		
9	REVISION		
10	REVISION		

REVISION

NO.	REVISION	DATE	BY
1	INITIAL		
2	REVISION		
3	REVISION		
4	REVISION		
5	REVISION		
6	REVISION		
7	REVISION		
8	REVISION		
9	REVISION		
10	REVISION		

REVISION

NO.	REVISION	DATE	BY
1	INITIAL		
2	REVISION		
3	REVISION		
4	REVISION		
5	REVISION		
6	REVISION		
7	REVISION		
8	REVISION		
9	REVISION		
10	REVISION		

REVISION

NO.	REVISION	DATE	BY
1	INITIAL		
2	REVISION		
3	REVISION		
4	REVISION		
5	REVISION		
6	REVISION		
7	REVISION		
8	REVISION		
9	REVISION		
10	REVISION		

REVISION

NO.	REVISION	DATE	BY
1	INITIAL		
2	REVISION		
3	REVISION		
4	REVISION		
5	REVISION		
6	REVISION		
7	REVISION		
8	REVISION		
9	REVISION		
10	REVISION		

REVISION

NO.	REVISION	DATE	BY
1	INITIAL		
2	REVISION		
3	REVISION		
4	REVISION		
5	REVISION		
6	REVISION		
7	REVISION		
8	REVISION		
9	REVISION		
10	REVISION		

REVISION

NO.	REVISION	DATE	BY
1	INITIAL		
2	REVISION		
3	REVISION		
4	REVISION		
5	REVISION		
6	REVISION		
7	REVISION		
8	REVISION		
9	REVISION		
10	REVISION		

REVISION

NO.	REVISION	DATE	BY
1	INITIAL		
2	REVISION		
3	REVISION		
4	REVISION		
5	REVISION		
6	REVISION		
7	REVISION		
8	REVISION		
9	REVISION		
10	REVISION		

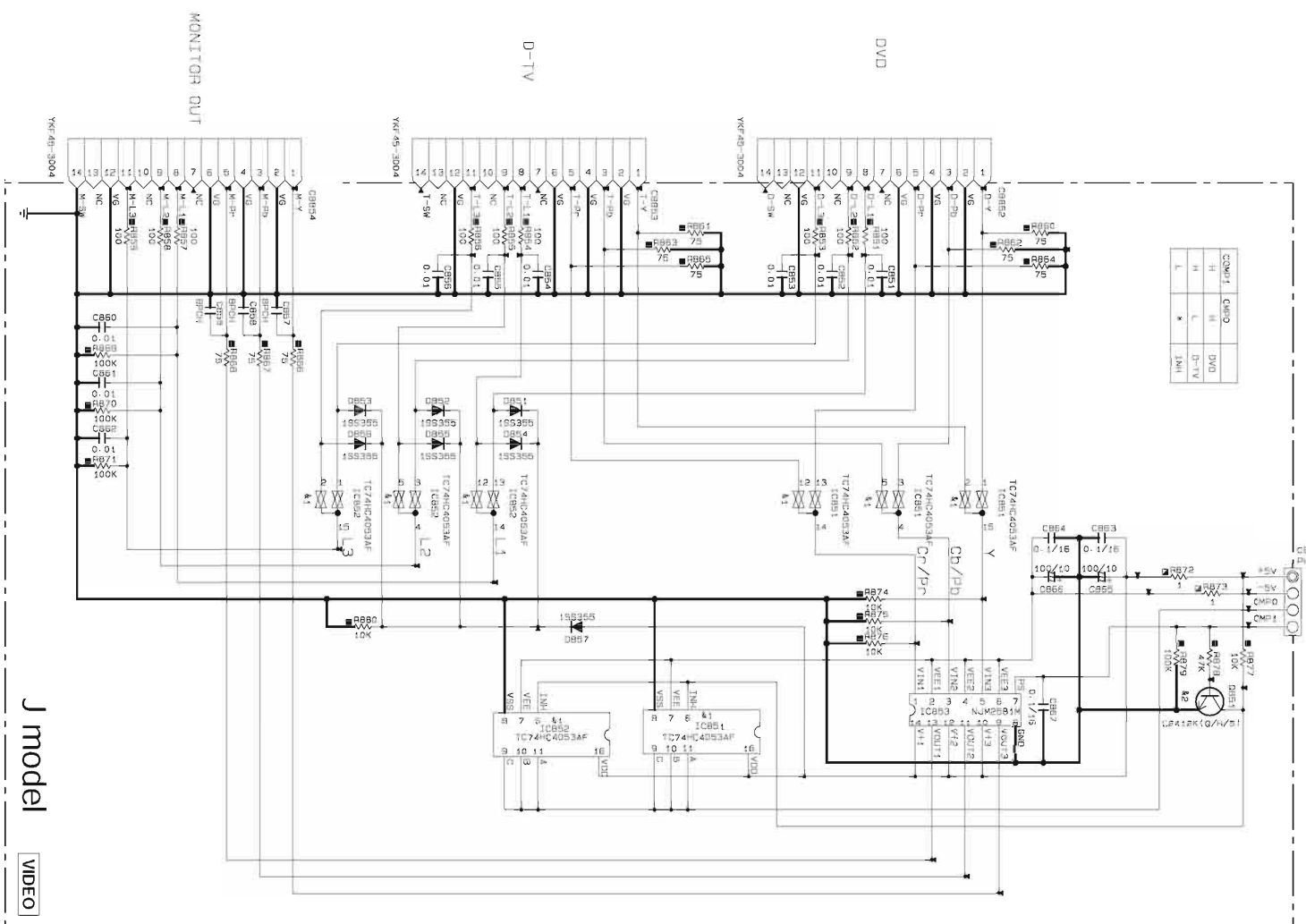

COMP1	COMP2
H	H
L	L
*	*

RESISTOR

REMARKS	PARTS NAME
<input checked="" type="checkbox"/>	CARBON FILM RESISTOR (P=51)
<input checked="" type="checkbox"/>	CARBON FILM RESISTOR (P=10)
<input checked="" type="checkbox"/>	METAL OXIDE FILM RESISTOR
<input checked="" type="checkbox"/>	METAL FILM RESISTOR
<input checked="" type="checkbox"/>	METAL PLATE RESISTOR
<input checked="" type="checkbox"/>	FILM PROOF CARBON FILM RESISTOR
<input checked="" type="checkbox"/>	CEMENT MOLDED RESISTOR
<input checked="" type="checkbox"/>	SEMI VARIABLE RESISTOR
<input checked="" type="checkbox"/>	CHIP RESISTOR

CAPACITOR

REMARKS	PARTS NAME
<input checked="" type="checkbox"/>	ELECTROLYTIC CAPACITOR
<input checked="" type="checkbox"/>	TANTALUM CAPACITOR
<input checked="" type="checkbox"/>	NO MARK CERAMIC TUBULAR CAPACITOR
<input checked="" type="checkbox"/>	NO MARK CERAMIC TUBULAR CAPACITOR
<input checked="" type="checkbox"/>	POLYESTER FILM CAPACITOR
<input checked="" type="checkbox"/>	POLYSTYRENE FILM CAPACITOR
<input checked="" type="checkbox"/>	MICA CAPACITOR
<input checked="" type="checkbox"/>	POLYPROPYLENE FILM CAPACITOR
<input checked="" type="checkbox"/>	SEMICONDUCTIVE CERAMIC CAPACITOR

Interchangeable parts at Manufacture-Stage

Mark	Reference Parts Number	Parts Name
K1	IC81-82	TC74HC003AF W74HC003AF
K2	DB81	C541K10V75I DB01A(D/75)

NOTICE (mod01)
 (J)..... JAPAN
 (U)..... U.S.A.
 (C)..... CANADA
 (R)..... GENERAL
 (T)..... CHINA
 (K)..... KOREA
 (A)..... AUSTRALIA
 (B)..... BRITISH
 (E)..... EUROPE
 (L)..... SINGAPORE
 (S)..... SOUTH EUROPE
 (V)..... TAIWAN

IC81-82: TC74HC003AF
 Analog Multiplexer Demultiplexer

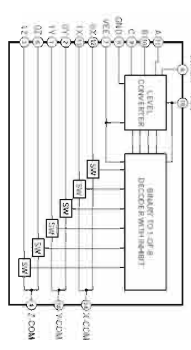

IC83: ALM252M
 Video Amp

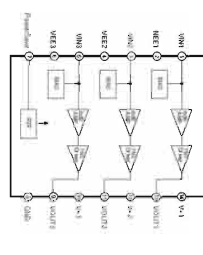

* All voltages are measured with a 100kΩ DC electronic voltmeter.
 * Components having special characteristics are marked A, and must be replaced with parts having specifications equal to those originally installed.
 * Schematic diagram is subject to change without notice.

* 電圧は、100kΩ DC電圧計で測定したものです。
 * 特別な特性を有する部品は、Aと表示されています。取替は、同等の規格が保証された部品、パーツにしてください。
 * 本図面は、仕様変更を伴う場合があります。変更なしと表示されている限り、変更されることなし。

J model VIDEO

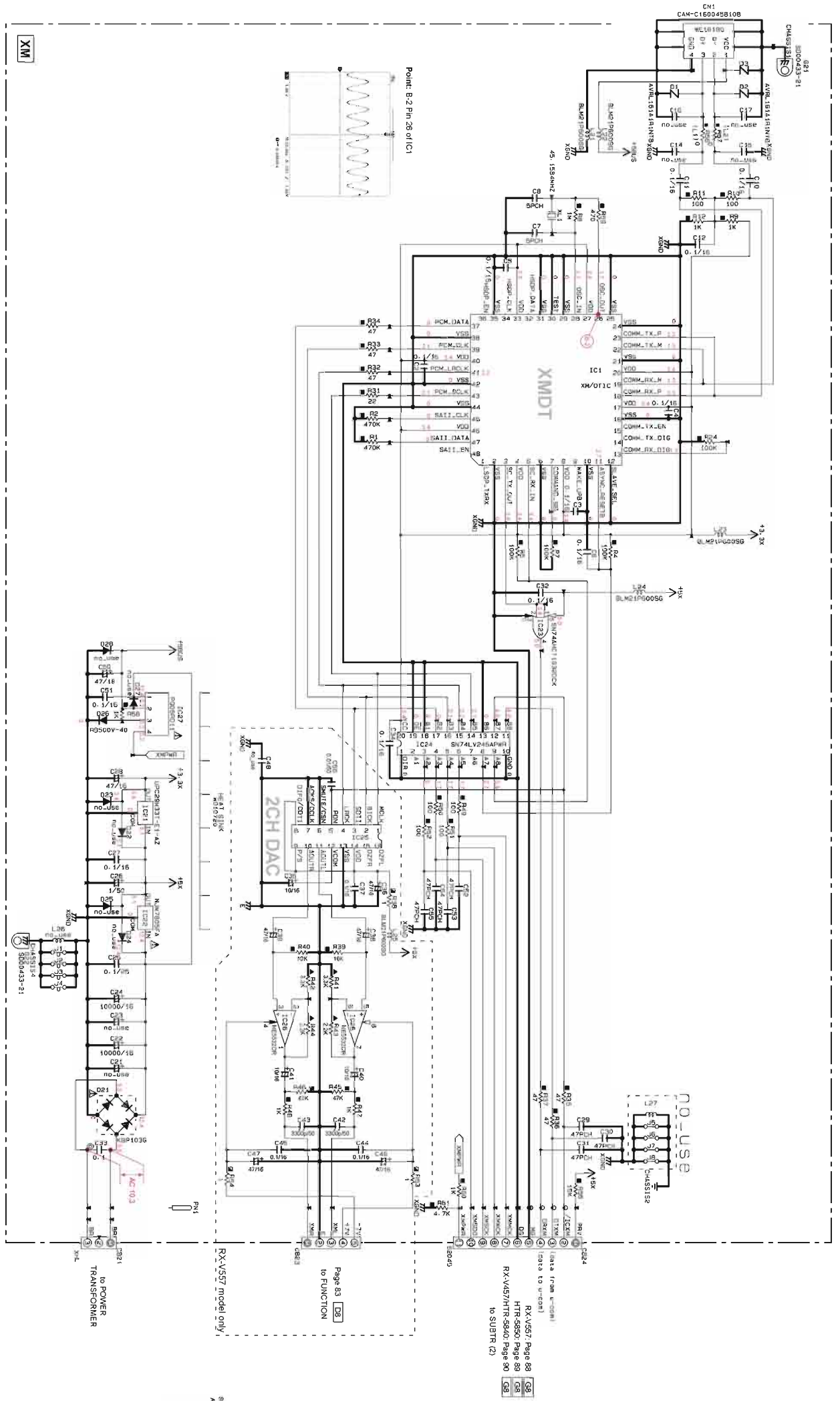

CAPACITOR

REMARKS	PART'S NAME	#
①	ELECTROLYTIC CAPACITOR	
②	TANTALUM CAPACITOR	
③	CERAMIC CAPACITOR	
④	GENERAL PURPOSE FILM CAPACITOR	
⑤	POLYESTER FILM CAPACITOR	
⑥	POLYSTYRENE FILM CAPACITOR	
⑦	MICA CAPACITOR	
⑧	POLYPROPYLENE FILM CAPACITOR	
⑨	SEMICONDUCTIVE CERAMIC CAPACITOR	
⑩	POLYBENZYLENE SULFIDE FILM CAPACITOR	

RESISTOR

REMARKS	PART'S NAME
①	CARBON FILM RESISTOR (P-5,1)
②	CARBON FILM RESISTOR (P-10)
③	METAL OXIDE FILM RESISTOR
④	METAL FILM RESISTOR
⑤	METAL PLATE RESISTOR
⑥	FINE PROOF CARBON FILM RESISTOR
⑦	CEMENT MONOLITHIC RESISTOR
⑧	SEMI VARIABLE RESISTOR
⑨	CHIP RESISTOR

NOTICE (model1)

(J)..... JAPAN
 (U)..... U.S.A
 (C)..... CANADA
 (P)..... GENERAL
 (1)..... CHINA
 (K)..... KOREA
 (A)..... AUSTRALIA
 (B)..... BRITISH
 (G)..... EUROPE
 (L)..... SINGAPORE
 (V)..... SOUTH EUROPE
 (E)..... TAIWAN

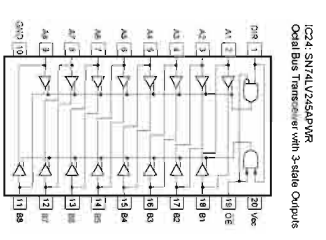
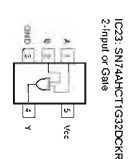
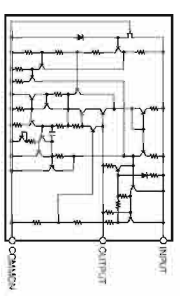
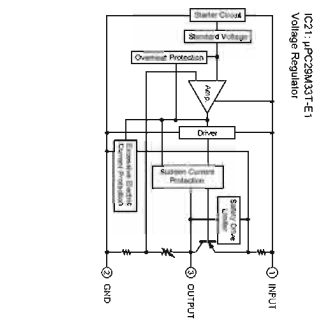
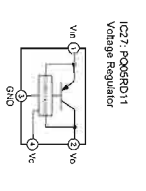
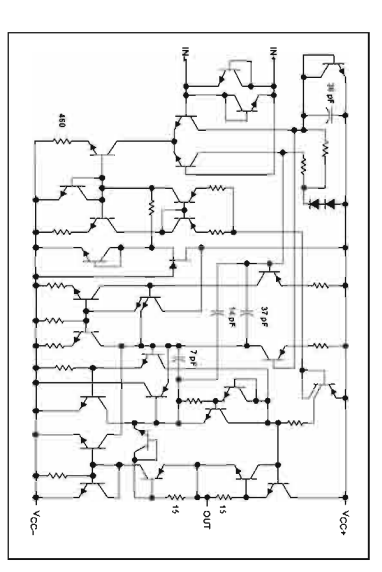
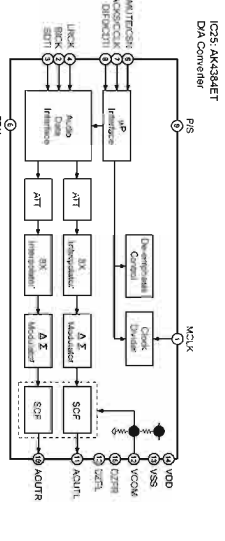

* All voltages are measured with a 10MΩV DC electronic volt meter.
 * Components having special characteristics are marked Δ, and must be replaced with parts having specifications equal to those originally installed.
 * Schematic diagram is subject to change without notice.
 * 電圧は、10MΩV DC電圧計で測定した値を示す。
 * 特殊な特性を有する部品はΔで示され、同等の規格品で交換しなければならない。
 * 回路図は変更される場合があります。ご了承ください。

PARTS LIST

■ ELECTRICAL PARTS

■ WARNING

- Components having special characteristics are marked \triangle and must be replaced with parts having specifications equal to those originally installed.
- \triangle 印のある部分は、安全確保部品を示しています。部品の交換が必要な場合、パーツリストに記載されている部品を使用してください。
- 部品価格ランクは、予告なく変更することがあります。

ABBREVIATIONS IN THIS LIST ARE AS FOLLOWS:

C.A.EL.CHP	: CHIP ALUMI.ELECTROLYTIC CAP	L.EMIT	: LIGHT EMITTING MODULE
C.CE	: CERAMIC CAP	LED.DSPLY	: LED DISPLAY
C.CE.ARRAY	: CERAMIC CAP ARRAY	LED.INFRD	: LED,INFRARED
C.CE.CHP	: CHIP CERAMIC CAP	MODUL.RF	: MODULATOR,RF
C.CE.ML	: MULTILAYER CERAMIC CAP	PHOT.CPL	: PHOTO COUPLER
C.CE.M.CHP	: CHIP MULTILAYER CERAMIC CAP	PHOT.INTR	: PHOTO INTERRUPTER
C.CE.SAFTY	: RECOGNIZED CERAMIC CAP	PHOT.RFLCT	: PHOTO REFLECTOR
C.CE.TUBLR	: CERAMIC TUBULAR CAP	PIN.TEST	: PIN,TEST POINT
C.CE.SMI	: SEMI CONDUCTIVE CERAMIC CAP	PLST.RIVET	: PLASTIC RIVET
C.EL	: ELECTROLYTIC CAP	R.ARRAY	: RESISTOR ARRAY
C.MICA	: MICA CAP	R.CAR.	: CARBON RESISTOR
C.ML.FLM	: MULTILAYER FILM CAP	R.CAR.CHP	: CHIP RESISTOR
C.MP	: METALLIZED PAPER CAP	R.CAR.FP	: FLAME PROOF CARBON RESISTOR
C.MYLAR	: MYLAR FILM CAP	R.FUS	: FUSABLE RESISTOR
C.MYLAR.ML	: MULTILAYER MYLAR FILM CAP	R.MTL.CHP	: CHIP METAL FILM RESISTOR
C.PAPER	: PAPER CAPACITOR	R.MTL.FLM	: METAL FILM RESISTOR
C.PLS	: POLYSTYRENE FILM CAP	R.MTL.OXD	: METAL OXIDE FILM RESISTOR
C.POL	: POLYESTER FILM CAP	R.MTL.PLAT	: METAL PLATE RESISTOR
C.POLY	: POLYETHYLENE FILM CAP	RSNR.CE	: CERAMIC RESONATOR
C.PP	: POLYPROPYLENE FILM CAP	RSNR.CRYS	: CRYSTAL RESONATOR
C.TNTL	: TANTALUM CAP	R.TW.CEM	: TWIN CEMENT FIXED RESISTOR
C.TNTL.CHP	: CHIP TANTALUM CAP	R.WW	: WIRE WOUND RESISTOR
C.TRIM	: TRIMMER CAP	SCR.BND.HD	: BIND HEAD B-TITE SCREW
CN	: CONNECTOR	SCR.BW.HD	: BW HEAD TAPPING SCREW
CN.BS.PIN	: CONNECTOR,BASE PIN	SCR.CUP	: CUP TITE SCREW
CN.CANNON	: CONNECTOR,CANNON	SCR.TERM	: SCREW TERMINAL
CN.DIN	: CONNECTOR,DIN	SCR.TR	: SCREW,TRANSISTOR
CN.FLAT	: CONNECTOR,FLAT CABLE	SUPRT.PCB	: SUPPORT,P.C.B.
CN.POST	: CONNECTOR,BASE POST	SURG.PRTCT	: SURGE PROTECTOR
COIL.MX.AM	: COIL,AM MIX	SW.TACT	: TACT SWITCH
COIL.AT.FM	: COIL,FM ANTENNA	SW.LEAF	: LEAF SWITCH
COIL.DT.FM	: COIL,FM DETECT	SW.LEVER	: LEVER SWITCH
COIL.MX.FM	: COIL,FM MIX	SW.MICRO	: MICRO SWITCH
COIL.OUTPT	: OUTPUT COIL	SW.PUSH	: PUSH SWITCH
DIOD.ARRAY	: DIODE ARRAY	SW.RT.ENC	: ROTARY ENCODER
DIODE.BRG	: DIODE BRIDGE	SW.RT.MTR	: ROTARY SWITCH WITH MOTOR
DIODE.CHP	: CHIP DIODE	SW.RT	: ROTARY SWITCH
DIODE.VAR	: VARACTOR DIODE	SW.SLIDE	: SLIDE SWITCH
DIOD.Z.CHP	: CHIP ZENER DIODE	TERM.SP	: SPEAKER TERMINAL
DIODE.ZENR	: ZENER DIODE	TERM.WRAP	: WRAPPING TERMINAL
DSCR.CE	: CERAMIC DISCRIMINATOR	THRMST.CHP	: CHIP THERMISTOR
FER.BEAD	: FERRITE BEADS	TR.CHP	: CHIP TRANSISTOR
FER.CORE	: FERRITE CORE	TR.DGT	: DIGITAL TRANSISTOR
FET.CHP	: CHIP FET	TR.DGT.CHP	: CHIP DIGITAL TRANSISTOR
FL.DSPLY	: FLUORESCENT DISPLAY	TRANS	: TRANSFORMER
FLTR.CE	: CERAMIC FILTER	TRANS.PULS	: PULSE TRANSFORMER
FLTR.COMB	: COMB FILTER MODULE	TRANS.PWR	: POWER TRANSFORMER ASS'Y
FLTR.LC.RF	: LC FILTER,EMI	TUNER.AM	: TUNER PACK,AM
GND.MTL	: GROUND PLATE	TUNER.FM	: TUNER PACK,FM
GND.TERM	: GROUND TERMINAL	TUNER.PK	: FRONT-ENDTUNER PACK
HOLDER.FUS	: FUSE HOLDER	VR	: ROTARY POTENTIOMETER
IC.PRTCT	: IC PROTECTOR	VR.MTR	: POTENTIOMETER WITH MOTOR
JUMPER.CN	: JUMPER CONNECTOR	VR.SW	: POTENTIOMETER WITH ROTARY SW
JUMPER.TST	: JUMPER,TEST POINT	VR.SLIDE	: SLIDE POTENTIOMETER
L.DTCT	: LIGHT DETECTING MODULE	VR.TRIM	: TRIMMER POTENTIOMETER

Note) Those parts marked with “#” are not included in the P.C.B. ass'y.

P.C.B. DSP

Schm Ref.	PART NO.	Description	Remarks	Markets	部 品 名	Rank	
*	WE592900	P. C. B.	DSP	557, 5850	JRTKABGEL	P C B D S P	
*	WE593000	P. C. B.	DSP	557, 5850	UC	P C B D S P	
*	WE593100	P. C. B.	DSP	457	J	P C B D S P	
*	WE593200	P. C. B.	DSP	457, 5840	UC	P C B D S P	
*	WE593300	P. C. B.	DSP	457, 5840	RTKABGEL	P C B D S P	
CB1	V7828500	SOCKET	18P TE TUC SERIES			コネクタースocket	
CB2	V0044800	CN. BS. PIN	18P			FFCコネクタ	01
CB11	LB919020	CN. BS. PIN	2P			ベース付ポスト	01
C1	UR238100	C. EL	100uF 16V			ケミコン	
C2	UR238100	C. EL	100uF 16V			ケミコン	
C12	UR837220	C. EL	22uF 16V	557, 5850		ケミコン	01
C12	UR837220	C. EL	22uF 16V	457, 5840	UCRTKABGEL	ケミコン	01
C15	UR837470	C. EL	47uF 16V			ケミコン	01
C36	UA654680	C. MYLAR	0.068uF 50V			マイラーコン	02
C40	UA653100	C. MYLAR	1000pF 50V			マイラーコン	03
C50	UR838100	C. EL	100uF 16V			ケミコン	01
C53	UR838100	C. EL	100uF 16V			ケミコン	01
C54	UR837100	C. EL	10uF 16V			ケミコン	01
C55	UR238100	C. EL	100uF 16V			ケミコン	
C65	UR238100	C. EL	100uF 16V			ケミコン	
C76	UR238100	C. EL	100uF 16V			ケミコン	
C81	UR238100	C. EL	100uF 16V			ケミコン	
C94	UR837470	C. EL	47uF 16V			ケミコン	01
C124	UR838100	C. EL	100uF 16V			ケミコン	01
C126	UR838100	C. EL	100uF 16V			ケミコン	01
C131	UR818470	C. EL	470uF 6.3V			ケミコン	01
C145	UR866220	C. EL	2.2uF 50V			ケミコン	01
C152	UR837100	C. EL	10uF 16V			ケミコン	01
C153	UR837100	C. EL	10uF 16V			ケミコン	01
C154	UR837100	C. EL	10uF 16V			ケミコン	01
C156	UR837100	C. EL	10uF 16V			ケミコン	01
C157	UR837100	C. EL	10uF 16V			ケミコン	01
C158	UR837100	C. EL	10uF 16V			ケミコン	01
C159	UR837100	C. EL	10uF 16V			ケミコン	01
C162	UR837100	C. EL	10uF 16V			ケミコン	01
C163	UR837100	C. EL	10uF 16V			ケミコン	01
C164	UA652680	C. MYLAR	680pF 50V			マイラーコン	01
C165	UA654470	C. MYLAR	0.047uF 50V			マイラーコン	01
C166	UA652680	C. MYLAR	680pF 50V			マイラーコン	01
C168	UA652680	C. MYLAR	680pF 50V			マイラーコン	01
C169	UA652680	C. MYLAR	680pF 50V			マイラーコン	01
C177	UA652100	C. MYLAR	100pF 50V			マイラーコン	01
C178	UR837470	C. EL	47uF 16V			ケミコン	01
C179	UA652100	C. MYLAR	100pF 50V			マイラーコン	01
C180	UA652100	C. MYLAR	100pF 50V			マイラーコン	01
C181	UA652100	C. MYLAR	100pF 50V			マイラーコン	01
C183	UA653390	C. MYLAR	3900pF 50V			マイラーコン	01
C186	UR837100	C. EL	10uF 16V			ケミコン	01
C187	UR837100	C. EL	10uF 16V			ケミコン	01

* New Parts * 新規部品

P.C.B. DSP

Schm Ref.	PART NO.	Description	Remarks	Markets	部 品 名	Rank
C188	UR837100	C. EL 10uF 16V			ケミコン	01
C190	UR837100	C. EL 10uF 16V			ケミコン	01
C191	UR837100	C. EL 10uF 16V			ケミコン	01
C194	UR837100	C. EL 10uF 16V			ケミコン	01
C195	UR837100	C. EL 10uF 16V			ケミコン	01
C198	VE326000	C. MYLAR. ML 0.1uF 50V			積層マイラーコン	01
C199	VE326000	C. MYLAR. ML 0.1uF 50V			積層マイラーコン	01
C200	VE326000	C. MYLAR. ML 0.1uF 50V			積層マイラーコン	01
C201	VE326000	C. MYLAR. ML 0.1uF 50V			積層マイラーコン	01
C202	VE326000	C. MYLAR. ML 0.1uF 50V			積層マイラーコン	01
C203	VE326000	C. MYLAR. ML 0.1uF 50V			積層マイラーコン	01
C206	UR837470	C. EL 47uF 16V			ケミコン	01
C207	UR837470	C. EL 47uF 16V			ケミコン	01
C208	UR837470	C. EL 47uF 16V			ケミコン	01
C209	UR837470	C. EL 47uF 16V			ケミコン	01
C210	UR837470	C. EL 47uF 16V			ケミコン	01
C211	UR837470	C. EL 47uF 16V			ケミコン	01
D3	VT332900	DIODE 1SS355			ダイオード	01
D8	VT332900	DIODE 1SS355			ダイオード	01
D9	WB081800	DIODE SB01-05Q			ショットキダイオード	
D10	WB081800	DIODE SB01-05Q			ショットキダイオード	
D11	WB081800	DIODE SB01-05Q			ショットキダイオード	
D12	WB081800	DIODE SB01-05Q			ショットキダイオード	
D13	VT332900	DIODE 1SS355			ダイオード	01
IC1	X3936A00	IC SN74LVU04APWR	557, 5850		ロジックIC	
IC1	X3936A00	IC SN74LVU04APWR	457, 5840	UCRTKABGEL	ロジックIC	
IC2	X5444A00	IC LC89057W-VF4D-E			IC	
IC3	X3018A00	IC SN74AHCT00PWR NAND			ロジックIC TSOP	01
IC5	X6137A00	IC D60YA003BPYP225			IC	
IC6	X2590B00	IC W9816G6CH-7 SDRAM			メモリIC 16M	06
IC7	X6123A00	IC SN74LV157APWR		UC	ロジックIC	
IC8	X6261A00	IC MBM29LV400BC-70PFT			メモリIC 4M	06
IC9	XS534A00	IC NJM78M05DL1A (TE1)			電源IC TO-252	02
IC10	X3693A00	IC SN74LV245APWR TRAN			ロジックIC TSSOP	
IC11	X6051A00	IC UPC29M33T-E1-AZ			電源IC	
IC12	X3833A00	IC SN74AHC1G08DCKR			ロジックIC SOP	01
IC13	X5945A00	IC PQ012FZ01ZPH			電源IC	
IC14	X6123A00	IC SN74LV157APWR			ロジックIC	
IC16	X3807A00	IC AK4628VQ			IC	
IC18	X3505A00	IC NJM2068MD-TE2			アンプIC SOP	02
IC19	X5482A00	IC NE5532DR OP AMP			アンプIC SOP	
IC20	X5482A00	IC NE5532DR OP AMP			アンプIC SOP	
IC21	X3505A00	IC NJM2068MD-TE2			アンプIC SOP	02
IC22	X3824A00	IC SN74AHCT08PWR			ロジックIC	01
IC26	X2080A00	IC SN74AHCT1G32DCKR			ロジックIC	01
PJ1	V4483900	JACK. PIN 1P YKC21-3895	557, 5850		ピンジャック	
PJ1	V4483900	JACK. PIN 1P YKC21-3895	457, 5840	UCRTKABGEL	ピンジャック	
R18	HV753100	R. CAR. FP 1Ω 1/4W			不燃化カーボン抵抗	01
R40	V8070000	R. MTL. FLM 1Ω 1W			金属被膜抵抗	01

* New Parts * 新規部品

P.C.B. DSP & P.C.B. FUNCTION

Schm Ref.	PART NO.	Description	Remarks	Markets	部 品 名	Rank
R63	V8070000	R. MTL. FLM 1Ω 1W			金属被膜抵抗	01
R104	VU224000	R. MTL. FLM 0.22Ω 1W			金属被膜抵抗	01
R105	HV753100	R. CAR. FP 1Ω 1/4W			不燃化カーボン抵抗	01
R111	HV753100	R. CAR. FP 1Ω 1/4W			不燃化カーボン抵抗	01
R133	V8070100	R. MTL. FLM 2.2Ω 1W			金属被膜抵抗	01
R149	V8070100	R. MTL. FLM 2.2Ω 1W			金属被膜抵抗	01
R193	V8070600	R. MTL. FLM 33Ω 1W			金属被膜抵抗	01
ST1	V4040500	SCR. TERM M3			スクリーノターミナル	01
U1	WB001600	CN. PHOT. SN 1P GP1FA553TZ	557, 5850		光ファイバリンク	
U1	WB001600	CN. PHOT. SN 1P GP1FA553TZ	457	J	光ファイバリンク	
U2	WB001400	CN. PHOT. SN 1P GP1FA553RZ	557, 5850		光ファイバ受信器	04
U2	WB001400	CN. PHOT. SN 1P GP1FA553RZ	457	J	光ファイバ受信器	04
U3	WB001400	CN. PHOT. SN 1P GP1FA553RZ			光ファイバ受信器	04
U4	WB001400	CN. PHOT. SN 1P GP1FA553RZ			光ファイバ受信器	04
XL1	V3625700	RSNR. CRYST 24.576MHz			水晶振動子	03
*	WE593600	P. C. B. FUNCTION	557	JRTKL	P C B ファンクション	
*	WE593700	P. C. B. FUNCTION	557	UC	P C B ファンクション	
*	WE593800	P. C. B. FUNCTION	557	ABGE	P C B ファンクション	
*	WE593600	P. C. B. FUNCTION	5850, 457, 5840		P C B ファンクション	
CB301	V7826600	CN 16P TE TUC SERIES			コネクタプラグ	01
CB303	V7828700	SOCKET 20P SE TUC SERIES			コネクタソケット	01
CB305	VP573800	CN. BS. PIN 18P			F F Cコネクタ	01
CB306	VB858700	CN. BS. PIN 8P			ベースピン	01
CB307	VK026600	CN. BS. PIN 7P			ワイヤトラップ	01
CB308	VM923600	CN. BS. PIN 13P			F F Cコネクタ	01
CB309	VB858400	CN. BS. PIN 5P			ベースピン	01
C307	UA652220	C. MYLAR 220pF 50V			マイラーコン	01
C308	UA652220	C. MYLAR 220pF 50V			マイラーコン	01
C309	UA652220	C. MYLAR 220pF 50V			マイラーコン	01
C310	UA652220	C. MYLAR 220pF 50V			マイラーコン	01
C311	FG651470	C. CE 47pF 50V			セラコン	01
C312	FG651470	C. CE 47pF 50V			セラコン	01
C313	UR837100	C. EL 10uF 16V			ケミコン	01
C314	UR837100	C. EL 10uF 16V			ケミコン	01
C315	UR837100	C. EL 10uF 16V			ケミコン	01
C316	UR837100	C. EL 10uF 16V			ケミコン	01
C317	UR837100	C. EL 10uF 16V			ケミコン	01
C318	VE326300	C. MYLAR. ML 0.18uF 50V			積層マイラーコン	01
C319	VE326300	C. MYLAR. ML 0.18uF 50V			積層マイラーコン	01
C320	UA653470	C. MYLAR 4700pF 50V			マイラーコン	01
C321	UR837100	C. EL 10uF 16V			ケミコン	01
C322	UR837100	C. EL 10uF 16V			ケミコン	01
C323	UR837100	C. EL 10uF 16V			ケミコン	01
C324	UR837100	C. EL 10uF 16V			ケミコン	01
C325	VE326200	C. MYLAR. ML 0.15uF 50V			積層マイラーコン	01
C326	VE326200	C. MYLAR. ML 0.15uF 50V			積層マイラーコン	01

* New Parts * 新規部品

P.C.B. FUNCTION

Schm Ref.	PART NO.	Description	Remarks	Markets	部 品 名	Rank
C327	UA653470	C. MYLAR 4700pF 50V			マイラーコン	01
C330	UR837100	C. EL 10uF 16V			ケミコン	01
C331	UR837100	C. EL 10uF 16V			ケミコン	01
C332	UA652100	C. MYLAR 100pF 50V			マイラーコン	01
C333	UA652100	C. MYLAR 100pF 50V			マイラーコン	01
C334	UR837100	C. EL 10uF 16V			ケミコン	01
C335	UR837100	C. EL 10uF 16V			ケミコン	01
C336	UR867470	C. EL 47uF 50V			ケミコン	01
C337	UR867470	C. EL 47uF 50V			ケミコン	01
C338	UR837100	C. EL 10uF 16V			ケミコン	01
C339	UA652150	C. MYLAR 150pF 50V			マイラーコン	01
C340	UR837100	C. EL 10uF 16V			ケミコン	01
C341	UR837100	C. EL 10uF 16V			ケミコン	01
C342	UR837100	C. EL 10uF 16V			ケミコン	01
C343	UR837100	C. EL 10uF 16V			ケミコン	01
C344	UR837100	C. EL 10uF 16V			ケミコン	01
C347	UR867470	C. EL 47uF 50V			ケミコン	01
C348	UR867470	C. EL 47uF 50V			ケミコン	01
C349	UR837100	C. EL 10uF 16V			ケミコン	01
C350	UR837100	C. EL 10uF 16V			ケミコン	01
C355	UR837100	C. EL 10uF 16V			ケミコン	01
C356	UR837100	C. EL 10uF 16V			ケミコン	01
C361	UR837100	C. EL 10uF 16V			ケミコン	01
C362	UR837100	C. EL 10uF 16V			ケミコン	01
C365	UR839100	C. EL 1000uF 16V			ケミコン	01
C366	UR839100	C. EL 1000uF 16V			ケミコン	01
C367	UR837100	C. EL 10uF 16V			ケミコン	01
C368	UR837100	C. EL 10uF 16V			ケミコン	01
C369	UR837100	C. EL 10uF 16V			ケミコン	01
C370	UR837100	C. EL 10uF 16V			ケミコン	01
C371	UA652100	C. MYLAR 100pF 50V			マイラーコン	01
C372	UA652100	C. MYLAR 100pF 50V			マイラーコン	01
C373	UA652680	C. MYLAR 680pF 50V			マイラーコン	01
C374	UA652680	C. MYLAR 680pF 50V			マイラーコン	01
C377	UR837470	C. EL 47uF 16V			ケミコン	01
C378	UR837470	C. EL 47uF 16V			ケミコン	01
D301	VU994300	DIODE. ZENR MA8075-H 7.7V			ツェナーダイオード	
D302	VU994300	DIODE. ZENR MA8075-H 7.7V			ツェナーダイオード	
D303	VV307700	DIODE 1N4002S			ダイオード	01
D304	VV307700	DIODE 1N4002S			ダイオード	01
IC301	X5092A00	IC BD3816K1			IC	
IC302	X3547A00	IC BD3841FS	557	UCABGE	IC	06
IC303	X3505A00	IC NJM2068MD-TE2			アンプIC SOP	02
IC304	X3505A00	IC NJM2068MD-TE2			アンプIC SOP	02
IC305	XP844A00	IC NJM4556AL			IC	02
IC306	X3505A00	IC NJM2068MD-TE2			アンプIC SOP	02
PJ301	V7190400	JACK. PIN 6P			ピンジャック	03
PJ302	V7046800	JACK. PIN 6P MSP-246V1-01N1			ピンジャック	
PN301	V9637500	PIN L=70 #18			スタイルピン	

* New Parts * 新規部品

P.C.B. FUNCTION & P.C.B. OPERATION

Schm Ref.	PART NO.	Description	Remarks	Markets	部 品 名	Rank
Q301	VD303700	TR	2SC3326 A,B		トランジスタ	
Q302	VD303700	TR	2SC3326 A,B		トランジスタ	
Q303	VD303700	TR	2SC3326 A,B		トランジスタ	
Q304	VD303700	TR	2SC3326 A,B		トランジスタ	
Q305	VD303700	TR	2SC3326 A,B		トランジスタ	
Q306	VD303700	TR	2SC3326 A,B		トランジスタ	
Q307	iC181510	TR	2SC1815 Y		トランジスタ 2 S C	01
Q308	iA101510	TR	2SA1015 Y		トランジスタ 2 S A	01
Q309	VD303700	TR	2SC3326 A,B		トランジスタ	
Q310	VD303700	TR	2SC3326 A,B		トランジスタ	
Q311	VZ725900	TR	2SD1938F S,T		トランジスタ	
Q312	VZ725900	TR	2SD1938F S,T		トランジスタ	
R336	HF356560	R. CAR	5.6KΩ 1/2W		カーボン抵抗	
R337	HF356560	R. CAR	5.6KΩ 1/2W		カーボン抵抗	
R338	HF356150	R. CAR	1.5KΩ 1/2W		カーボン抵抗	
R339	HF356150	R. CAR	1.5KΩ 1/2W		カーボン抵抗	
R342	HF353220	R. CAR	2.2Ω 1/2W		カーボン抵抗	
R343	HF353220	R. CAR	2.2Ω 1/2W		カーボン抵抗	
R352	HF356100	R. CAR	1KΩ 1/2W		カーボン抵抗	
R356	HF356100	R. CAR	1KΩ 1/2W		カーボン抵抗	
R357	HF356100	R. CAR	1KΩ 1/2W		カーボン抵抗	
R374	HV755220	R. CAR. FP	220Ω 1/4W		不燃化カーボン抵抗	01
R375	HV755150	R. CAR. FP	150Ω 1/4W		不燃化カーボン抵抗	01
R382	HV755100	R. CAR. FP	100Ω 1/4W		不燃化カーボン抵抗	01
R383	HV755100	R. CAR. FP	100Ω 1/4W		不燃化カーボン抵抗	01
R384	HF355100	R. CAR	100Ω 1/2W		カーボン抵抗	
R385	HF355100	R. CAR	100Ω 1/2W		カーボン抵抗	
R396	HF353220	R. CAR	2.2Ω 1/2W		カーボン抵抗	
R397	HF353220	R. CAR	2.2Ω 1/2W		カーボン抵抗	
R411	HV754470	R. CAR. FP	47Ω 1/4W		不燃化カーボン抵抗	01
R412	HV754470	R. CAR. FP	47Ω 1/4W		不燃化カーボン抵抗	01
*	WE594000	P. C. B.	OPERATION	557	P C B オペレーション	
*	WE594100	P. C. B.	OPERATION	5850, 457, 5840	P C B オペレーション	
CB801	VQ045100	CN. BS. PIN	21P		F F C コネクター	02
CB863	LB919020	CN. BS. PIN	2P		ベース付ポスト	01
CB871	VB858400	CN. BS. PIN	5P	557	ベースピン	01
C808	UM397100	C. EL	10uF 16V		ケミコン	01
C811	UM388330	C. EL	330uF 6.3V		ケミコン	01
C822	UM417100	C. EL	10uF 50V	557	ケミコン	01
C871	UA654100	C. MYLAR	0.01uF 50V		マイラーコン	01
C872	UA653100	C. MYLAR	1000pF 50V		マイラーコン	03
C874	UA654100	C. MYLAR	0.01uF 50V		マイラーコン	01
C875	UA654100	C. MYLAR	0.01uF 50V		マイラーコン	01
D802	V2598200	LED	SIR-505ST	557	L E D	
D803	VU171500	DIODE. ZENR	UDZ 3.6BTE-17 3.6V		ツェナーダイオード	01
D804	VU171500	DIODE. ZENR	UDZ 3.6BTE-17 3.6V		ツェナーダイオード	01

* New Parts * 新規部品

P.C.B. OPERATION

Schm Ref.	PART NO.	Description	Remarks	Markets	部 品 名	Rank
D805	VT332900	DIODE	1SS355		ダイオード	01
D806	VT332900	DIODE	1SS355	557	ダイオード	01
D807	VT332900	DIODE	1SS355	557	ダイオード	01
D808	VT332900	DIODE	1SS355	557	ダイオード	01
D871	VU995000	DIODE. ZENR	MA8091-M 9.1V		ツェナーダイオード	
D872	VT332900	DIODE	1SS355		ダイオード	01
D873	VT332900	DIODE	1SS355		ダイオード	01
D881	VT332900	DIODE	1SS355		ダイオード	01
D882	VT332900	DIODE	1SS355		ダイオード	01
D883	VT332900	DIODE	1SS355		ダイオード	01
D884	VT332900	DIODE	1SS355		ダイオード	01
IC801	X6386A00	IC	M66003-0131FP		IC	
JK871	V9408200	JACK. PHONE	MSJ-064-05B GR		ホーンジャック	03
PJ881	V7190100	JACK. PIN	3P		ピンジャック	
PN801	V9637500	PIN	L=70 #18		スタイルピン	
PN802	V9637500	PIN	L=70 #18	557	スタイルピン	
PN861	V9637500	PIN	L=70 #18	5850, 457, 5840	スタイルピン	
PN871	V9637500	PIN	L=70 #18	557	スタイルピン	
PN881	V9637500	PIN	L=70 #18		スタイルピン	
Q801	VV556400	TR	2SC2412K Q, R, S		トランジスタ	01
Q802	VV556400	TR	2SC2412K Q, R, S		トランジスタ	01
Q803	VV556400	TR	2SC2412K Q, R, S		トランジスタ	01
Q804	VV556400	TR	2SC2412K Q, R, S		トランジスタ	01
Q805	VV556400	TR	2SC2412K Q, R, S		トランジスタ	01
Q806	VV556400	TR	2SC2412K Q, R, S		トランジスタ	01
Q807	VV556400	TR	2SC2412K Q, R, S	5850, 457, 5840	トランジスタ	01
Q808	VV556400	TR	2SC2412K Q, R, S	557	トランジスタ	01
ST871	V4040500	SCR. TERM	M3	557	スクリュー/ターミナル	01
ST871	WA246200	SCR. TERM	3.5	5850, 457, 5840	スクリューターミナル	
ST881	WA246200	SCR. TERM	3.5		スクリューターミナル	
ST882	WA246200	SCR. TERM	3.5	5850, 457, 5840	スクリューターミナル	
SW801	V9597100	SW. RT. ENC	EC12E2460802		ロータリーエンコーダ	04
SW802	V9266400	SW. RT. ENC	XREB12105PVB25F		ロータリーエンコーダ	02
SW803	V9266400	SW. RT. ENC	XREB12105PVB25F	557	ロータリーエンコーダ	02
SW803	WD483100	SW. TACT	SKRGAAD010	5850, 457, 5840	タクト SW	01
SW804	WD483100	SW. TACT	SKRGAAD010		タクト SW	01
SW805	WD483100	SW. TACT	SKRGAAD010		タクト SW	01
SW806	WD483100	SW. TACT	SKRGAAD010		タクト SW	01
SW807	WD483100	SW. TACT	SKRGAAD010		タクト SW	01
SW808	WD483100	SW. TACT	SKRGAAD010		タクト SW	01
SW809	WD483100	SW. TACT	SKRGAAD010		タクト SW	01
SW810	WD483100	SW. TACT	SKRGAAD010		タクト SW	01
SW811	WD483100	SW. TACT	SKRGAAD010		タクト SW	01
SW812	WD483100	SW. TACT	SKRGAAD010		タクト SW	01
SW813	WD483100	SW. TACT	SKRGAAD010	5850, 457, 5840	タクト SW	01
SW814	WD483100	SW. TACT	SKRGAAD010		タクト SW	01
SW815	WD483100	SW. TACT	SKRGAAD010	5850, 457, 5840	タクト SW	01
SW816	WD483100	SW. TACT	SKRGAAD010		タクト SW	01
SW817	WD483100	SW. TACT	SKRGAAD010		タクト SW	01

* New Parts * 新規部品

P.C.B. OPERATION & P.C.B. MAIN

Schm Ref.	PART NO.	Description	Remarks	Markets	部 品 名	Rank
SW818	WD483100	SW. TACT	SKRGAAD010		タクト SW	01
SW819	WD483100	SW. TACT	SKRGAAD010		タクト SW	01
SW823	WD483100	SW. TACT	SKRGAAD010	5850, 457, 5840	タクト SW	01
SW824	WD483100	SW. TACT	SKRGAAD010		タクト SW	01
SW861	WD483100	SW. TACT	SKRGAAD010		タクト SW	01
SW866	WD483100	SW. TACT	SKRGAAD010	5850, 457, 5840	タクト SW	01
SW867	WD483100	SW. TACT	SKRGAAD010	5850, 457, 5840	タクト SW	01
U801	WC746300	L. DTCT	RPM7138-H9		リモコン受光ユニット	
V801	WE289300	FL. DSPLY	17-BT-24GNK		蛍光表示管	
	V6880300	SHEET			シート/FL	
	V6007100	SPACER. FL	4.6/10/32		スペーサ FL	
*	WE588000	P. C. B.	MAIN	557, 5850	JUCRTA	P C B メイン
*	WE588100	P. C. B.	MAIN	557, 5850	KBGEL	P C B メイン
*	WE588200	P. C. B.	MAIN	457, 5840	JUCRTA	P C B メイン
*	WE588300	P. C. B.	MAIN	457, 5840	KBGEL	P C B メイン
CB121	V7825600	CN	6P TE TUC SERIES		コネクタプラグ	
CB122	VM973500	CN. BS. PIN	17P		FFCコネクタ	01
CB123	WB127100	CN. BS. PIN	3P TE XH		ベースツキポスト	
CB127	LB932060	CN. BS. PIN	6P		ベースポスト	01
C1	UR297100	C. EL	10uF 100V		ケミコン	
C2	UR297100	C. EL	10uF 100V		ケミコン	
C3	UT952150	C. PP	150pF 100V		PPコン	
C4	UR267470	C. EL	47uF 50V		ケミコン	
C5	UT952150	C. PP	150pF 100V		PPコン	
C6	UT952150	C. PP	150pF 100V		PPコン	
C7	UR267470	C. EL	47uF 50V		ケミコン	
C8	UT952150	C. PP	150pF 100V		PPコン	
C9	UT952150	C. PP	150pF 100V		PPコン	
C10	UR267470	C. EL	47uF 50V		ケミコン	
C11	UT952150	C. PP	150pF 100V		PPコン	
C12	UT952150	C. PP	150pF 100V		PPコン	
C13	UR267470	C. EL	47uF 50V		ケミコン	
C14	UT952150	C. PP	150pF 100V		PPコン	
C15	UT952150	C. PP	150pF 100V		PPコン	
C16	UR267470	C. EL	47uF 50V		ケミコン	
C17	UT952150	C. PP	150pF 100V		PPコン	
C18	UT952150	C. PP	150pF 100V		PPコン	
C19	UR267470	C. EL	47uF 50V		ケミコン	
C20	UT952150	C. PP	150pF 100V		PPコン	
C23	UT954220	C. PP	0.022uF 100V		PPコン	
C24	UT954220	C. PP	0.022uF 100V		PPコン	
C25	VR324700	C. MYLAR	0.022uF 100V		マイラーコン	
C26	VR324700	C. MYLAR	0.022uF 100V		マイラーコン	
C27	VR324700	C. MYLAR	0.022uF 100V		マイラーコン	
C28	UT954220	C. PP	0.022uF 100V		PPコン	
C29	UR818100	C. EL	100uF 6.3V		ケミコン	01

* New Parts * 新規部品

P.C.B. MAIN

Schm Ref.	PART NO.	Description	Remarks	Markets	部 品 名	Rank
	C30	UR866470 C. EL	4.7uF 50V		ケミコン	01
△	C31	UR297100 C. EL	10uF 100V		ケミコン	
△	C32	UR297100 C. EL	10uF 100V		ケミコン	
	C116	WA747600 C. MYLAR	1000pF 100V		マイラーコン	
	C117	WA747600 C. MYLAR	1000pF 100V		マイラーコン	
	C118	WA747600 C. MYLAR	1000pF 100V		マイラーコン	
	C119	WA747600 C. MYLAR	1000pF 100V		マイラーコン	
	C120	UR857470 C. EL	47uF 35V		ケミコン	01
△	C121	UR866470 C. EL	4.7uF 50V		ケミコン	01
* △	C122	WE515700 C. EL	10000uF 71V	557, 5850	ケミコン	
* △	C122	WE586800 C. EL	8200uF 71V	457, 5840	ケミコン	
* △	C123	WE515700 C. EL	10000uF 71V	557, 5850	ケミコン	
* △	C123	WE586800 C. EL	8200uF 71V	457, 5840	ケミコン	
	C124	UR858100 C. EL	100uF 35V		ケミコン	01
	C125	VR325400 C. MYLAR	0.1uF 100V		マイラーコン	01
	C126	VR325400 C. MYLAR	0.1uF 100V		マイラーコン	01
	C128	UR268220 C. EL	220uF 50V		ケミコン	
	C129	UR268100 C. EL	100uF 50V		ケミコン	
	C130	UA654100 C. MYLAR	0.01uF 50V		KBGEL マイラーコン	01
	C131	UA654100 C. MYLAR	0.01uF 50V		KBGEL マイラーコン	01
	C132	VR325400 C. MYLAR	0.1uF 100V		マイラーコン	01
△	C133	VR324900 C. MYLAR	0.1uF 100V		マイラーコン	01
	C134	UA654100 C. MYLAR	0.01uF 50V		KBGEL マイラーコン	01
	C135	UA654100 C. MYLAR	0.01uF 50V		KBGEL マイラーコン	01
	C136	UA654100 C. MYLAR	0.01uF 50V		KBGEL マイラーコン	01
	C137	UA654100 C. MYLAR	0.01uF 50V		KBGEL マイラーコン	01
	C138	UA653470 C. MYLAR	4700pF 50V		KBGEL マイラーコン	01
	C139	UA653470 C. MYLAR	4700pF 50V		KBGEL マイラーコン	01
	C140	UA653470 C. MYLAR	4700pF 50V		KBGEL マイラーコン	01
	C141	UA653470 C. MYLAR	4700pF 50V		KBGEL マイラーコン	01
	C142	UA654220 C. MYLAR	0.022uF 50V		マイラーコン	01
	C143	UA654220 C. MYLAR	0.022uF 50V		マイラーコン	01
	C144	UA654220 C. MYLAR	0.022uF 50V		マイラーコン	01
	C145	UA654220 C. MYLAR	0.022uF 50V		マイラーコン	01
	C252	UR297100 C. EL	10uF 100V		ケミコン	
	C253	UR237100 C. EL	10uF 16V		ケミコン	
	C254	UR237100 C. EL	10uF 16V		ケミコン	
	C256	WE100900 C. PP	220pF 630V		PPコン	
	C257	UA654220 C. MYLAR	0.022uF 50V		マイラーコン	01
	C258	UA654220 C. MYLAR	0.022uF 50V		マイラーコン	01
	C259	WE100900 C. PP	220pF 630V		PPコン	
	D3	VD631600 DIODE	1SS133, 176		ダイオード	01
	D4	VD631600 DIODE	1SS133, 176		ダイオード	01
	D5	VD631600 DIODE	1SS133, 176		ダイオード	01
	D6	VD631600 DIODE	1SS133, 176		ダイオード	01
	D7	VD631600 DIODE	1SS133, 176		ダイオード	01
	D8	VD631600 DIODE	1SS133, 176		ダイオード	01
	D9	VD631600 DIODE	1SS133, 176		ダイオード	01
	D2	VD631600 DIODE	1SS133, 176		ダイオード	01

* New Parts * 新規部品

P.C.B. MAIN

Schm Ref.	PART NO.	Description	Remarks	Markets	部 品 名	Rank
D10	VD631600	DIODE	1SS133, 176		ダイオード	01
D11	VD631600	DIODE	1SS133, 176		ダイオード	01
D12	VD631600	DIODE	1SS133, 176		ダイオード	01
D13	VD631600	DIODE	1SS133, 176		ダイオード	01
D14	VD631600	DIODE	1SS133, 176		ダイオード	01
D15	VN008700	DIODE	1SS270A		ダイオード	01
D16	VN008700	DIODE	1SS270A		ダイオード	01
D17	VN008700	DIODE	1SS270A		ダイオード	01
D18	VN008700	DIODE	1SS270A		ダイオード	01
D19	VN008700	DIODE	1SS270A		ダイオード	01
D20	VN008700	DIODE	1SS270A		ダイオード	01
D22	VN008700	DIODE	1SS270A		ダイオード	01
D23	VN008700	DIODE	1SS270A		ダイオード	01
D24	VN008700	DIODE	1SS270A		ダイオード	01
D25	VN008700	DIODE	1SS270A		ダイオード	01
D26	VN008700	DIODE	1SS270A		ダイオード	01
D27	VN008700	DIODE	1SS270A		ダイオード	01
D120	VG442900	DIODE. ZENR	MTZJ27B 27V		ツェナーダイオード	01
D122	VG443200	DIODE. ZENR	MTZJ30A 30V		ツェナーダイオード	01
D123	VG442900	DIODE. ZENR	MTZJ27B 27V		ツェナーダイオード	01
D125	VG442900	DIODE. ZENR	MTZJ27B 27V		ツェナーダイオード	01
D127	VG442900	DIODE. ZENR	MTZJ27B 27V		ツェナーダイオード	01
D129	VG442900	DIODE. ZENR	MTZJ27B 27V		ツェナーダイオード	01
△ D133	WA653200	DIODE. BRG	TS6P03G 6.0A 200V		ダイオードブリッジ	04
D134	VG442900	DIODE. ZENR	MTZJ27B 27V		ツェナーダイオード	01
△ D141	VS997800	DIODE	1T2		ダイオード	01
△ D142	VS997800	DIODE	1T2		ダイオード	01
△ D143	VS997800	DIODE	1T2		ダイオード	01
△ D144	VS997800	DIODE	1T2		ダイオード	01
D251	VD631600	DIODE	1SS133, 176		ダイオード	01
D252	VG440700	DIODE. ZENR	MTZJ15A 15V		ツェナーダイオード	
D253	VG435500	DIODE. ZENR	MTZJ2.4B 2.4V		ツェナーダイオード	01
D254	VG435500	DIODE. ZENR	MTZJ2.4B 2.4V		ツェナーダイオード	01
G122	V5995800	PLATE. GND			アースプレート	
PN1	V9637500	PIN	L=70 #18		スタイルピン	
PN4	V9637500	PIN	L=70 #18		スタイルピン	
Q1	VC614000	TR	2SB1274 Q, R, S		トランジスタ	02
Q2	iA101510	TR	2SA1015 Y		トランジスタ 2SA	01
△ Q3	VK432900	TR	2SD1915F S, T		トランジスタ	01
Q4	VR325600	TR	2SC2229 O, Y		トランジスタ	01
△ Q5	VK432900	TR	2SD1915F S, T		トランジスタ	01
Q6	VR325600	TR	2SC2229 O, Y		トランジスタ	01
△ Q7	VK432900	TR	2SD1915F S, T		トランジスタ	01
△ Q8	VK432900	TR	2SD1915F S, T		トランジスタ	01
Q9	VR325600	TR	2SC2229 O, Y		トランジスタ	01
△ Q10	VK432900	TR	2SD1915F S, T		トランジスタ	01
Q11	VR325600	TR	2SC2229 O, Y		トランジスタ	01
△ Q12	VK432900	TR	2SD1915F S, T		トランジスタ	01
Q13	VR325600	TR	2SC2229 O, Y		トランジスタ	01

* New Parts * 新規部品

P.C.B. MAIN

Schm Ref.	PART NO.	Description	Remarks	Markets	部 品 名	Rank
	Q15	VR325600 TR	2SC2229 0, Y		トランジスタ	01
△	Q16A	iX630850 TR	2SA1695 0, P, Y		トランジスタ	04
△	Q16C	iX630860 TR	2SC4468 0, P, Y		トランジスタ	04
△	Q18A	iX630850 TR	2SA1695 0, P, Y		トランジスタ	04
△	Q18C	iX630860 TR	2SC4468 0, P, Y		トランジスタ	04
△	Q20A	iX630850 TR	2SA1695 0, P, Y		トランジスタ	04
△	Q20C	iX630860 TR	2SC4468 0, P, Y		トランジスタ	04
△	Q22A	iX630850 TR	2SA1695 0, P, Y		トランジスタ	04
△	Q22C	iX630860 TR	2SC4468 0, P, Y		トランジスタ	04
△	Q24A	iX630850 TR	2SA1695 0, P, Y		トランジスタ	04
△	Q24C	iX630860 TR	2SC4468 0, P, Y		トランジスタ	04
△	Q26A	iX630850 TR	2SA1695 0, P, Y		トランジスタ	04
△	Q26C	iX630860 TR	2SC4468 0, P, Y		トランジスタ	04
	Q28	WC398400 TR	2SC2N5551C-AT		トランジスタ	
	Q29	WC398400 TR	2SC2N5551C-AT		トランジスタ	
	Q30	WC398400 TR	2SC2N5551C-AT		トランジスタ	
	Q31	WC398400 TR	2SC2N5551C-AT		トランジスタ	
	Q32	WC398400 TR	2SC2N5551C-AT		トランジスタ	
	Q33	WC398400 TR	2SC2N5551C-AT		トランジスタ	
	Q34	WC397700 TR	2SA2N5401C-AT		トランジスタ	
	Q35	iC181510 TR	2SC1815 Y		トランジスタ 2 S C	01
△	Q120	iA101510 TR	2SA1015 Y		トランジスタ 2 S A	01
	Q121	VP872700 TR	2SC4488 S, T		トランジスタ	01
	Q123	VP872700 TR	2SC4488 S, T		トランジスタ	01
	Q124	VP872700 TR	2SC4488 S, T		トランジスタ	01
△	Q125	VP872700 TR	2SC4488 S, T		トランジスタ	01
	Q126	VP872700 TR	2SC4488 S, T		トランジスタ	01
	Q127	VP872700 TR	2SC4488 S, T		トランジスタ	01
	Q251	iC181510 TR	2SC1815 Y		トランジスタ 2 S C	01
△	Q252	VC614000 TR	2SB1274 Q, R, S		トランジスタ	02
	Q253	VP872600 TR	2SA1708 S, T		トランジスタ	01
	Q254	iC181510 TR	2SC1815 Y		トランジスタ 2 S C	01
	Q256	V4096100 TR	2SC4614 S, T		トランジスタ	02
	Q257	V4096100 TR	2SC4614 S, T		トランジスタ	02
	Q258	V4096100 TR	2SC4614 S, T		トランジスタ	02
△	Q259	V4096100 TR	2SC4614 S, T		トランジスタ	02
	Q260	V4096100 TR	2SC4614 S, T		トランジスタ	02
	Q261	V4096100 TR	2SC4614 S, T		トランジスタ	02
	Q262	V4096000 TR	2SA1770 S, T		トランジスタ	03
	Q263	V4096000 TR	2SA1770 S, T		トランジスタ	03
△	Q264	V4096000 TR	2SA1770 S, T		トランジスタ	03
△	Q265	V4096000 TR	2SA1770 S, T		トランジスタ	03
	Q266	V4096000 TR	2SA1770 S, T		トランジスタ	03
	Q267	V4096000 TR	2SA1770 S, T		トランジスタ	03
	R9	HV754100 R. CAR. FP	10Ω 1/4W		不燃化カーボン抵抗	01
	R10	HL006270 R. MTL. OXD	2.7KΩ 1/2W		酸化金属被膜抵抗	
	R11	HL005470 R. MTL. OXD	470Ω 1/2W		酸化金属被膜抵抗	
	R12	HL005820 R. MTL. OXD	820Ω 1/2W		酸化金属被膜抵抗	
	R13	HV755100 R. CAR. FP	100Ω 1/4W		不燃化カーボン抵抗	01

* New Parts * 新規部品

P.C.B. MAIN

Schm Ref.	PART NO.	Description	Remarks	Markets	部 品 名	Rank
R14	HL006270	R. MTL. OXD 2.7KΩ 1/2W			酸化金属被膜抵抗	
R15	HL005470	R. MTL. OXD 470Ω 1/2W			酸化金属被膜抵抗	
R16	HL005820	R. MTL. OXD 820Ω 1/2W			酸化金属被膜抵抗	
R17	HV755100	R. CAR. FP 100Ω 1/4W			不燃化カーボン抵抗	01
R18	HL006270	R. MTL. OXD 2.7KΩ 1/2W			酸化金属被膜抵抗	
R19	HL005470	R. MTL. OXD 470Ω 1/2W			酸化金属被膜抵抗	
R20	HL005820	R. MTL. OXD 820Ω 1/2W			酸化金属被膜抵抗	
R21	HL006270	R. MTL. OXD 2.7KΩ 1/2W			酸化金属被膜抵抗	
R22	HL005470	R. MTL. OXD 470Ω 1/2W			酸化金属被膜抵抗	
R23	HL005820	R. MTL. OXD 820Ω 1/2W			酸化金属被膜抵抗	
R24	HV755100	R. CAR. FP 100Ω 1/4W			不燃化カーボン抵抗	01
R25	HL006270	R. MTL. OXD 2.7KΩ 1/2W			酸化金属被膜抵抗	
R26	HL005470	R. MTL. OXD 470Ω 1/2W			酸化金属被膜抵抗	
R27	HL005820	R. MTL. OXD 820Ω 1/2W			酸化金属被膜抵抗	
R28	HV755100	R. CAR. FP 100Ω 1/4W			不燃化カーボン抵抗	01
R29	HL006270	R. MTL. OXD 2.7KΩ 1/2W			酸化金属被膜抵抗	
R30	HL005470	R. MTL. OXD 470Ω 1/2W			酸化金属被膜抵抗	
R31	HL005820	R. MTL. OXD 820Ω 1/2W			酸化金属被膜抵抗	
R32	HV755100	R. CAR. FP 100Ω 1/4W			不燃化カーボン抵抗	01
R34	HL006100	R. MTL. OXD 1KΩ 1/2W			酸化金属被膜抵抗	
R35	HL006100	R. MTL. OXD 1KΩ 1/2W			酸化金属被膜抵抗	
R36	HL006100	R. MTL. OXD 1KΩ 1/2W			酸化金属被膜抵抗	
R37	HL006100	R. MTL. OXD 1KΩ 1/2W			酸化金属被膜抵抗	
R38	HL006100	R. MTL. OXD 1KΩ 1/2W			酸化金属被膜抵抗	
R39	HL006100	R. MTL. OXD 1KΩ 1/2W			酸化金属被膜抵抗	
R40	HV755100	R. CAR. FP 100Ω 1/4W			不燃化カーボン抵抗	01
R41	V8072100	R. MTL. OXD 5.6KΩ 1W			酸化金属被膜抵抗	
△ R45	V3873200	R. WW 0.22Ω 3W			セメント抵抗	02
△ R46	V3873200	R. WW 0.22Ω 3W			セメント抵抗	02
△ R47	WB279900	R. WW RGC55C 0.22+0.22			セメント抵抗	
△ R48	WB279900	R. WW RGC55C 0.22+0.22			セメント抵抗	
△ R49	WB279900	R. WW RGC55C 0.22+0.22			セメント抵抗	
△ R50	V3873200	R. WW 0.22Ω 3W			セメント抵抗	02
△ R71	V8070300	R. MTL. FLM 10Ω 1W			金属被膜抵抗	
△ R72	V8070300	R. MTL. FLM 10Ω 1W			金属被膜抵抗	
△ R73	V8070300	R. MTL. FLM 10Ω 1W			金属被膜抵抗	
△ R74	V8070300	R. MTL. FLM 10Ω 1W			金属被膜抵抗	
△ R75	V8070300	R. MTL. FLM 10Ω 1W			金属被膜抵抗	
△ R76	V8070300	R. MTL. FLM 10Ω 1W			金属被膜抵抗	
△ R108	HV753100	R. CAR. FP 1Ω 1/4W			不燃化カーボン抵抗	01
R118	HV755180	R. CAR. FP 180Ω 1/4W			不燃化カーボン抵抗	01
R123	HV755180	R. CAR. FP 180Ω 1/4W			不燃化カーボン抵抗	01
R124	HV755180	R. CAR. FP 180Ω 1/4W			不燃化カーボン抵抗	01
△ R125	HV755100	R. CAR. FP 100Ω 1/4W			不燃化カーボン抵抗	01
△ R126	HV756100	R. CAR. FP 1KΩ 1/4W			不燃化カーボン抵抗	01
R131	HV755180	R. CAR. FP 180Ω 1/4W			不燃化カーボン抵抗	01
R136	HV755180	R. CAR. FP 180Ω 1/4W			不燃化カーボン抵抗	01
R139	HV755180	R. CAR. FP 180Ω 1/4W			不燃化カーボン抵抗	01
R168	HV753470	R. CAR. FP 4.7Ω 1/4W			不燃化カーボン抵抗	01

* New Parts * 新規部品

P.C.B. MAIN

Schm Ref.	PART NO.	Description	Remarks	Markets	部 品 名	Rank
	R169	HV753470 R. CAR. FP	4.7Ω 1/4W		不燃化カーボン抵抗	01
△	R170	HV753100 R. CAR. FP	1Ω 1/4W		不燃化カーボン抵抗	01
△	R171	HV753100 R. CAR. FP	1Ω 1/4W		不燃化カーボン抵抗	01
	R172	HV753470 R. CAR. FP	4.7Ω 1/4W		不燃化カーボン抵抗	01
	R173	HV753470 R. CAR. FP	4.7Ω 1/4W		不燃化カーボン抵抗	01
	R210	V8072000 R. MTL. OXD	4.7KΩ 1W		酸化金属被膜抵抗	
	R251	HV756470 R. CAR. FP	4.7KΩ 1/4W		不燃化カーボン抵抗	01
	R256	HV756100 R. CAR. FP	1KΩ 1/4W		不燃化カーボン抵抗	01
	R264	HV754100 R. CAR. FP	10Ω 1/4W		不燃化カーボン抵抗	01
	R265	HV754100 R. CAR. FP	10Ω 1/4W		不燃化カーボン抵抗	01
	R266	HV753470 R. CAR. FP	4.7Ω 1/4W		不燃化カーボン抵抗	01
	R267	HV753470 R. CAR. FP	4.7Ω 1/4W		不燃化カーボン抵抗	01
	R268	HV753470 R. CAR. FP	4.7Ω 1/4W		不燃化カーボン抵抗	01
	R269	HV753470 R. CAR. FP	4.7Ω 1/4W		不燃化カーボン抵抗	01
	R270	HV753470 R. CAR. FP	4.7Ω 1/4W		不燃化カーボン抵抗	01
△	R271	HV753470 R. CAR. FP	4.7Ω 1/4W		不燃化カーボン抵抗	01
	R272	HV753470 R. CAR. FP	4.7Ω 1/4W		不燃化カーボン抵抗	01
	R273	HV753470 R. CAR. FP	4.7Ω 1/4W		不燃化カーボン抵抗	01
	R274	HV753470 R. CAR. FP	4.7Ω 1/4W		不燃化カーボン抵抗	01
	R275	HV753470 R. CAR. FP	4.7Ω 1/4W		不燃化カーボン抵抗	01
	R276	HV753470 R. CAR. FP	4.7Ω 1/4W		不燃化カーボン抵抗	01
	R277	HV753470 R. CAR. FP	4.7Ω 1/4W		不燃化カーボン抵抗	01
	R278	HV755100 R. CAR. FP	100Ω 1/4W		不燃化カーボン抵抗	01
	R279	HV755100 R. CAR. FP	100Ω 1/4W		不燃化カーボン抵抗	01
	R280	HV755100 R. CAR. FP	100Ω 1/4W		不燃化カーボン抵抗	01
	R281	HV755100 R. CAR. FP	100Ω 1/4W		不燃化カーボン抵抗	01
	R282	HV755100 R. CAR. FP	100Ω 1/4W		不燃化カーボン抵抗	01
	R283	HV755100 R. CAR. FP	100Ω 1/4W		不燃化カーボン抵抗	01
	R284	VP939700 R. MTL. FLM	4.7Ω 1W		金属被膜抵抗	01
	R291	HV753470 R. CAR. FP	4.7Ω 1/4W		不燃化カーボン抵抗	01
	R292	HV753470 R. CAR. FP	4.7Ω 1/4W		不燃化カーボン抵抗	01
	R293	VP939700 R. MTL. FLM	4.7Ω 1W		金属被膜抵抗	01
	R294	HV755100 R. CAR. FP	100Ω 1/4W		不燃化カーボン抵抗	01
	R295	HV755100 R. CAR. FP	100Ω 1/4W		不燃化カーボン抵抗	01
△	R296	HV755100 R. CAR. FP	100Ω 1/4W		不燃化カーボン抵抗	01
△	R297	HV755100 R. CAR. FP	100Ω 1/4W		不燃化カーボン抵抗	01
	R298	HV755100 R. CAR. FP	100Ω 1/4W		不燃化カーボン抵抗	01
	R299	HV755100 R. CAR. FP	100Ω 1/4W		不燃化カーボン抵抗	01
	RY121	V5966300 RELAY	DS24D2-0S(M)		リレー 24V	05
	RY122	V5966300 RELAY	DS24D2-0S(M)		リレー 24V	05
	RY123	V5178900 RELAY	DC DQ24D1-0S(M)		リレー 24V	
	RY124	V5966300 RELAY	DS24D2-0S(M)		リレー 24V	05
	RY125	V5966300 RELAY	DS24D2-0S(M)		リレー 24V	05
*	RY126	WE648700 RELAY	DC DH24D2-0-0		リレー 24V	
	ST121	V4040500 SCR. TERM	M3		スクリュー/ターミナル	01
	TE120	WC631900 TERM. SP	LTS0810-1017FM	JUCRTA	スピーカターミナル	06
*	TE120	WD477500 TERM. SP	LTS0810-1015FM	KBGEL	スピーカターミナル	
	TE121	WC631900 TERM. SP	LTS0810-1017FM	JUCRTA	スピーカターミナル	06
*	TE121	WD477500 TERM. SP	LTS0810-1015FM	KBGEL	スピーカターミナル	

* New Parts * 新規部品

P.C.B. MAIN & P.C.B. POWER

Schm Ref.	PART NO.	Description	Remarks	Markets	部 品 名	Rank
*	WE774200	SCR. BND. HD	3x10 MFZN2W3		バインドBタイトネジ	
*	WE588700	P. C. B.	POWER	557, 5850	P C B パワー	
*	WE588800	P. C. B.	POWER	457, 5840	P C B パワー	
CB351	VM923600	CN. BS. PIN	13P		F F Cコネクター	01
CB352	VK026700	CN. BS. PIN	8P		ワイヤートラップ	01
CB353	VB858300	CN. BS. PIN	4P		コネクタベースポスト	01
CB354	LB919070	CN. BS. PIN	7P		ベース付ポスト	01
CB355	LB918030	CN. BS. PIN	3P		ベース付ポスト	01
CB359	VK026700	CN. BS. PIN	8P		ワイヤートラップ	01
C301	UR237100	C. EL	10uF 16V		ケミコン	
C302	UR837100	C. EL	10uF 16V		ケミコン	01
C303	UR237100	C. EL	10uF 16V		ケミコン	
C304	UR237100	C. EL	10uF 16V		ケミコン	
C305	UR837100	C. EL	10uF 16V		ケミコン	01
C306	UT952100	C. PP	100pF 100V		P P コン	
C307	UT952220	C. PP	220pF 100V		P P コン	
C308	UT952100	C. PP	100pF 100V		P P コン	
C309	UT952220	C. PP	220pF 100V		P P コン	
C310	UA652100	C. MYLAR	100pF 50V		マイラーコン	01
C311	UA652220	C. MYLAR	220pF 50V		マイラーコン	01
C312	UA652100	C. MYLAR	100pF 50V		マイラーコン	01
C313	UA652220	C. MYLAR	220pF 50V		マイラーコン	01
C314	UT952100	C. PP	100pF 100V		P P コン	
C315	UT952220	C. PP	220pF 100V		P P コン	
C316	UT953330	C. PP	3300pF 100V		P P コン	
C317	UT953330	C. PP	3300pF 100V		P P コン	
C318	UA653330	C. MYLAR	3300pF 50V		マイラーコン	01
C319	UA653330	C. MYLAR	3300pF 50V		マイラーコン	01
C320	UT953330	C. PP	3300pF 100V		P P コン	
C321	UR268100	C. EL	100uF 50V		ケミコン	
C322	UR268100	C. EL	100uF 50V		ケミコン	
C323	UR837470	C. EL	47uF 16V		ケミコン	01
C324	UR837470	C. EL	47uF 16V		ケミコン	01
C325	UR268100	C. EL	100uF 50V		ケミコン	
C326	WA970300	C. CE	22pF 500V		セラコン (C H)	
C327	FU451220	C. MI CA	22pF 500V		マイカコン	01
C328	FU451220	C. MI CA	22pF 500V		マイカコン	01
C329	WA970300	C. CE	22pF 500V		セラコン (C H)	
C330	FU451220	C. MI CA	22pF 500V		マイカコン	01
C331	VJ599100	C. CE. TUBLR	0.1uF 50V		円筒セラコン	01
C332	UR266100	C. EL	1uF 50V		ケミコン	
C333	UR266100	C. EL	1uF 50V		ケミコン	
C334	VR325400	C. MYLAR	0.1uF 50V		マイラーコン	01
C337	UR837100	C. EL	10uF 16V		ケミコン	01
C340	UA652100	C. MYLAR	100pF 50V		マイラーコン	01
C341	UA652220	C. MYLAR	220pF 50V		マイラーコン	01

* New Parts * 新規部品

P.C.B. POWER

Schm Ref.	PART NO.	Description	Remarks	Markets	部 品 名	Rank
C342	UR266100	C. EL 1uF 50V			ケミコン	
C343	UR266100	C. EL 1uF 50V	457,5840		ケミコン	
C346	UA653330	C. MYLAR 3300pF 50V			マイラーコン	01
C347	UR837470	C. EL 47uF 16V			ケミコン	01
C349	WA970300	C. CE 22pF 500V			セラコン (C H)	
C350	UR238100	C. EL 100uF 16V			ケミコン	
C353	UR23A100	C. EL 10000uF 16V			ケミコン	
C357	UR23A100	C. EL 10000uF 16V			ケミコン	
C358	UR23A100	C. EL 10000uF 16V			ケミコン	
C359	UR23A100	C. EL 10000uF 16V			ケミコン	
C360	UR249680	C. EL 6800uF 25V			ケミコン	
C361	UR249220	C. EL 2200uF 25V			ケミコン	
C365	VR325200	C. MYLAR 0.022uF 100V			マイラーコン	
C366	VR325200	C. MYLAR 0.022uF 100V			マイラーコン	
C367	VR325400	C. MYLAR 0.1uF 100V			マイラーコン	
C368	VR325400	C. MYLAR 0.1uF 100V			マイラーコン	
C370	UT952220	C. PP 220pF 100V			PPコン	
C371	UR238100	C. EL 100uF 16V			ケミコン	
D301	VD631600	DIODE 1SS133,176			ダイオード	01
D302	VD631600	DIODE 1SS133,176			ダイオード	01
△ D312	WA653100	DIODE. BRG KBP103G 1.0A 200V			ダイオードブリッジ	02
△ D313	VN011300	DIODE. BRG D3SBA20 4A 200V			ダイオード	03
△ IC301	X0515A00	IC LM61CIZ THERMAL			電源IC	03
△ IC302	XJ608A00	IC NJM7812FA			IC	02
△ IC303	XD343A00	IC NJM79M12FA			IC	03
△ IC304	XJ607A00	IC NJM7805FA 5V			IC	02
△ IC305	XE436A00	IC NJM79M05FA	457,5840		IC	03
△ IC306	X6248A00	IC NJM2388F33			電源IC	
PN2	V9637500	PIN L=70 #18			スタイルピン	
PN3	V9637500	PIN L=70 #18			スタイルピン	
PN301	V9637500	PIN L=70 #18			スタイルピン	
PN302	V9637500	PIN L=70 #18			スタイルピン	
PN303	V9637500	PIN L=70 #18			スタイルピン	
PN304	V9637500	PIN L=70 #18			スタイルピン	
PN305	V9637500	PIN L=70 #18			スタイルピン	
Q301	VP883100	TR 2SC1890A D,E			トランジスタ	01
Q302	VP883100	TR 2SC1890A D,E			トランジスタ	01
Q303	VP883100	TR 2SC1890A D,E			トランジスタ	01
Q304	VP883100	TR 2SC1890A D,E			トランジスタ	01
Q305	VP883100	TR 2SC1890A D,E			トランジスタ	01
Q306	VP883100	TR 2SC1890A D,E			トランジスタ	01
Q307	VP883100	TR 2SC1890A D,E			トランジスタ	01
Q308	VP883100	TR 2SC1890A D,E			トランジスタ	01
Q309	VP883100	TR 2SC1890A D,E			トランジスタ	01
Q310	VP883100	TR 2SC1890A D,E			トランジスタ	01
Q311	V3966800	TR 2SA949 0,Y			トランジスタ	02
Q312	V3966800	TR 2SA949 0,Y			トランジスタ	02
Q313	V3966800	TR 2SA949 0,Y			トランジスタ	02
Q314	V3966800	TR 2SA949 0,Y			トランジスタ	02

* New Parts * 新規部品

P.C.B. POWER & P.C.B. SUBTRANS

Schm Ref.	PART NO.	Description	Remarks	Markets	部 品 名	Rank
Q315	V3966800	TR	2SA949 0, Y		トランジスタ	02
Q323	VP883100	TR	2SC1890A D, E		トランジスタ	01
Q325	VP883100	TR	2SC1890A D, E		トランジスタ	01
Q327	V3966800	TR	2SA949 0, Y		トランジスタ	02
R306	HF356100	R. CAR	1KΩ 1/2W		カーボン抵抗	
R307	HF356100	R. CAR	1KΩ 1/2W		カーボン抵抗	
R310	HF356100	R. CAR	1KΩ 1/2W		カーボン抵抗	
R331	HF355330	R. CAR	330Ω 1/2W		カーボン抵抗	
R332	HF355330	R. CAR	330Ω 1/2W		カーボン抵抗	
R335	HF355330	R. CAR	330Ω 1/2W		カーボン抵抗	
R336	HF356120	R. CAR	1.2KΩ 1/2W		カーボン抵抗	
R337	HF356120	R. CAR	1.2KΩ 1/2W		カーボン抵抗	
R340	HF356120	R. CAR	1.2KΩ 1/2W		カーボン抵抗	
R342	HF357330	R. CAR	33KΩ 1/2W		カーボン抵抗	
R343	HF357330	R. CAR	33KΩ 1/2W		カーボン抵抗	
R345	HF357330	R. CAR	33KΩ 1/2W		カーボン抵抗	
R346	HV755100	R. CAR. FP	100Ω 1/4W		不燃化カーボン抵抗	01
R347	HV755100	R. CAR. FP	100Ω 1/4W		不燃化カーボン抵抗	01
R348	HV755100	R. CAR. FP	100Ω 1/4W		不燃化カーボン抵抗	01
R349	HV755100	R. CAR. FP	100Ω 1/4W		不燃化カーボン抵抗	01
R350	HV755100	R. CAR. FP	100Ω 1/4W		不燃化カーボン抵抗	01
R353	HF355470	R. CAR	470Ω 1/2W		カーボン抵抗	
R354	HF355470	R. CAR	470Ω 1/2W		カーボン抵抗	
R355	HF355470	R. CAR	470Ω 1/2W		カーボン抵抗	
R386	HV755100	R. CAR. FP	100Ω 1/4W		不燃化カーボン抵抗	01
R462	HF353220	R. CAR	2.2Ω 1/2W		カーボン抵抗	
* WE589100	P. C. B.	SUBTRANS	557	J	P C B サブトランス	
* WE589200	P. C. B.	SUBTRANS	557	UC	P C B サブトランス	
* WE589400	P. C. B.	SUBTRANS	557	R	P C B サブトランス	
* WE589500	P. C. B.	SUBTRANS	557, 5850	T	P C B サブトランス	
* WE589600	P. C. B.	SUBTRANS	557, 5850	K	P C B サブトランス	
* WE589700	P. C. B.	SUBTRANS	557	A	P C B サブトランス	
* WE589800	P. C. B.	SUBTRANS	557	B	P C B サブトランス	
* WE589900	P. C. B.	SUBTRANS	557	GE	P C B サブトランス	
* WE590000	P. C. B.	SUBTRANS	557	L	P C B サブトランス	
* WE590100	P. C. B.	SUBTRANS	5850	UC	P C B サブトランス	
* WE590300	P. C. B.	SUBTRANS	5850	A	P C B サブトランス	
* WE590400	P. C. B.	SUBTRANS	457	J	P C B サブトランス	
* WE590500	P. C. B.	SUBTRANS	457, 5840	UC	P C B サブトランス	
* WE590700	P. C. B.	SUBTRANS	457	R	P C B サブトランス	
* WE590800	P. C. B.	SUBTRANS	457, 5840	T	P C B サブトランス	
* WE590900	P. C. B.	SUBTRANS	457, 5840	K	P C B サブトランス	
* WE591000	P. C. B.	SUBTRANS	457, 5840	A	P C B サブトランス	
* WE591100	P. C. B.	SUBTRANS	457, 5840	B	P C B サブトランス	
* WE591200	P. C. B.	SUBTRANS	457, 5840	GE	P C B サブトランス	
* WE591300	P. C. B.	SUBTRANS	457	L	P C B サブトランス	

* New Parts * 新規部品

P.C.B. SUBTRANS

Schm Ref.	PART NO.	Description	Remarks	Markets	部 品 名	Rank
	CB291	V9377800 CN. BS. PIN	3P SE VH SERIES		RL ベース付ポスト	
	CB292	V9377900 CN. BS. PIN	4P SE VH SERIES		RL ベース付ポスト	
△	CB293	WC050700 CLIP. FUSE	EYF52BCY		R ヒューズクリップ	01
△	CB294	WC050700 CLIP. FUSE	EYF52BCY		R ヒューズクリップ	01
	CB401	V7827300 SOCKET	6P TE TUC SERIES		コネクタースOCKET	
△	CB402	VG879900 CN. BS. PIN	2P		ベースピン	01
△	CB403	WC050700 CLIP. FUSE	EYF52BCY		UCGE ヒューズクリップ	01
△	CB404	WC050700 CLIP. FUSE	EYF52BCY		UCGE ヒューズクリップ	01
△	CB405	WC050700 CLIP. FUSE	EYF52BCY		ヒューズクリップ	01
△	CB406	WC050700 CLIP. FUSE	EYF52BCY		ヒューズクリップ	01
△	CB407	VG879900 CN. BS. PIN	2P		ベースピン	01
	CB441	V7826600 CN	16P TE TUC SERIES		コネクタープラグ	01
	CB442	V7828300 SOCKET	16P TE TUC SERIES		コネクタースOCKET	01
	CB445	V7825500 CN	5P TE TUC SERIES	557, 5850	コネクタープラグ	01
	CB446	V7825500 CN	5P TE TUC SERIES	557, 5850	コネクタープラグ	01
	CB451	VM929900 CN. BS. PIN	15P		F P Cコネクター	01
	CB452	VF982300 CN. BS. PIN	17P		F F Cコネクター	01
	CB453	VB858500 CN. BS. PIN	6P		ベースピン	01
	CB454	VQ044500 CN. BS. PIN	11P		UC F F Cコネクター	01
	CB456	VQ045100 CN. BS. PIN	21P		F F Cコネクター	02
	CB457	V7826800 CN	18P TE TUC SERIES		コネクタープラグ	
	CB458	VQ044400 CN. BS. PIN	9P		F F Cコネクター	01
	CB460	V7827000 CN	20P TE TUC SERIES		コネクタープラグ	01
	CB461	V7825800 CN	8P TE TUC SERIES		コネクタープラグ	
	CB462	V7826100 CN	11P TE TUC SERIES		コネクタープラグ	01
	CB463	V7825900 CN	9P TE TUC SERIES	557, 5850	コネクタープラグ	
	CB463	V7825900 CN	9P TE TUC SERIES	457, 5840	UCRTKABGEL コネクタープラグ	
	CB601	V7827800 SOCKET	11P SE TUC SERIES		コネクタースOCKET	
	CB602	V7827200 SOCKET	5P TE TUC SERIES	557, 5850	コネクタースOCKET	
	CB701	V7827600 SOCKET	9P SE TUC SERIES	457, 5840	UCRTKABGEL コネクタースOCKET	
	CB751	V7828300 SOCKET	16P TE TUC SERIES		コネクタースOCKET	01
	CB901	V7827500 SOCKET	8P SE TUC SERIES		コネクタースOCKET	
	C402	UR866220 C. EL	2.2uF 50V		ケミコン	01
	C403	UR866220 C. EL	2.2uF 50V		ケミコン	01
	C404	UA654100 C. MYLAR	0.01uF 50V		マイラーコン	01
	C405	WB687100 C. POL. MTL	0.047uF 400V		JUC メタライズドポリコン	01
	C405	WC041600 C. PP	0.022uF 630V		RTKABGEL P P コン	01
	C406	UR866100 C. EL	1uF 50V		ケミコン	01
	C407	UA653470 C. MYLAR	4700pF 50V		マイラーコン	01
	C408	UA653100 C. MYLAR	1000pF 50V		マイラーコン	03
	C409	WB696300 C. POL. MTL	0.1uF 400V		JUC メタライズドポリコン	
*	C409	WD257600 C. PP	0.047uF 800V		RTKABGEL P P コン	
△	C410	V6185300 C. CE. SAFTY	0.01uF 275V		規格認定コン	
	C411	UR039330 C. EL	3300uF 16V		JUCTKABGEL ケミコン	
*	C411	UR069330 C. EL	3300uF 50V		R ケミコン	
*	C412	WE102900 C. PP	0.01uF 100V		P P コン	
	C451	UR877100 C. EL	10uF 63V		ケミコン	01
	C452	UR837100 C. EL	10uF 16V	557	JRTK ケミコン	01
	C452	UR837100 C. EL	10uF 16V		ケミコン	01

* New Parts * 新規部品

P.C.B. SUBTRANS

Schm Ref.	PART NO.	Description	Remarks	Markets	部 品 名	Rank
C453	UR818220	C. EL 220uF 6.3V			ケミコン	01
C454	WB165500	C. EL 0.33F 5.5V			ゴールドキャパシタ	
C455	UR818220	C. EL 220uF 6.3V			ケミコン	01
C456	UR818100	C. EL 100uF 6.3V			ケミコン	01
C458	UR837330	C. EL 33uF 16V			ケミコン	01
C464	UR866220	C. EL 2.2uF 50V			ケミコン	01
C465	UR866220	C. EL 2.2uF 50V	557	UCABGE	ケミコン	01
C466	UR866220	C. EL 2.2uF 50V			ケミコン	01
C467	UR866220	C. EL 2.2uF 50V			ケミコン	01
C468	UR866220	C. EL 2.2uF 50V			ケミコン	01
C475	UR837470	C. EL 47uF 16V			ケミコン	01
C476	UR837470	C. EL 47uF 16V			ケミコン	01
C477	UR837100	C. EL 10uF 16V			ケミコン	01
C481	UR837470	C. EL 47uF 16V		BGE	ケミコン	01
C482	UR837470	C. EL 47uF 16V		BGE	ケミコン	01
C487	UR837470	C. EL 47uF 16V		BGE	ケミコン	01
C488	UR868100	C. EL 100uF 50V			ケミコン	01
C500	UR837470	C. EL 47uF 16V	5850	UC	ケミコン	01
C603	UR837100	C. EL 10uF 16V			ケミコン	01
C604	UR837100	C. EL 10uF 16V			ケミコン	01
C605	UR837100	C. EL 10uF 16V			ケミコン	01
C608	UR837100	C. EL 10uF 16V			ケミコン	01
C609	UR837100	C. EL 10uF 16V			ケミコン	01
C610	UR837100	C. EL 10uF 16V			ケミコン	01
C612	UR829100	C. EL 1000uF 10V			ケミコン	01
C614	UR829100	C. EL 1000uF 10V			ケミコン	01
C619	UR838470	C. EL 470uF 16V			ケミコン	01
C620	UR838100	C. EL 100uF 16V	557, 5850		ケミコン	01
C621	UR838100	C. EL 100uF 16V	557, 5850		ケミコン	01
C624	UR837470	C. EL 47uF 16V	557, 5850		ケミコン	01
C625	UR837470	C. EL 47uF 16V	557, 5850		ケミコン	01
C626	UA653220	C. MYLAR 2200pF 50V	557, 5850		マイラーコン	01
C628	UR866470	C. EL 4.7uF 50V	557, 5850		ケミコン	01
C629	UR837470	C. EL 47uF 16V	557, 5850		ケミコン	01
C633	UR838100	C. EL 100uF 16V	557, 5850		ケミコン	01
C634	UR838100	C. EL 100uF 16V	557, 5850		ケミコン	01
C635	UR837100	C. EL 10uF 16V	557, 5850		ケミコン	01
C637	UR838100	C. EL 100uF 16V	557, 5850		ケミコン	01
C639	UR837100	C. EL 10uF 16V	557, 5850		ケミコン	01
C648	UR866470	C. EL 4.7uF 50V	557, 5850		ケミコン	01
C652	UR838100	C. EL 100uF 16V	557, 5850		ケミコン	01
C653	UR818330	C. EL 330uF 6.3V	557, 5850		ケミコン	01
C658	UR866470	C. EL 4.7uF 50V	557, 5850		ケミコン	01
C704	UR837100	C. EL 10uF 16V	457, 5840	UCRTKABGEL	ケミコン	01
C705	UR837100	C. EL 10uF 16V	457, 5840	UCRTKABGEL	ケミコン	01
C706	UR837100	C. EL 10uF 16V	457, 5840	UCRTKABGEL	ケミコン	01
C709	UR838100	C. EL 100uF 16V	457, 5840	UCRTKABGEL	ケミコン	01
C710	UR838100	C. EL 100uF 16V	457, 5840	UCRTKABGEL	ケミコン	01
C754	FG651470	C. CE 47pF 50V	557	UCABGE	セラコン	01

* New Parts * 新規部品

P.C.B. SUBTRANS

Schm Ref.	PART NO.	Description	Remarks	Markets	部 品 名	Rank
C755	FG651470	C. CE 47pF 50V	557	UCABGE	セラコン	01
C756	UA654100	C. MYLAR 0.01uF 50V			マイラーコン	01
C757	UA652220	C. MYLAR 220pF 50V			マイラーコン	01
C758	UA652220	C. MYLAR 220pF 50V			マイラーコン	01
C759	UA652220	C. MYLAR 220pF 50V			マイラーコン	01
C760	UA652220	C. MYLAR 220pF 50V			マイラーコン	01
C761	UA652220	C. MYLAR 220pF 50V			マイラーコン	01
C762	UA652220	C. MYLAR 220pF 50V			マイラーコン	01
C763	FG651470	C. CE 47pF 50V			セラコン	01
C764	FG651470	C. CE 47pF 50V			セラコン	01
C765	UR837100	C. EL 10uF 16V			ケミコン	01
C766	UR837100	C. EL 10uF 16V			ケミコン	01
C767	UR837100	C. EL 10uF 16V	557	UCABGE	ケミコン	01
C768	UR837100	C. EL 10uF 16V	557	UCABGE	ケミコン	01
C903	UR837100	C. EL 10uF 16V			ケミコン	01
C904	UR837100	C. EL 10uF 16V			ケミコン	01
C905	UR837100	C. EL 10uF 16V			ケミコン	01
C906	UR829100	C. EL 1000uF 10V			ケミコン	01
C907	UR829100	C. EL 1000uF 10V			ケミコン	01
C909	UR837100	C. EL 10uF 16V	557, 5850		ケミコン	01
C910	UR838470	C. EL 470uF 16V			ケミコン	01
C911	UR837100	C. EL 10uF 16V			ケミコン	01
D401	VT332900	DIODE 1SS355			ダイオード	01
D402	VT332900	DIODE 1SS355			ダイオード	01
D403	VU990500	DIODE. ZENR MA8030-L 2.9V			ツェナーダイオード	
D404	VU993800	DIODE. ZENR MA8068-M 6.8V			ツェナーダイオード	01
D405	VU995400	DIODE. ZENR MA8100-M 10V			ツェナーダイオード	
D406	VT332900	DIODE 1SS355			ダイオード	01
D407	VU995000	DIODE. ZENR MA8091-M 9.1V			ツェナーダイオード	
△ D408	V4756800	DIODE S1NB60 1.0A 600V			D i スタック	01
D409	VT332900	DIODE 1SS355			ダイオード	01
D410	VR253700	DIODE. BRG S1NB20 1A 200V			D i ブリッジ X 4	02
D411	VT332900	DIODE 1SS355			ダイオード	01
D412	VT332900	DIODE 1SS355		R	ダイオード	01
D413	VT332900	DIODE 1SS355		R	ダイオード	01
D451	VT332900	DIODE 1SS355			ダイオード	01
D452	VT332900	DIODE 1SS355			ダイオード	01
D453	VT332900	DIODE 1SS355			ダイオード	01
D454	VT332900	DIODE 1SS355			ダイオード	01
D455	VU992600	DIODE. ZENR MA8051-M 5.1V			ツェナーダイオード	01
D456	VU992600	DIODE. ZENR MA8051-M 5.1V			ツェナーダイオード	01
D457	VU992600	DIODE. ZENR MA8051-M 5.1V			ツェナーダイオード	01
D458	VU992600	DIODE. ZENR MA8051-M 5.1V			ツェナーダイオード	01
D459	VU993000	DIODE. ZENR MA8056-M 5.6V			ツェナーダイオード	01
D461	VU993800	DIODE. ZENR MA8068-M 6.8V	5850	UC	ツェナーダイオード	01
D601	VT332900	DIODE 1SS355	557, 5850		ダイオード	01
D602	VT332900	DIODE 1SS355	557, 5850		ダイオード	01
D603	VT332900	DIODE 1SS355	557, 5850		ダイオード	01
D604	VT332900	DIODE 1SS355	557, 5850		ダイオード	01

* New Parts * 新規部品

P.C.B. SUBTRANS

Schm Ref.	PART NO.	Description	Remarks	Markets	部 品 名	Rank	
D606	VT332900	DIODE	1SS355	557, 5850		ダイオード	01
D607	VT332900	DIODE	1SS355	557, 5850		ダイオード	01
D608	VT332900	DIODE	1SS355	557, 5850		ダイオード	01
D609	VT332900	DIODE	1SS355	557, 5850		ダイオード	01
D610	VT332900	DIODE	1SS355	557, 5850		ダイオード	01
D791	VT332900	DIODE	1SS355	557	UCABGE	ダイオード	01
D792	VT332900	DIODE	1SS355	557	UCABGE	ダイオード	01
D793	VT332900	DIODE	1SS355	557	UCABGE	ダイオード	01
△ F1	VS823300	FUSE	T8A 125V		JUCR	ヒューズ	02
△ F1	KB000790	FUSE	T4A 250V		TKABGEL	ヒューズ	01
△ F2	VS823300	FUSE	T8A 125V		UC	ヒューズ	02
△ F2	VT942900	FUSE	T2.5A 250V		GE	ヒューズ	01
△ F3	KB000790	FUSE	T4A 250V		R	ヒューズ	01
IC401	V8100500	PHOT. CPL	TLP421 GR			フォトカプラ	01
△ IC402	iG001180	IC	TC4013BP FF			ロジックIC	05
IC403	V8100500	PHOT. CPL	TLP421 GR			フォトカプラ	01
IC451	X6618A00	IC. CPU	M30622MWP-229FP	MASK ROM		IC CPU	
IC452	X5041A00	IC	NJU7201L55 5.5V			電源IC SIL	02
IC453	X0082A00	IC	LC72722PM		BGE	IC SOP	
IC601	XH436A00	IC	LA7956			IC	03
IC602	XH436A00	IC	LA7956			IC	03
IC603	XY879A00	IC	TC74HC4053AF(EL)	557, 5850		ロジックIC SOP	03
IC606	XY879A00	IC	TC74HC4053AF(EL)	557, 5850		ロジックIC SOP	03
IC607	XW939A00	IC	TK15420M VIDEO AMP	557, 5850		アンプIC SOP	03
IC608	XW939A00	IC	TK15420M VIDEO AMP	557, 5850		アンプIC SOP	03
IC609	XD598A00	IC	TC74HCU04AFEL INV	557, 5850		ロジックIC	01
IC701	XY879A00	IC	TC74HC4053AF(EL)	457, 5840	UCRTKABGEL	ロジックIC SOP	03
IC702	X2904A00	IC	NJM2581M VIDEO AMP	457, 5840	UCRTKABGEL	アンプIC SOP	06
IC901	XH436A00	IC	LA7956			IC	03
JK451	V9435700	JACK. MNI	MSJ-035-12APC	5850	UC	モノラル ミニジャック	
JK601	VS867300	CN. DIN	4P YKF51-5501			DINコネクタ	03
JK602	V9273500	CN. DIN	2P YKF51-5605			DINコネクタ 2P	
JK603	V9273500	CN. DIN	2P YKF51-5605			DINコネクタ 2P	
JK791	V9435700	JACK. MNI	MSJ-035-12APC	557	UCABGE	モノラル ミニジャック	
JK792	WD195900	JACK	2P	557	UCABGE	ミニ ジャック	
PJ701	V8143900	JACK. PIN	9P SHIELD YKC21	457, 5840	UCRTKABGEL	ピンジャック	04
PJ751	V7046700	JACK. PIN	4P MSP-244V1-01NI			ピンジャック	03
PJ752	V7046700	JACK. PIN	4P MSP-244V1-01NI	557	JRTK	ピンジャック	03
PJ752	V7046800	JACK. PIN	6P MSP-246V1-01NI	557	UCABGE	ピンジャック	
PJ752	V7046700	JACK. PIN	4P MSP-244V1-01NI	5850, 457, 5840		ピンジャック	03
PJ753	V7189700	JACK. PIN	1P			ピンジャック	01
PJ901	V7190000	JACK. PIN	2P			ピンジャック	
PJ902	V7190000	JACK. PIN	2P			ピンジャック	
PJ903	V7189800	JACK. PIN	1P			ピンジャック	01
PN401	V9637500	PIN	L=70 #18			スタイルピン	
PN451	V9637500	PIN	L=70 #18			スタイルピン	
Q401	iC181510	TR	2SC1815 Y			トランジスタ 2SC	01
Q402	VV655700	TR. DGT	DTC144EKA			デジタルトランジスタ	01
Q403	iC181510	TR	2SC1815 Y			トランジスタ 2SC	01

* New Parts * 新規部品

P.C.B. SUBTRANS

Schm Ref.	PART NO.	Description	Remarks	Markets	部 品 名	Rank
△ Q404	WC741200	FET	2SK3850		F E T	
Q451	VP872600	TR	2SA1708 S,T		トランジスタ	01
Q452	VV655700	TR. DGT	DTC144EKA		デジタルトランジスタ	01
Q453	VV556500	TR	2SA1037K Q,R,S		トランジスタ	01
Q454	VV556500	TR	2SA1037K Q,R,S	557	UCABGE	トランジスタ 01
Q455	VV556500	TR	2SA1037K Q,R,S		トランジスタ	01
Q456	VV556500	TR	2SA1037K Q,R,S		トランジスタ	01
Q457	VV556500	TR	2SA1037K Q,R,S		トランジスタ	01
Q458	iC181510	TR	2SC1815 Y		トランジスタ 2 S C	01
Q459	iC174020	TR	2SC1740S QRS		BGE	トランジスタ 01
Q460	VV655700	TR. DGT	DTC144EKA	5850	UC	デジタルトランジスタ 01
Q462	VP872600	TR	2SA1708 S,T	5850	UC	トランジスタ 01
Q464	VV655300	TR. DGT	DTA144EKA	5850	UC	デジタルトランジスタ 01
Q601	iC174020	TR	2SC1740S QRS	557, 5850		トランジスタ 01
Q602	iC174020	TR	2SC1740S QRS			トランジスタ 01
Q603	iC174020	TR	2SC1740S QRS			トランジスタ 01
Q604	iC174020	TR	2SC1740S QRS	557, 5850		トランジスタ 01
Q605	iC174020	TR	2SC1740S QRS			トランジスタ 01
Q606	iC174020	TR	2SC1740S QRS			トランジスタ 01
Q607	iC174020	TR	2SC1740S QRS			トランジスタ 01
Q608	iC174020	TR	2SC1740S QRS			トランジスタ 01
Q610	iC174020	TR	2SC1740S QRS	557, 5850		トランジスタ 01
Q611	iC174020	TR	2SC1740S QRS	557, 5850		トランジスタ 01
Q612	iC174020	TR	2SC1740S QRS	557, 5850		トランジスタ 01
Q613	iC053540	TR	2SC535 A, B, C	557, 5850		トランジスタ 01
Q614	iA101510	TR	2SA1015 Y	557, 5850		トランジスタ 2 S A 01
Q615	iC224030	TR	2SC2240 GR, BL	557, 5850		トランジスタ 01
Q701	VV556400	TR	2SC2412K Q, R, S	457, 5840	UCRTKABGEL	トランジスタ 01
Q751	VZ725900	TR	2SD1938F S, T	557	UCABGE	トランジスタ
Q752	VZ725900	TR	2SD1938F S, T	557	UCABGE	トランジスタ
Q754	VZ725900	TR	2SD1938F S, T	557	UCABGE	トランジスタ
Q755	VZ725900	TR	2SD1938F S, T	557	UCABGE	トランジスタ
Q791	VP872600	TR	2SA1708 S, T	557	UCABGE	トランジスタ 01
Q792	VV655700	TR. DGT	DTC144EKA	557	UCABGE	デジタルトランジスタ 01
Q901	iC174020	TR	2SC1740S QRS			トランジスタ 01
Q902	iC174020	TR	2SC1740S QRS	557, 5850		トランジスタ 01
Q903	iC174020	TR	2SC1740S QRS			トランジスタ 01
Q904	iC174020	TR	2SC1740S QRS			トランジスタ 01
R410	V6730000	R. CAR.	2. 2MΩ 1/2W		UC	放電抵抗 01
R419	HF356220	R. CAR	2. 2KΩ 1/2W			カーボン抵抗
R516	HV753220	R. CAR. FP	2. 2Ω 1/4W			不燃化カーボン抵抗 01
R575	WB784200	R. MTL. OXD	1. 5Ω 1W	5850	UC	金属被膜抵抗
R576	WB784200	R. MTL. OXD	1. 5Ω 1W	5850	UC	金属被膜抵抗
R615	HV755270	R. CAR. FP	270Ω 1/4W	557, 5850		不燃化カーボン抵抗 01
R618	HV755470	R. CAR. FP	470Ω 1/4W			不燃化カーボン抵抗 01
R619	HV755270	R. CAR. FP	270Ω 1/4W			不燃化カーボン抵抗 01
R620	HV755470	R. CAR. FP	470Ω 1/4W	557, 5850		不燃化カーボン抵抗 01
R629	HV753470	R. CAR. FP	4. 7Ω 1/4W			不燃化カーボン抵抗 01
R661	HV755470	R. CAR. FP	470Ω 1/4W	557, 5850		不燃化カーボン抵抗 01

* New Parts * 新規部品

P.C.B. SUBTRANS & P.C.B. CONVERSION

Schm Ref.	PART NO.	Description	Remarks	Markets	部 品 名	Rank
R663	HV755470	R. CAR. FP 470Ω 1/4W	557, 5850		不燃化カーボン抵抗	01
R667	HV753470	R. CAR. FP 4.7Ω 1/4W	557, 5850		不燃化カーボン抵抗	01
R672	HV755470	R. CAR. FP 470Ω 1/4W	557, 5850		不燃化カーボン抵抗	01
R675	HV754220	R. CAR. FP 22Ω 1/4W	557, 5850		不燃化カーボン抵抗	01
R676	HV755470	R. CAR. FP 470Ω 1/4W	557, 5850		不燃化カーボン抵抗	01
R686	HV755220	R. CAR. FP 220Ω 1/4W	557, 5850		不燃化カーボン抵抗	01
R687	HV755220	R. CAR. FP 220Ω 1/4W	557, 5850		不燃化カーボン抵抗	01
R716	HV753100	R. CAR. FP 1Ω 1/4W	457, 5840	UCRTKABGEL	不燃化カーボン抵抗	01
R717	HV753100	R. CAR. FP 1Ω 1/4W	457, 5840	UCRTKABGEL	不燃化カーボン抵抗	01
R908	HV755270	R. CAR. FP 270Ω 1/4W			不燃化カーボン抵抗	01
R910	HV755270	R. CAR. FP 270Ω 1/4W	557, 5850		不燃化カーボン抵抗	01
R916	HV754100	R. CAR. FP 10Ω 1/4W			不燃化カーボン抵抗	01
△ RY401	WE513800	RELAY DC HRM3H-DC12V			リレー 12V	
ST401	V4040500	SCR. TERM M3			スクリュー/ターミナル	01
ST402	V4040500	SCR. TERM M3			スクリュー/ターミナル	01
ST451	V4040500	SCR. TERM M3			スクリュー/ターミナル	01
△ SW291	WB493700	VOLT. SELCT R8140246		R	電圧切替器	
△ SW291	WD073700	VOLT. SELCT R8140254		L	電圧切替器	
△ T401	XW605A00	TRANS. PWR		J	電源トランス	04
△ T401	XW606A00	TRANS. PWR		UC	電源トランス	
* △ T401	X6351A00	TRANS. PWR		R	電源トランス	
△ T401	XW608A00	TRANS. PWR		TKABGEL	電源トランス	
△ TE401	VU543100	OUTLET. AC 2P		JUC	A C アウトレット	03
△ TE401	V5867400	OUTLET. AC 2P AC-182-GB-11V		RTK	A C アウトレット 2P	
△ TE401	VT915000	OUTLET. AC 1P		A	A C アウトレット	06
△ TE401	VU543300	OUTLET. AC 1P		B	A C アウトレット	05
△ TE401	VU543400	OUTLET. AC 2P		GEL	A C アウトレット	05
XL451	WA674700	RSNR. CE 16MHz CSTLS16M0X51			セラミック振動子	
XL452	V3930900	RSNR. CRY5 4.332MHz		BGE	水晶振動子	05
* * *	WE594400	P. C. B. CONVERSION	557	J	P C B コンバージョン	
* * *	WE594500	P. C. B. CONVERSION	557, 5850	UCK	P C B コンバージョン	
* * *	WE594600	P. C. B. CONVERSION	557, 5850	RTABGEL	P C B コンバージョン	
CB701	WE262500	CN 14P SE	557	J	D 端子コネクタ	
CB702	WE262500	CN 14P SE	557	J	D 端子コネクタ	
CB703	WD398400	CN. DIN 14P YKF45-3011	557	J	D I N コネクタ	05
CB704	V7827600	SOCKET 9P SE TUC SERIES	557, 5850		コネクタソケット	
CB705	V7827200	SOCKET 5P TE TUC SERIES	557, 5850		コネクタソケット	
CB706	VB858600	CN. BS. PIN 7P	557, 5850		ベースピン	01
C716	UR837470	C. EL 47uF 16V	557, 5850		ケミコン	01
C717	UR837470	C. EL 47uF 16V	557, 5850		ケミコン	01
C718	UR837470	C. EL 47uF 16V	557, 5850		ケミコン	01
C719	UR866100	C. EL 1uF 50V	557, 5850		ケミコン	01
C720	UR838100	C. EL 100uF 16V	557, 5850		ケミコン	01
C725	UR867100	C. EL 10uF 50V	557, 5850		ケミコン	01
C726	UR838100	C. EL 100uF 16V	557, 5850		ケミコン	01
C728	UR866100	C. EL 1uF 50V	557, 5850		ケミコン	01

* New Parts * 新規部品

P.C.B. CONVERSION

Schm Ref.	PART NO.	Description	Remarks	Markets	部 品 名	Rank
C729	UR837470	C. EL 47uF 16V	557, 5850		ケミコン	01
C734	UR838100	C. EL 100uF 16V	557, 5850		ケミコン	01
C735	UR838100	C. EL 100uF 16V	557, 5850		ケミコン	01
C740	UR865470	C. EL 0. 47uF 50V	557, 5850		ケミコン	01
C747	UR837470	C. EL 47uF 16V	557, 5850	RTABGEL	ケミコン	01
C748	UR837100	C. EL 10uF 16V	557, 5850		ケミコン	01
C749	UR838100	C. EL 100uF 16V	557, 5850		ケミコン	01
C759	UR837470	C. EL 47uF 16V	557, 5850		ケミコン	01
C760	UR837470	C. EL 47uF 16V	557, 5850		ケミコン	01
C761	UR837470	C. EL 47uF 16V	557, 5850		ケミコン	01
C764	UR837100	C. EL 10uF 16V	557, 5850		ケミコン	01
C767	UR837470	C. EL 47uF 16V	557, 5850		ケミコン	01
C768	UR838100	C. EL 100uF 16V	557, 5850		ケミコン	01
C774	UR837470	C. EL 47uF 16V	557, 5850	RTABGEL	ケミコン	01
C777	UR837470	C. EL 47uF 16V	557, 5850		ケミコン	01
C780	UR837470	C. EL 47uF 16V	557, 5850		ケミコン	01
C783	UR865470	C. EL 0. 47uF 50V	557, 5850	RTABGEL	ケミコン	01
C785	UR837470	C. EL 47uF 16V	557, 5850		ケミコン	01
C787	UR865470	C. EL 0. 47uF 50V	557, 5850	RTABGEL	ケミコン	01
C792	UR837100	C. EL 10uF 16V	557, 5850	RTABGEL	ケミコン	01
C794	UR866100	C. EL 1uF 50V	557, 5850	RTABGEL	ケミコン	01
C795	UR866220	C. EL 2. 2uF 50V	557, 5850		ケミコン	01
C796	UR866100	C. EL 1uF 50V	557, 5850	RTABGEL	ケミコン	01
C797	UR865470	C. EL 0. 47uF 50V	557, 5850	RTABGEL	ケミコン	01
C798	UR837470	C. EL 47uF 16V	557, 5850	RTABGEL	ケミコン	01
C801	UR866100	C. EL 1uF 50V	557, 5850	RTABGEL	ケミコン	01
C804	UR865470	C. EL 0. 47uF 50V	557, 5850	RTABGEL	ケミコン	01
C806	UR866220	C. EL 2. 2uF 50V	557, 5850		ケミコン	01
C813	UR838100	C. EL 100uF 16V	557, 5850		ケミコン	01
C815	UR838100	C. EL 100uF 16V	557, 5850		ケミコン	01
C816	UR866100	C. EL 1uF 50V	557, 5850		ケミコン	01
C817	UR837100	C. EL 10uF 16V	557, 5850		ケミコン	01
C818	UR837100	C. EL 10uF 16V	557, 5850		ケミコン	01
C822	UR837100	C. EL 10uF 16V	557, 5850		ケミコン	01
C823	UR837100	C. EL 10uF 16V	557, 5850		ケミコン	01
C824	UR837100	C. EL 10uF 16V	557, 5850		ケミコン	01
C825	UR837100	C. EL 10uF 16V	557, 5850		ケミコン	01
D702	VT332900	DIODE 1SS355	557, 5850		ダイオード	01
D703	VT332900	DIODE 1SS355	557, 5850		ダイオード	01
D705	VT332900	DIODE 1SS355	557, 5850		ダイオード	01
D706	VT332900	DIODE 1SS355	557, 5850		ダイオード	01
D707	VT332900	DIODE 1SS355	557	J	ダイオード	01
D708	VT332900	DIODE 1SS355	557	J	ダイオード	01
D709	VT332900	DIODE 1SS355	557	J	ダイオード	01
D710	VT332900	DIODE 1SS355	557	J	ダイオード	01
D711	VT332900	DIODE 1SS355	557	J	ダイオード	01
D712	VT332900	DIODE 1SS355	557	J	ダイオード	01
IC701	XS790A00	IC TC74HC4052AF MPX	557, 5850		ロジック IC	02
IC702	XS790A00	IC TC74HC4052AF MPX	557, 5850		ロジック IC	02

* New Parts * 新規部品

P.C.B. CONVERSION & P.C.B. VIDEO

Schm Ref.	PART NO.	Description	Remarks	Markets	部 品 名	Rank
IC703	X2904A00	IC	NJM2581M VIDEO AMP	557, 5850		アンプIC SOP 06
IC704	XS790A00	IC	TC74HC4052AF MPX	557	J	ロジックIC 02
IC705	X4349A00	IC	TC90A49F	557, 5850		IC デジタル 09
IC706	XZ509A00	IC	TC74VHCU04FT INVER	557, 5850		ロジックIC 01
IC707	XZ509A00	IC	TC74VHCU04FT INVER	557, 5850		ロジックIC 01
IC708	XY879A00	IC	TC74HC4053AF(EL)	557, 5850		ロジックIC SOP 03
IC709	XW939A00	IC	TK15420M VIDEO AMP	557, 5850		アンプIC SOP 03
* IC710	X4346A00	IC	TA8772AN	557, 5850	RTABGEL	IC アナログ
IC711	X4347A00	IC	TA1270BF	557, 5850		IC アナログ 10
IC712	XJ609A00	IC	NJM7809FA 9V	557, 5850		電源IC SIL 02
* IC713	X6520A00	IC	BA50BC0T	557, 5850		電源IC
IC714	XE436A00	IC	NJM79M05FA	557, 5850		IC 03
PJ701	V8143900	JACK PIN	9P SHIELD YKC21	557, 5850		ピンジャック 04
Q702	VV556500	TR	2SA1037K Q,R,S	557, 5850		トランジスタ 01
Q703	VV556400	TR	2SC2412K Q,R,S	557, 5850		トランジスタ 01
Q704	VV556400	TR	2SC2412K Q,R,S	557, 5850		トランジスタ 01
Q705	VV556400	TR	2SC2412K Q,R,S	557, 5850		トランジスタ 01
Q706	VV556400	TR	2SC2412K Q,R,S	557, 5850		トランジスタ 01
Q707	VV556400	TR	2SC2412K Q,R,S	557, 5850		トランジスタ 01
Q708	VV556400	TR	2SC2412K Q,R,S	557, 5850		トランジスタ 01
Q709	VV556400	TR	2SC2412K Q,R,S	557, 5850		トランジスタ 01
Q710	VV556500	TR	2SA1037K Q,R,S	557, 5850		トランジスタ 01
Q711	VV556500	TR	2SA1037K Q,R,S	557, 5850		トランジスタ 01
Q712	VV556500	TR	2SA1037K Q,R,S	557, 5850		トランジスタ 01
Q713	VV556400	TR	2SC2412K Q,R,S	557, 5850	RTABGEL	トランジスタ 01
Q714	VV556400	TR	2SC2412K Q,R,S	557, 5850	RTABGEL	トランジスタ 01
R733	HV753100	R. CAR. FP	1Ω 1/4W	557, 5850		不燃化カーボン抵抗 01
R749	HV753100	R. CAR. FP	1Ω 1/4W	557, 5850	RTABGEL	不燃化カーボン抵抗 01
R750	HV753100	R. CAR. FP	1Ω 1/4W	557, 5850		不燃化カーボン抵抗 01
R805	HV753220	R. CAR. FP	2.2Ω 1/4W	557, 5850		不燃化カーボン抵抗 01
R806	HV753220	R. CAR. FP	2.2Ω 1/4W	557, 5850		不燃化カーボン抵抗 01
R812	HV753100	R. CAR. FP	1Ω 1/4W	557, 5850		不燃化カーボン抵抗 01
R813	WB784200	R. MTL. OXD	1.5Ω 1W	557, 5850		金属被膜抵抗
R814	WB784200	R. MTL. OXD	1.5Ω 1W	557, 5850		金属被膜抵抗
R815	WB784200	R. MTL. OXD	1.5Ω 1W	557, 5850		金属被膜抵抗
R816	VP939700	R. MTL. FLM	4.7Ω 1W	557, 5850		金属被膜抵抗 01
XL701	WB749900	RSNR. CRYST	3.579545MHz	557, 5850		水晶振動子
XL702	V5345200	RSNR. CE	CSBLA503KECZF30-B0	557, 5850		セラミック振動子 01
* XL703	WB750000	RSNR. CRYST	4.433619MHz	557, 5850	RTABGEL	水晶振動子
* WE774200	SCR. BND. HD	3x10 MFZN2W3	557, 5850			バインドBタイトネジ
	WA709000	P. C. B.	VIDEO	457	J	P C B ビデオ 10
CB851	VB858300	CN. BS. PIN	4P	457	J	コネクタベースポスト 01
CB852	V7684100	CN	14P SE YKF SERIES	457	J	D端子コネクタ
CB853	V7684100	CN	14P SE YKF SERIES	457	J	D端子コネクタ
CB854	V7684100	CN	14P SE YKF SERIES	457	J	D端子コネクタ
C865	UR828100	C. EL	100uF 10V	457	J	ケミコン 01

* New Parts * 新規部品

P.C.B. VIDEO & P.C.B. XM

Schm Ref.	PART NO.	Description	Remarks	Markets	部 品 名	Rank	
C866	UR828100	C. EL	100uF 10V	457	J	ケミコン	01
D851	VT332900	DIODE	1SS355	457	J	ダイオード	01
D852	VT332900	DIODE	1SS355	457	J	ダイオード	01
D853	VT332900	DIODE	1SS355	457	J	ダイオード	01
D854	VT332900	DIODE	1SS355	457	J	ダイオード	01
D855	VT332900	DIODE	1SS355	457	J	ダイオード	01
D856	VT332900	DIODE	1SS355	457	J	ダイオード	01
D857	VT332900	DIODE	1SS355	457	J	ダイオード	01
IC851	XY879A00	IC	TC74HC4053AF(EL)	457	J	ロジックIC SOP	03
IC852	XY879A00	IC	TC74HC4053AF(EL)	457	J	ロジックIC SOP	03
IC853	X2904A00	IC	NJM2581M VIDEO AMP	457	J	アンプIC SOP	06
Q851	VV556400	TR	2SC2412K Q,R,S	457	J	トランジスタ	01
R872	HV753100	R. CAR. FP	1Ω 1/4W	457	J	不燃化カーボン抵抗	01
R873	HV753100	R. CAR. FP	1Ω 1/4W	457	J	不燃化カーボン抵抗	01
*	WE625300	P. C. B.	XM	557	UC	P C B X M	
*	WE625400	P. C. B.	XM	5850, 457, 5840	UC	P C B X M	
CB21	LB919030	CN. BS. PIN	3P		UC	ベース付ポスト	01
CB23	VB858400	CN. BS. PIN	5P	557	UC	ベースピン	01
CB24	VM859500	CN. BS. PIN	11P		UC	F F C コネクタ	01
* CN1	WE161800	CN	CAM-C16 4P SE		UC	シリアルバスコネクタ	
C22	UR73A100	C. EL	10000uF 16V		UC	ケミコン	03
C24	UR73A100	C. EL	10000uF 16V		UC	ケミコン	03
C26	UR866100	C. EL	1uF 50V		UC	ケミコン	01
C28	UR837470	C. EL	47uF 16V		UC	ケミコン	01
C33	VE326000	C. MYLAR. ML	0.1uF 50V		UC	積層マイラーコン	01
C35	UR837100	C. EL	10uF 16V	557	UC	ケミコン	01
C36	UR837470	C. EL	47uF 16V	557	UC	ケミコン	01
C38	UR837470	C. EL	47uF 16V	557	UC	ケミコン	01
C39	UR837470	C. EL	47uF 16V	557	UC	ケミコン	01
C40	UR837100	C. EL	10uF 16V	557	UC	ケミコン	01
C41	UR837100	C. EL	10uF 16V	557	UC	ケミコン	01
C42	US063330	C. EL	3300pF 50V	557	UC	ケミコン	01
C43	US063330	C. EL	3300pF 50V	557	UC	ケミコン	01
C46	UR837470	C. EL	47uF 16V	557	UC	ケミコン	01
C47	UR837470	C. EL	47uF 16V	557	UC	ケミコン	01
C50	UR837470	C. EL	47uF 16V		UC	ケミコン	01
* D1	WE674800	DIODE	AVRL161A1R1NTB		UC	チップバリスタ	
* D2	WE674800	DIODE	AVRL161A1R1NTB		UC	チップバリスタ	
* D3	WE674800	DIODE	AVRL161A1R1NTB		UC	チップバリスタ	
△ D21	WA653100	DIODE. BRG	KBP103G 1.0A 200V		UC	ダイオードブリッジ	02
D26	V2376600	DIODE. SHOT	RB500V-40		UC	ショットキーダイオード	01
G21	WB438000	TERM. GND	M4 SD00433-21		UC	アース端子	
G22	WB438000	TERM. GND	M4 SD00433-21		UC	アース端子	
* IC1	X6227A00	IC. CPU	XMDT TRANSCIEVER		UC	C P U / 周辺 I C	
IC21	X6051A00	IC	UPC29M33T-E1-AZ		UC	電源 I C	
△ IC22	XJ607A00	IC	NJM7805FA 5V		UC	I C	02

* New Parts * 新規部品

P.C.B. XM

Schm Ref.	PART NO.	Description	Remarks	Markets	部 品 名	Rank
IC23	X2080A00	IC SN74AHCT1G32DCKR		UC	ロジックIC	01
IC24	X3693A00	IC SN74LV245APWR TRAN		UC	ロジックICTSSOP	
* IC25	X6231A00	IC AK4384ET	557	UC	IC	
IC26	X5482A00	IC NE5532DR OP AMP	557	UC	アンプIC SOP	
△ IC27	XU814A00	IC PQ05RD11 +5V 1.0A		UC	電源IC	03
PN1	V9637500	PIN L=70 #18		UC	スタイルピン	
R38	HV753100	R. CAR. FP 1Ω 1/4W	557	UC	不燃化カーボン抵抗	01
R53	HV753100	R. CAR. FP 1Ω 1/4W	557	UC	不燃化カーボン抵抗	01
R54	HV753100	R. CAR. FP 1Ω 1/4W	557	UC	不燃化カーボン抵抗	01
* XL1	WE436500	RSNR. CRYST 45.1584M DSX840GA		UC	水晶振動子	

* New Parts * 新規部品

Chip Parts

Schm Ref.	PART NO.	Description	Remarks	Markets	部 品 名	Rank
	US035100	C. CE. M. CHP	0. 1uF		チツアセラコン	01
	US044220	C. CE. M. CHP	0. 022uF		チツアセラコン	01
	US060500	C. CE. CHP	5pF		チツアセラコン	01
	US060800	C. CE. CHP	8pF		チツアセラコン	01
	US061100	C. CE. M. CHP	10pF		チツアセラコン	01
	US061120	C. CE. CHP	12pF		チツアセラ (C H)	01
	US061150	C. CE. CHP	15pF		チツアセラコン	01
	US061180	C. CE. CHP	18pF		チツアセラコン	01
	US061220	C. CE. M. CHP	22pF		チツアセラコン	01
	US061270	C. CE. M. CHP	27pF		チツアセラコン	01
	US061330	C. CE. M. CHP	33pF		チツアセラコン	01
	US061470	C. CE. M. CHP	47pF		チツアセラコン	01
	US062100	C. CE. M. CHP	100pF		チツアセラコン	01
	US062120	C. CE. CHP	120pF		チツアセラコン	01
	US062180	C. CE. CHP	180pF		チツアセラコン	01
	US062220	C. CE. CHP	220pF		チツアセラコン	01
	US062330	C. CE. M. CHP	330pF		チツアセラコン	01
	US062560	C. CE. CHP	560pF		チツアセラ (S L)	01
	US063100	C. CE. M. CHP	1000pF		チツアセラコン	01
	US063120	C. CE. M. CHP	1200pF		チツアセラコン	01
	US063220	C. CE. M. CHP	2200pF		チツアセラコン	01
	US064100	C. CE. M. CHP	0. 01uF		チツアセラコン	01
	US065100	C. CE. M. CHP	0. 1uF		チツアセラ F	01
	US1 26100	C. CE. CHP	1uF		チツアセラ F	01
	US1 35100	C. CE. CHP	0. 1uF		チツアセラ F	01
	US1 35220	C. CE. CHP	0. 22uF		チツアセラ F	01
	US1 35330	C. CE. CHP	0. 33uF		チツアセラ (F)	01
	US1 45100	C. CE. CHP	0. 1uF		チツアセラ (F)	01
	RD350000	R. CHP	0Ω		チツア抵抗	01
	RD353220	R. CHP	2. 2Ω		チツア抵抗	01
	RD354100	R. CHP	10Ω		チツア抵抗	01
	RD354220	R. CHP	22Ω		チツア抵抗	01
	RD354270	R. CHP	27Ω		チツア抵抗	01
	RD354470	R. CHP	47Ω		チツア抵抗	01
	RD354750	R. CHP	75Ω		チツア抵抗	01
	RD354820	R. CHP	82Ω		チツア抵抗	01
	RD355100	R. CHP	100Ω		チツア抵抗	01
	RD355220	R. CHP	220Ω		チツア抵抗	01
	RD355270	R. CHP	270Ω		チツア抵抗	01
	RD355330	R. CHP	330Ω		チツア抵抗	01
	RD355360	R. CHP	360Ω		チツア抵抗	01
	RD355470	R. CHP	470Ω		チツア抵抗	01
	RD355510	R. CHP	510Ω		チツア抵抗	01
	RD355680	R. CHP	680Ω		チツア抵抗	01
	RD355820	R. CHP	820Ω		チツア抵抗	01
	RD356100	R. CHP	1KΩ		チツア抵抗	01
	RD356120	R. CHP	1. 2KΩ		チツア抵抗	01
	RD356150	R. CHP	1. 5KΩ		チツア抵抗	01
	RD356220	R. CHP	2. 2KΩ		チツア抵抗	01
	RD356270	R. CHP	2. 7KΩ		チツア抵抗	01
	RD356300	R. CHP	3KΩ		チツア抵抗	01
	RD356330	R. CHP	3. 3KΩ		チツア抵抗	01
	RD356390	R. CHP	3. 9KΩ		チツア抵抗	01

* New Parts * 新規部品

Chip Parts

Schm Ref.	PART NO.	Description	Remarks	Markets	部 品 名	Rank
	RD356470	R. CHP	4. 7KΩ		チツア抵抗	01
	RD356560	R. CHP	5. 6KΩ		チツア抵抗	01
	RD356680	R. CHP	6. 8KΩ		チツア抵抗	01
	RD357100	R. CHP	10KΩ		チツア抵抗	01
	RD357110	R. CHP	11KΩ		チツア抵抗	01
	RD357130	R. CHP	13KΩ		チツア抵抗	01
	RD357150	R. CHP	15KΩ		チツア抵抗	01
	RD357180	R. CHP	18KΩ		チツア抵抗	01
	RD357220	R. CHP	22KΩ		チツア抵抗	01
	RD357270	R. CHP	27KΩ		チツア抵抗	01
	RD357300	R. CHP	30KΩ		チツア抵抗	01
	RD357330	R. CHP	33KΩ		チツア抵抗	01
	RD357470	R. CHP	47KΩ		チツア抵抗	01
	RD357680	R. CHP	68KΩ		チツア抵抗	01
	RD358100	R. CHP	100KΩ		チツア抵抗	01
	RD358150	R. CHP	150KΩ		チツア抵抗	01
	RD358220	R. CHP	220KΩ		チツア抵抗	01
	RD358270	R. CHP	270KΩ		チツア抵抗	01
	RD358470	R. CHP	470KΩ		チツア抵抗	01
	RD358680	R. CHP	680KΩ		チツア抵抗	01
	RD359100	R. CHP	1MΩ		チツア抵抗	01
	RF354820	R. CAR, CHP	82Ω		チツア抵抗	01
	RF355820	R. CHP	820Ω		チツア抵抗	01
	RF356220	R. CHP	2. 2KΩ		チツア抵抗	01
	RF356330	R. CHP	3. 3KΩ		チツア抵抗	01
	RF356470	R. CHP	4. 7KΩ		チツア抵抗	01
	RF356560	R. CHP	5. 6KΩ		チツア抵抗	01
	RF356680	R. CHP	6. 8KΩ		チツア抵抗	01
	RF357200	R. CHP	20KΩ		チツア抵抗	01
	RF357470	R. CHP	47KΩ		チツア抵抗	01

* New Parts * 新規部品

EXPLODED VIEW RX-V557/DSP-AX557

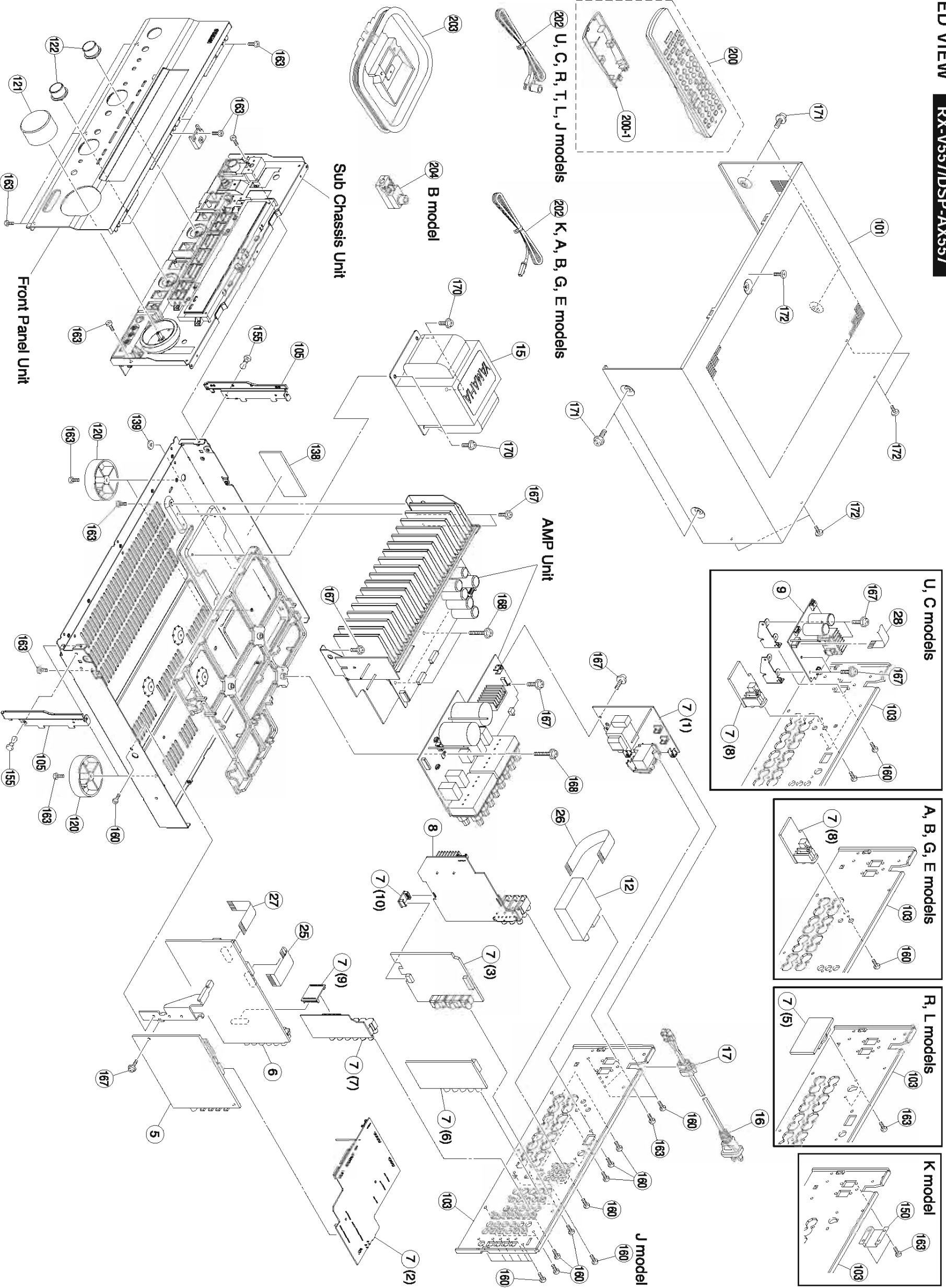

MECHANICAL PARTS RX-V557/DSP-AX557

Schm Ref.	PART NO.	Description	Remarks	Markets	部 品 名	Rank
*	5	WE592900	P.C.B. ASS'Y	JRTKABGEL	P C B D S P	
*	5	WE593000	P.C.B. ASS'Y	UC	P C B D S P	
*	6	WE593600	P.C.B. ASS'Y	JRTKL	P C B D S P	
*	6	WE593700	P.C.B. ASS'Y	UC	P C B D S P	
*	6	WE593800	P.C.B. ASS'Y	ABGE	フジックシヨウ	
*	7	WE589100	P.C.B. ASS'Y	J	フジックシヨウ	
*	7	WE589200	P.C.B. ASS'Y	UC	P C B	
*	7	WE589400	P.C.B. ASS'Y	R	サフトランス	
*	7	WE589500	P.C.B. ASS'Y	T	サフトランス	
*	7	WE589600	P.C.B. ASS'Y	K	サフトランス	
*	7	WE589700	P.C.B. ASS'Y	A	サフトランス	
*	7	WE589800	P.C.B. ASS'Y	B	サフトランス	
*	7	WE589900	P.C.B. ASS'Y	GE	サフトランス	
*	7	WE590000	P.C.B. ASS'Y	L	サフトランス	
*	7	WE594400	P.C.B. ASS'Y	J	コンバーシヨウ	
*	8	WE594500	P.C.B. ASS'Y	UCK	P C B	
*	8	WE594600	P.C.B. ASS'Y	RTABGEL	P C B	
*	9	WE625300	P.C.B. ASS'Y	UC	コンバーシヨウ	
*	12	V6782200	AM/FM TUNER	J	AM/FM チューナ	13
*	12	V6782300	AM/FM TUNER	UCRTL	AM/FM チューナ	
*	12	V6782400	AM/FM TUNER	KABGE	AM/FM チューナ	
*	15	X5250800	POWER TRANSFORMER	J	電源トランス	
*	15	X6337A00	POWER TRANSFORMER	UC	電源トランス	
*	15	X6339A00	POWER TRANSFORMER	RL	電源トランス	
*	15	X6340A00	POWER TRANSFORMER	TK	電源トランス	
*	15	X6341A00	POWER TRANSFORMER	A	電源トランス	
*	15	X5251B00	POWER TRANSFORMER	BGE	電源トランス	
*	16	V4007600	POWER CABLE	J	電源コード	05
*	16	V9293500	POWER CABLE	UC	電源コード	
*	16	WC3922700	POWER CABLE	R	電源コード	
*	16	VZ542500	POWER CABLE	T	電源コード	05
*	16	WC753000	POWER CABLE	K	電源コード	
*	16	WC743700	POWER CABLE	A	電源コード	
*	16	VV437300	POWER CABLE	B	電源コード	08
*	16	V9293600	POWER CABLE	GEL	電源コード	
*	17	V2438700	CORD STOPPER		コードストッパー	02
*	25	ME118070	FLEXIBLE FLAT CABLE		カード電線 C&C	02
*	26	ME115140	FLEXIBLE FLAT CABLE		カード電線 C&C	03
*	27	ME113070	FLEXIBLE FLAT CABLE		カード電線 C&C	01
*	28	ME111300	FLEXIBLE FLAT CABLE	UC	カード電線 C&C	02
*	101	WE184600	TOP COVER		トップカバー	
*	101	WE184500	TOP COVER	BL	トップカバー	
*	101	WE184700	TOP COVER	TI	トップカバー	
*	103	WE230900	REAR PANEL	J	リヤパネル	
*	103	WE172200	REAR PANEL	UC	リヤパネル	
*	103	WE172400	REAR PANEL	R	リヤパネル	
*	103	WE172500	REAR PANEL	T	リヤパネル	
*	103	WE172600	REAR PANEL	K	リヤパネル	
*	103	WE172700	REAR PANEL	A	リヤパネル	
*	103	WE172900	REAR PANEL	B	リヤパネル	
*	103	WE173000	REAR PANEL	GE	リヤパネル	
*	103	WE172800	REAR PANEL	L	リヤパネル	
*	105	WE183100	PLATE SIDE		プレートサイド	
*	105	WE183000	PLATE SIDE	GD	プレートサイド	

* New Parts * 新規部品

Schm Ref.	PART NO.	Description	Remarks	Markets	部 品 名	Rank
*	105	WE183200	PLATE SIDE	TI	プレートサイド	
*	120	V0042500	LEG	GD	レッグ	03
*	120	V0025000	LEG	BL, TI	レッグ	02
*	121	WC494500	KNOB D48	GD	ノブ D 48	02
*	121	WC494400	KNOB D48	BL	ノブ D 48	
*	121	WC494600	KNOB D48	TI	ノブ D 48	
*	122	WC494900	KNOB D20	GD	ノブ D 21.5	01
*	122	WC494800	KNOB D20	BL	ノブ D 21.5	
*	122	WC495000	KNOB D20	TI	ノブ D 21.5	
*	138	V3198100	DAMPER		ダンパー	
*	139	WC879000	DAMPER		ダンパー	01
*	150	V8466300	COVER/AC OUTLETS		カバー/A/Cプラグレット	
*	155	V0368600	PUSH RIVET	K	プラグレット	01
*	160	WE774100	BIND HEAD BOUNDING B-T. SCREW		ボンドヘッドBタイトネジ	
*	163	WE774300	BIND HEAD B-TIGHT SCREW		ボンドヘッドBタイトネジ	
*	167	VT669300	PW HEAD B-TIGHT SCREW		PWヘッドBタイトネジ	01
*	168	WE774600	SCREW IC		スクルーIC	
*	170	WE774700	BIND HEAD S-TIGHT SCREW		バインドヘッドSタイトネジ	
*	171	V0069600	PW HEAD S-TIGHT SCREW	GD, TI	PWヘッドSタイトネジ	01
*	171	VH313200	BW HEAD S-TIGHT SCREW	BL	BWヘッドSタイトネジ	01
*	172	WE200400	DISH HEAD B-TIGHT SCREW	GD, TI	DISH Bタイトネジ	
*	172	WE200500	DISH HEAD B-TIGHT SCREW	BL	DISH Bタイトネジ	01
*	200	WE458700	ACCESSORIES		付属品	
*	200	WE458800	REMOTE CONTROL	BW091J	リモコン	
*	200	AAK34140	BATTERY COVER	BW091K	リモコン電池蓋	05
*	200-1	V6267000	INDOOR FM ANTENNA	71-0910-02000	FM簡易アンテナ	03
*	202	V0147100	INDOOR FM ANTENNA		FM簡易アンテナ	02
*	203	VR248500	AM LOOP ANTENNA		AMループアンテナ	03
*	204	VE364900	ANTENNA ADAPTER BATTERY, MANGANESE DRY		整合器	
*	204	VE364900	ANTENNA ADAPTER BATTERY, MANGANESE DRY		マンガン電池 4 P C S	03

* New Parts * 新規部品

EXPLODED VIEW (FRONT PANEL UNIT & SUB CHASSIS UNIT) **RX-V557/DSP-AX557**

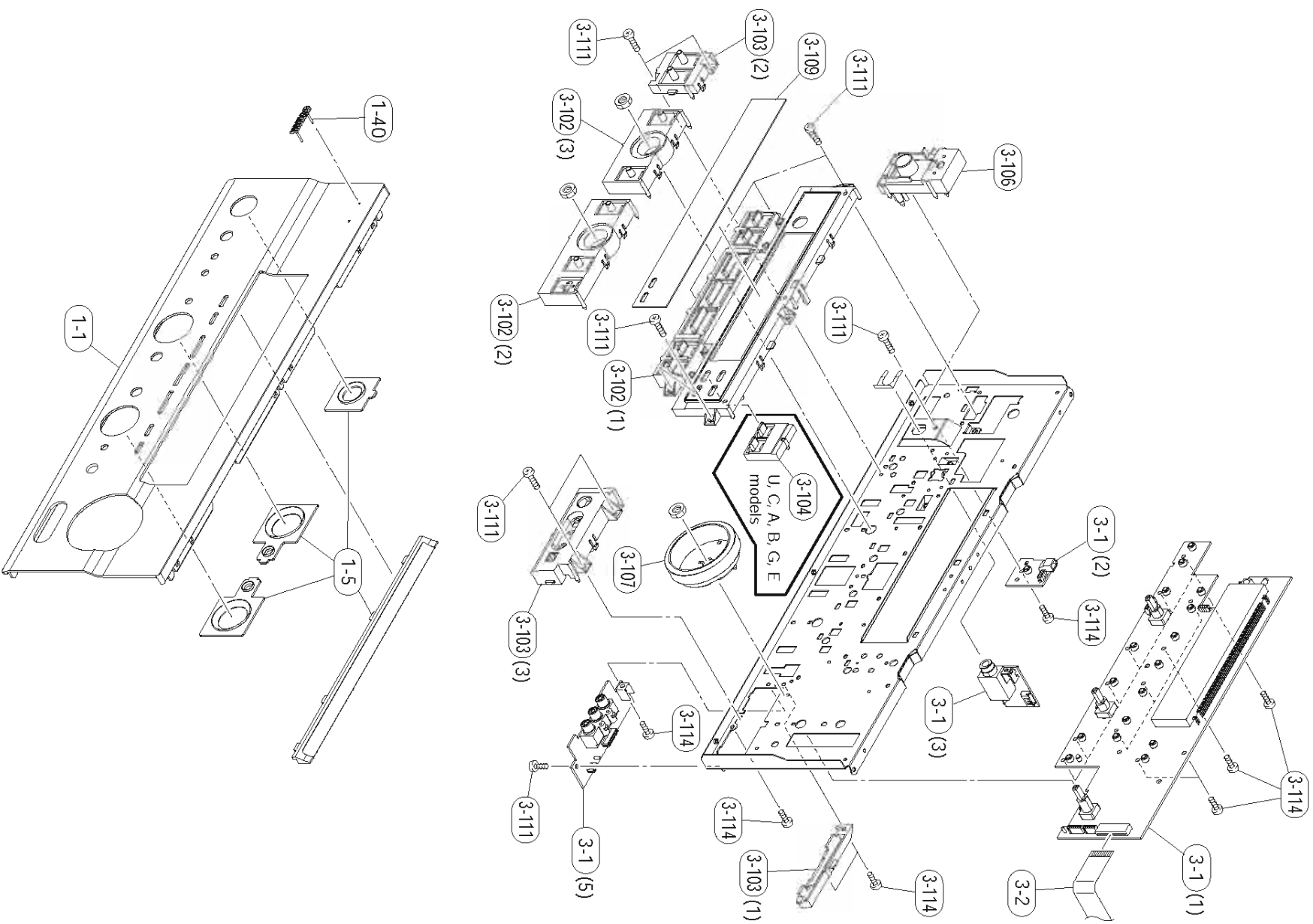

MECHANICAL PARTS (FRONT PANEL UNIT & SUB CHASSIS UNIT) **RX-V557/DSP-AX557**

Ref.	Schm	PART NO.	Description	Remarks	Markets	部 品 名	Rank
1-1	*	WE256000	FRONT PANEL	60	J	フロントパネル	
1-1	*	WE178100	FRONT PANEL	60	RTK	フロントパネル	
1-1	*	WE177200	FRONT PANEL	BL	UC	フロントパネル	
1-1	*	WE177300	FRONT PANEL	BL	RABGE	フロントパネル	
1-1	*	WE255900	FRONT PANEL	TI		フロントパネル	
1-5	*	WE155900	ESCUTCHEON/657	60		エスカッション 657	
1-5	*	WE155800	ESCUTCHEON/657	BL		エスカッション 657	
1-5	*	WE156000	ESCUTCHEON/657	TI		エスカッション 657	
1-40	*	V6034200	EMBLEM	60		エンブレム	
1-40	*	V6034100	EMBLEM	BL, TI		エンブレム	
3-1	*	WE594000	P. C. B. ASS'Y			PCB オペレーション	
3-2	*	WE121350	FLEXIBLE FLAT CABLE			カード電線 C&C	
3-102	*	WC490900	BUTTONCASE 650	60		ボタンケース 650	
3-102	*	WC490800	BUTTONCASE 650	BL		ボタンケース 650	
3-102	*	WC491000	BUTTONCASE 650	TI		ボタンケース 650	
3-103	*	WE185700	BUTTON 650	60		ボタン 650	
3-103	*	WE185600	BUTTON 650	BL		ボタン 650	
3-103	*	WE185800	BUTTON 650	TI		ボタン 650	
3-104	*	WE182400	BUTTON/ZONE2		UCABGE	ボタン/ZONE2	
3-106	*	WE156200	BUTTON/STANDBY	60		ボタンSTANDBY	
3-106	*	WE156100	BUTTON/STANDBY	BL		ボタンSTANDBY	
3-106	*	WE156300	BUTTON/STANDBY	TI		ボタンSTANDBY	
3-107	*	WC493200	ESCUTCHEON/VOL	60		エスカッションVOL	
3-107	*	WC493100	ESCUTCHEON/VOL	BL		エスカッションVOL	
3-107	*	WC493300	ESCUTCHEON/VOL	TI		エスカッションVOL	
3-109	*	WC495200	SHEET, WINDOW		JRTKL	シート/ウインドウ	
3-109	*	WE183700	SHEET, WINDOW		UCABGE	シート/ウインドウ	
3-111	*	WE74300	BLIND HEAD B-TIGHT SCREW	3x8		バインドヘッドタイトネジ	
3-111	*	WE74800	BLIND HEAD P-TIGHT SCREW	3x8		バインドヘッドタイトネジ	
3-114	*						

* New Parts * 新部品

1 ■ EXPLODED VIEW (AMP UNIT) **RX-V557/DSP-AX557**

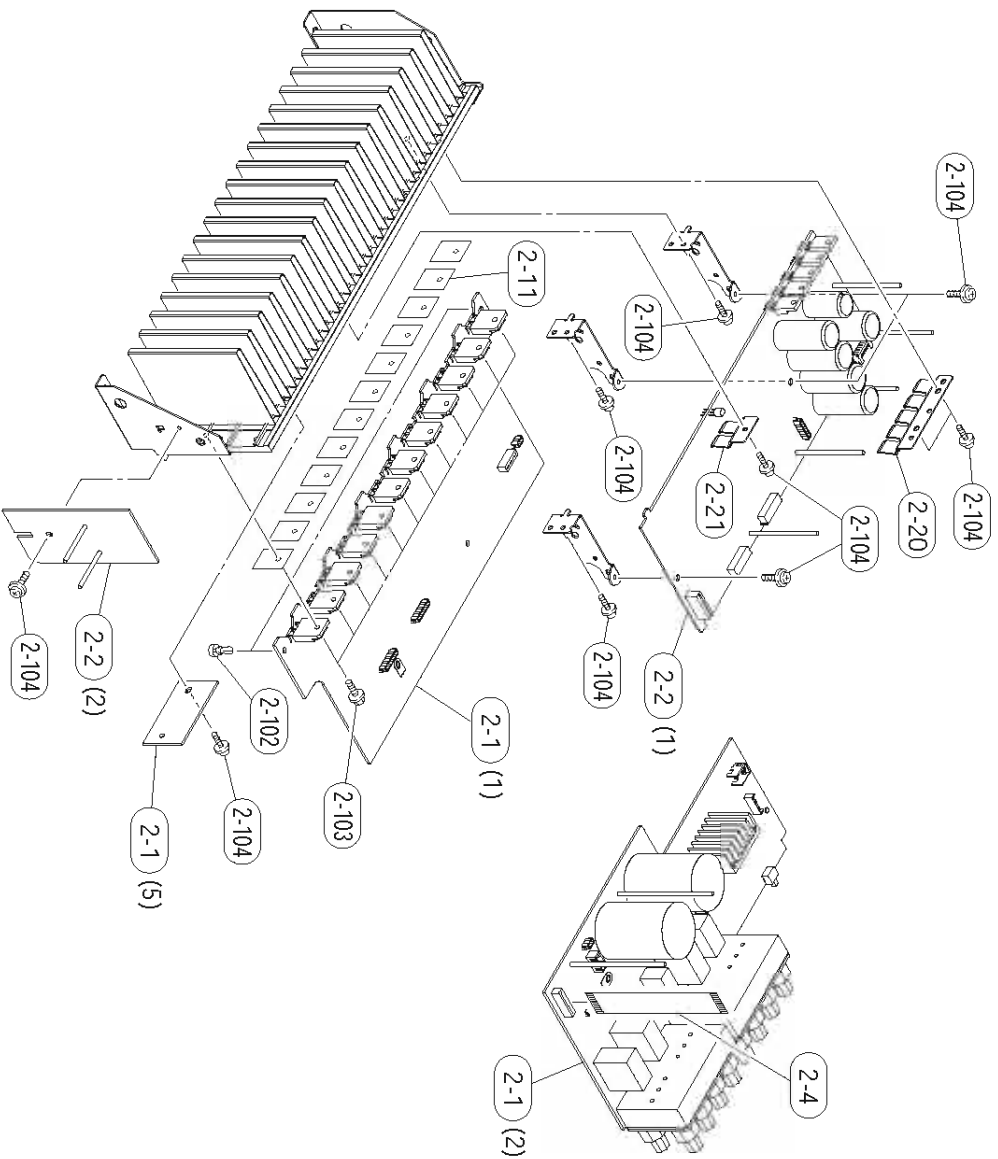

■ MECHANICAL PARTS (AMP UNIT) **RX-V557/DSP-AX557**

Schm Ref.	PART NO.	Description	Remarks	Markets	部 品 名	Rank
2-1	ME588000	P.C.B. ASS'Y		JUCRTA	P C B メイン	
2-1	ME588100	P.C.B. ASS'Y		K8SEL	P C B メイン	
2-2	ME588700	P.C.B. ASS'Y			P C B パワー	
2-4	MF117140	FLEXIBLE FLAT CABLE			カード電線 C & C	01
2-11	VH849300	RADIATION SHEET		JUCRTAK	シート/放熱	01
2-20	WC656000	SUPPORT/TR 5P			サポート/TR 5P	01
2-21	V2673000	SUPPORT/TR 2P			サポート/TR 2P	01
2-102	V0368600	PUSH RIVET			プッシュリベット	01
2-103	VK173200	SCREW, TRANSISTOR			スクルー-TR	01
2-104	VT669300					

* New Parts * 新部品

MECHANICAL PARTS HTR-5850 RX-V457/HTR-5840/DSP-AX457

Schm Ref.	PART NO.	Description	Remarks	Markets	部 品 名	Rank
*	5	WES93000	P.C.B. ASS'Y	UC	P.C.B D S P	
*	5	WES92900	P.C.B. ASS'Y	TKA	P.C.B D S P	
*	5	WES93100	P.C.B. ASS'Y	J	P.C.B D S P	
*	5	WES93200	P.C.B. ASS'Y	UC	P.C.B D S P	
*	5	WES93300	P.C.B. ASS'Y	RTKABGEL	P.C.B D S P	
*	6	WES93600	P.C.B. ASS'Y	UC	P.C.B フォンクシヨウ	
*	7	WES90100	P.C.B. ASS'Y	UC	P.C.B サフトランス	
*	7	WES89500	P.C.B. ASS'Y	T	P.C.B サフトランス	
*	7	WES89600	P.C.B. ASS'Y	K	P.C.B サフトランス	
*	7	WES90300	P.C.B. ASS'Y	A	P.C.B サフトランス	
*	7	WES90400	P.C.B. ASS'Y	J	P.C.B サフトランス	
*	7	WES90500	P.C.B. ASS'Y	UC	P.C.B サフトランス	
*	7	WES90700	P.C.B. ASS'Y	R	P.C.B サフトランス	
*	7	WES90800	P.C.B. ASS'Y	T	P.C.B サフトランス	
*	7	WES90900	P.C.B. ASS'Y	K	P.C.B サフトランス	
*	7	WES91000	P.C.B. ASS'Y	A	P.C.B サフトランス	
*	7	WES91100	P.C.B. ASS'Y	B	P.C.B サフトランス	
*	7	WES91200	P.C.B. ASS'Y	GE	P.C.B サフトランス	
*	7	WES91300	P.C.B. ASS'Y	L	P.C.B サフトランス	
*	8	WES94500	P.C.B. ASS'Y	UCK	P.C.B コンバーシヨウ	
*	8	WES94600	P.C.B. ASS'Y	TA	P.C.B コンバーシヨウ	
*	8	WA709000	P.C.B. ASS'Y	J	P.C.B ヒデオ	
*	9	WE825400	P.C.B. ASS'Y	UC	P.C.B XM	
	12	V6782200	AM/FM TUNER	J	AM/FM チューナ	
	12	V6782300	AM/FM TUNER	UCRTL	AM/FM チューナ	
	12	V6782400	AM/FM TUNER	KABGE	AM/FM チューナ	
	15	X5250B00	POWER TRANSFORMER	J	電源トランス	
	15	X6337A00	POWER TRANSFORMER	UC	電源トランス	
	15	X6339A00	POWER TRANSFORMER	RL	電源トランス	
	15	X6340A00	POWER TRANSFORMER	TK	電源トランス	
	15	X6341A00	POWER TRANSFORMER	A	電源トランス	
	15	X5251B00	POWER TRANSFORMER	BGE	電源トランス	
	16	V4007600	POWER CABLE	J	電源コード	
	16	V9293500	POWER CABLE	UC	電源コード	
	16	WC992700	POWER CABLE	R	電源コード	
	16	V2542500	POWER CABLE	T	電源コード	
	16	WC753000	POWER CABLE	K	電源コード	
	16	WC743700	POWER CABLE	A	電源コード	
	16	V4437300	POWER CABLE	B	電源コード	
	16	V9293600	POWER CABLE	GE	電源コード	
	16	VNS63700	POWER CABLE	L	電源コード	
	17	V2438700	CORD STOPPER		コードストップパ-	
	25	MF118070	FLEXIBLE FLAT CABLE		カード電線 C&C	
	26	MF115140	FLEXIBLE FLAT CABLE		カード電線 C&C	
	26	MF115070	FLEXIBLE FLAT CABLE		カード電線 C&C	
	27	MF113070	FLEXIBLE FLAT CABLE		カード電線 C&C	
	28	MF111300	FLEXIBLE FLAT CABLE	UC	カード電線 C&C	
*	101	WE184900	TOP COVER	GD	トップカバー	
*	101	WE184800	TOP COVER	BL	トップカバー	
*	101	WE185000	TOP COVER	TI, SI	トップカバー	
*	103	WE174800	REAR PANEL	UC	リヤパネル	
*	103	WE175000	REAR PANEL	T	リヤパネル	
*	103	WE175100	REAR PANEL	K	リヤパネル	
*	103	WE175200	REAR PANEL	A	リヤパネル	

* New Parts * 新規部品

Schm Ref.	PART NO.	Description	Remarks	Markets	部 品 名	Rank
*	103	WE174700	REAR PANEL	AX457	J	リヤパネル
*	103	WE173800	REAR PANEL	V457	UC	リヤパネル
*	103	WE174000	REAR PANEL	V457	R	リヤパネル
*	103	WE174100	REAR PANEL	V457	T	リヤパネル
*	103	WE174200	REAR PANEL	V457	K	リヤパネル
*	103	WE174300	REAR PANEL	V457	A	リヤパネル
*	103	WE174500	REAR PANEL	V457	B	リヤパネル
*	103	WE174600	REAR PANEL	V457	GE	リヤパネル
*	103	WE174400	REAR PANEL	V457	L	リヤパネル
*	103	WE175500	REAR PANEL	5840	UC	リヤパネル
*	103	WE175700	REAR PANEL	5840	T	リヤパネル
*	103	WE175800	REAR PANEL	5840	K	リヤパネル
*	103	WE175900	REAR PANEL	5840	A	リヤパネル
*	103	WE176000	REAR PANEL	5840	B	リヤパネル
*	103	WE176100	REAR PANEL	5840	GE	リヤパネル
*	120	V00442500	LEG	GD	レッグ	
*	120	VV544300	LEG	5850BL, 5840BL	レッグ (B K)	
*	120	V5025000	LEG	V457BL, TI, SI	レッグ	
*	121	WE183400	KNOB/D48	GD	ノブ/D48	
*	121	WE183300	KNOB/D48	BL	ノブ/D48	
*	121	WE183600	KNOB/D48	TI	ノブ/D48	
*	121	WE183600	KNOB/D48	SI	ノブ/D48	
*	122	WC560600	KNOB D23	GD	ノブ D23	
	122	WC560500	KNOB D23	BL	ノブ D23	
	122	WC560700	KNOB D23	TI	ノブ D23	
	122	WC560800	KNOB D23	SI	ノブ D23	
	138	V3198100	DAMPER		ダンパー	
	139	WC879000	DAMPER		ダンパー	
	150	V8466300	COVER/AC OUTLETS		カバー/A/Cプラケット	
	151	WE952600	BARRIER/PCB		バリヤ/P.C.B	
	155	V0368600	PUSH RIVET	P3555-B	プッシュリベット	
	160	WE774100	BIND HEAD BONDING B-1, SCREW	3x8	ボンディングBタイトネジ	
	163	WE774300	BIND HEAD B-TIGHT SCREW	3x8	バインドBタイトネジ	
	167	VT669300	PN HEAD B-TIGHT SCREW	3x8-8	PWヘッドBタイトネジ	
	168	WE774600	SCREW IC	3x18	スクルーイーC	
	170	WE774700	BIND HEAD S-TIGHT SCREW	4x10	バインドSタイトネジ	
	171	V0069600	PN HEAD S-TIGHT SCREW	4x8-10	PWヘッドSタイトネジ	
	171	VH313200	BW HEAD S-TIGHT SCREW	4x8-10	BWヘッドSタイトネジ	
	172	WE200400	DISH HEAD B-TIGHT SCREW	3x6	DISH Bタイトネジ	
	172	WE200500	DISH HEAD B-TIGHT SCREW	3x6	DISH Bタイトネジ	
	200	WE458700	ACCESSORIES		付属品	
	200-1	AAV34140	REMOTE CONTROL	RAY254(BW091J)	リモコン	
	201	WE458900	REMOTE CONTROL	71-0910-02000	電池蓋	
	201-1	AAV46580	BATTERY COVER	RAY304	リモコン	
	202	V6267000	INDOOR FM ANTENNA	103RRC-244-01G	電池蓋	
	202	V0147100	INDOOR FM ANTENNA	1.4m 1pc	F M簡易アンテナ	
	203	VR248500	AM LOOP ANTENNA	1.0m 1pc	F M簡易アンテナ	
	204	VE364900	ANTENNA ADAPTER	PAL	AMループアンテナ	
			BATTERY, MANGANESE DRY	UM-4NE, 4pcs	整合器	
			BATTERY	SUM-3N, 2pcs	2 P C S	

* New Parts * 新規部品

EXPLODED VIEW (FRONT PANEL UNIT) HTR-5850

RX-V457/HTR-5840/DSP-AX457

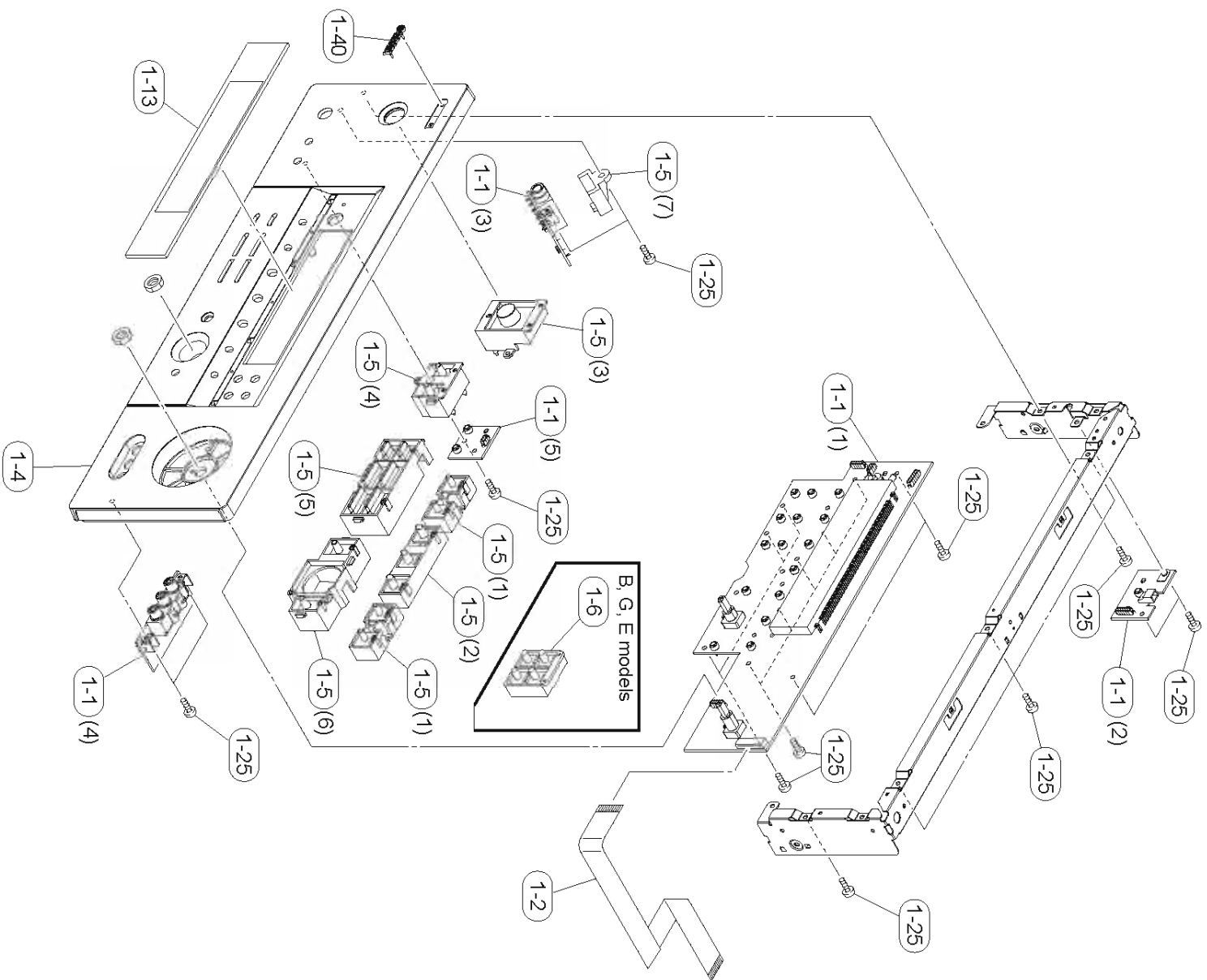

MECHANICAL PARTS (FRONT PANEL UNIT) HTR-5850

RX-V457/HTR-5840/DSP-AX457

Ref.	Schm	PART NO.	Description	Remarks	Markets	部 品 名	Rank
1-1	*	WE594100	P.C.B. ASS'Y			P.C.B	
1-2	*	ME121350	FLEXIBLE FLAT CABLE	OPERATION 21P 350mm P=1.25		ケーブル・フロッピー	
1-4	*	WE287700	FRONT PANEL ASS'Y		UC	フロントパネルASS'Y	
1-4	*	WE180700	FRONT PANEL ASS'Y		UC	フロントパネルASS'Y	
1-4	*	WE287800	FRONT PANEL ASS'Y		UC	フロントパネルASS'Y	
1-4	*	WE287900	FRONT PANEL ASS'Y		KA	フロントパネルASS'Y	
1-4	*	WE187400	FRONT PANEL ASS'Y		J	フロントパネルASS'Y	
1-4	*	WE187100	FRONT PANEL ASS'Y		RTKL	フロントパネルASS'Y	
1-4	*	WE186400	FRONT PANEL ASS'Y		UC	フロントパネルASS'Y	
1-4	*	WE186500	FRONT PANEL ASS'Y		PABGE	フロントパネルASS'Y	
1-4	*	WE283700	FRONT PANEL ASS'Y		C	フロントパネルASS'Y	
1-4	*	WE283800	FRONT PANEL ASS'Y		ABGE	フロントパネルASS'Y	
1-4	*	WE188000	FRONT PANEL ASS'Y		J	フロントパネルASS'Y	
1-4	*	WE187600	FRONT PANEL ASS'Y		RKL	フロントパネルASS'Y	
1-4	*	WE191100	FRONT PANEL ASS'Y		UC	フロントパネルASS'Y	
1-4	*	WE190500	FRONT PANEL ASS'Y		UC	フロントパネルASS'Y	
1-4	*	WE190600	FRONT PANEL ASS'Y		CE	フロントパネルASS'Y	
1-4	*	WE191500	FRONT PANEL ASS'Y		UC	フロントパネルASS'Y	
1-4	*	WE191600	FRONT PANEL ASS'Y		KA	フロントパネルASS'Y	
1-4	*	WE191700	FRONT PANEL ASS'Y		BGE	フロントパネルASS'Y	
1-5	*	WC492000	BUTTONCASE 450		GD	ボタンのケース450	
1-5	*	WC492200	BUTTONCASE 450		5850BL,5840BL	ボタンのケース450	
1-5	*	WC491900	BUTTONCASE 450		V457BL	ボタンのケース450	
1-5	*	WC492100	BUTTONCASE 450		TI	ボタンのケース450	
1-5	*	WC492300	BUTTONCASE 450		SI	ボタンのケース450	
1-6	*	WC492700	BUTTON/RDS 450		BGE	ボタンのRDS450	
1-13	*	WE815500	SHEET, WINDOW		GD, TI	シート/ウインドウ	
1-13	*	WE815400	SHEET, WINDOW		BL	シート/ウインドウ	
1-25	*	WE774800	BLIND HEAD P-TIGHT SCREW	3x8	SI	ブラインドPタイトネジ	
1-40	*	V6034200	EMBLEM		GD	エンブレム	
1-40	*	V6034100	EMBLEM		BL, TI, SI	エンブレム	

* New Parts * 新部品

1 ■ EXPLODED VIEW (AMP UNIT) HTR-5850 RX-V457/HTR-5840/DSP-AX457

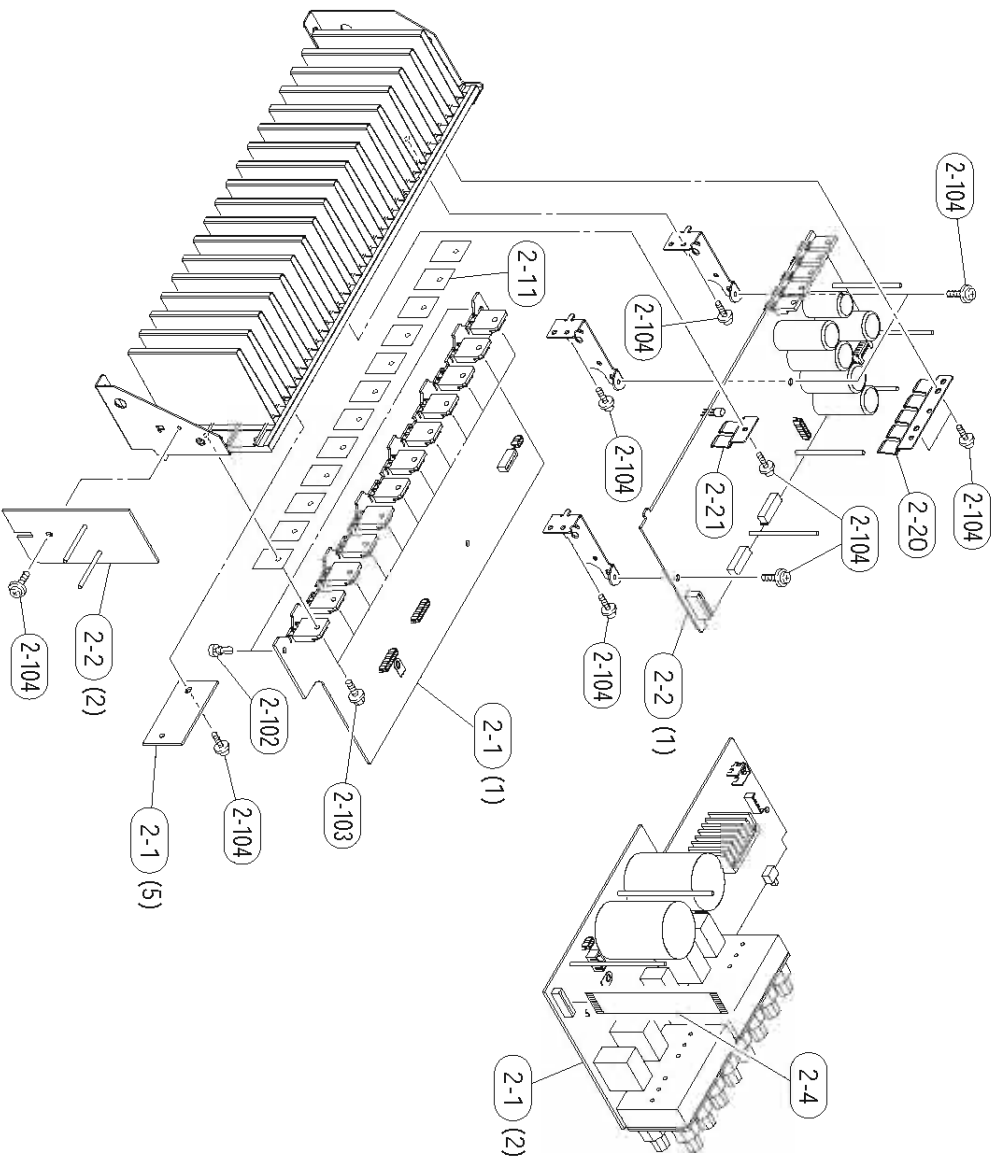

■ MECHANICAL PARTS (AMP UNIT) HTR-5850 RX-V457/HTR-5840/DSP-AX457

Schm Ref.	PART NO.	Description	Remarks	Markets	部 品 名	Rank
2-1	ME588000	P.C.B. ASS'Y	5850	UCTA	P C B ヌｲﾝ	
2-1	ME588100	P.C.B. ASS'Y	5850	K	P C B ヌｲﾝ	
2-1	ME588200	P.C.B. ASS'Y	V457, 5840, AX457	JUCRTA	P C B ヌｲﾝ	
2-1	ME588300	P.C.B. ASS'Y	V457, 5840	K9SEL	P C B ヌｲﾝ	
2-2	ME588700	P.C.B. ASS'Y	5850		P C B ヌｲﾝ	
2-2	ME588800	P.C.B. ASS'Y	V457, 5840		P C B ヌｲﾝ	
2-4	MF117140	FLEXIBLE FLAT CABLE			カｰﾄﾞ電線 C & C	
2-11	VW849300	RADIATION SHEET	17P 140mm P=1.25		シｰﾄ/放熱	
2-20	WC656000	SUPPORT/TR 5P	19x24		サポｰﾄ/TR 5 P	
2-21	VZ673000	SUPPORT/TR 2P			サポｰﾄ/TR 2 P	
2-102	VQ368600	PUSH RIVET			ﾌｯｼﾞｪﾘｯﾍﾞｯﾄ	
2-103	VK173200	SCREW, TRANSISTOR			ｽｸﾘｰﾆｰTR	
2-104	VT669300	PM HEAD B-TIGHT SCREW	3x8-8		PWﾊﾞｯﾄBﾀｲﾄﾈｼﾞ	

* New Parts * 新部品

■ REMOTE CONTROL RAV254: RX-V557 (U, C, R, T, K, A, L models), HTR-5850, DSP-AX557, RX-V457 (U, C, R, T, K, A, L models), HTR-5840 (U, C, T, K, A models), DSP-AX457
 RAV255: RX-V557 (B, G, E models)

● SCHEMATIC DIAGRAM

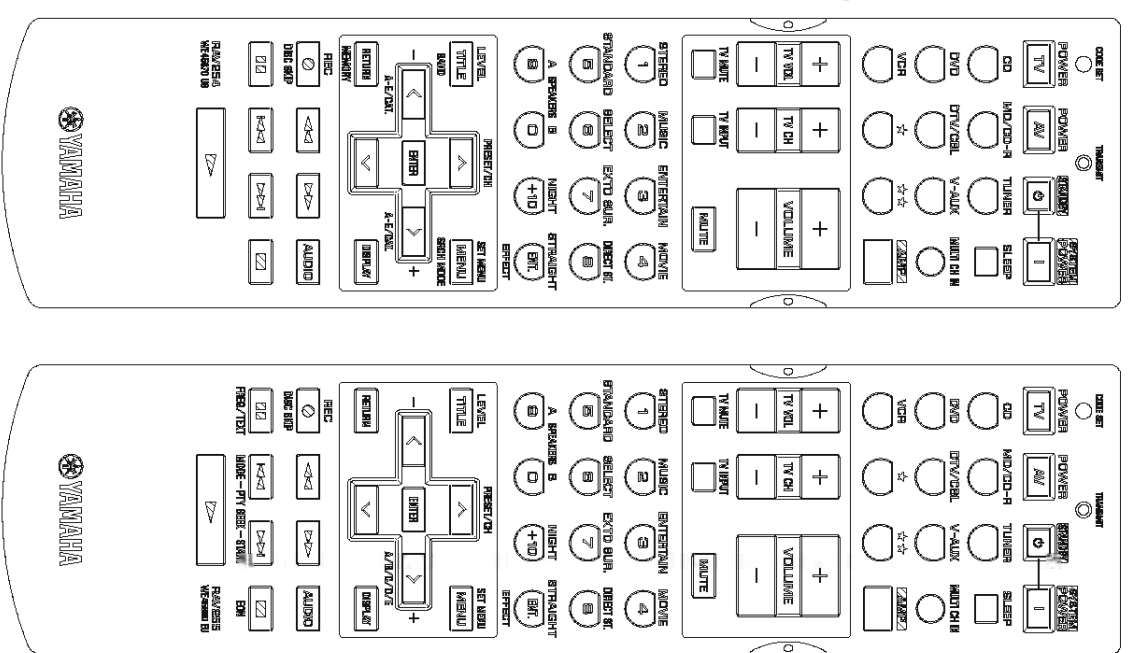
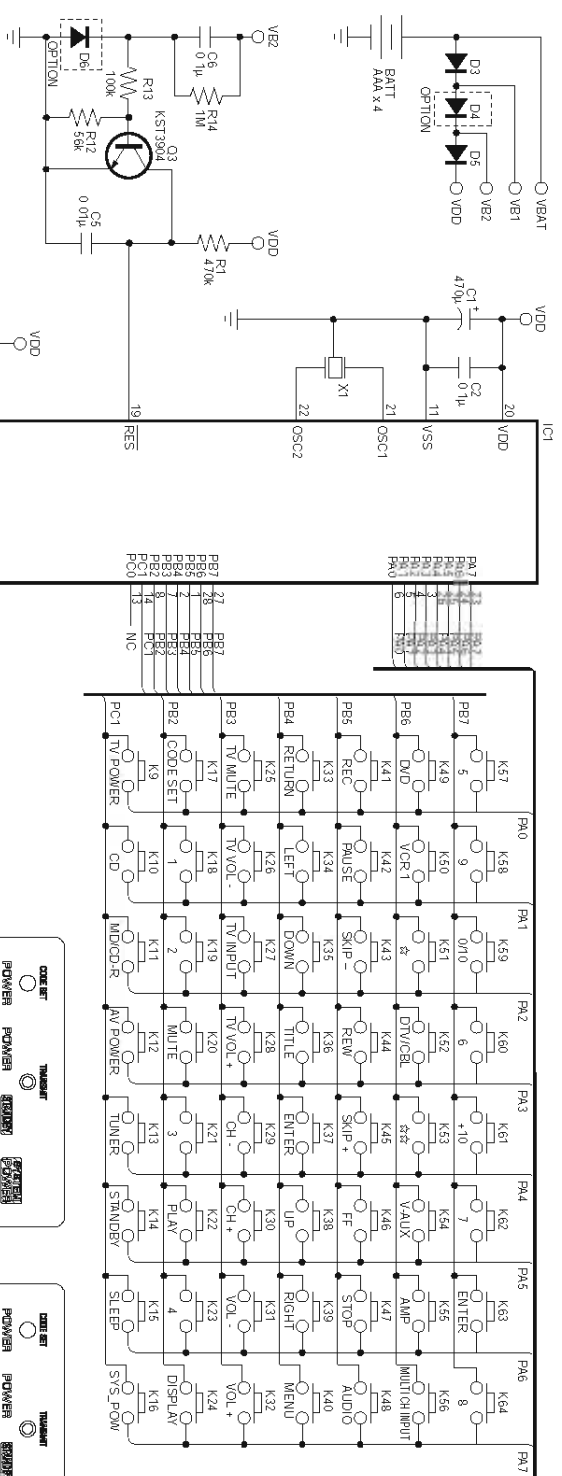

Key Schematic No	Key No	Function	YPC	MAIN	ZONE2	SYSTEM	Yamaha1	Yamaha2	LD	Yamaha1	Yamaha2	Yamaha3	Yamaha4	Yamaha5	MD	Yamaha1	Yamaha2	Yamaha3	TUNER	AMP FIX	
1	K17	CODE SET	-	-	-	-	-	-	-	-	-	-	-	-	-	-	-	-	-	-	-
2	K9	TV POWER	-	-	-	-	-	-	-	-	-	-	-	-	-	-	-	-	-	-	-
3	K12	AV POWER	-	-	-	-	-	-	-	-	-	-	-	-	-	-	-	-	-	-	-
4	K14	STANDBY	7A-1E	7E-7F	7E-8B	7A-1E	-	-	-	-	-	-	-	-	-	-	-	-	-	-	-
5	K16	SYSTEM POWER	7A-1D	7E-7E	7E-8A	7A-1D	-	-	-	-	-	-	-	-	-	-	-	-	-	-	-
6	K10	CD	7A-15	7A-16	7A-D1	-	-	-	-	-	-	-	-	-	-	-	-	-	-	-	-
7	K11	M/D/C/D-R	7A-C9	7A-C9	7A-CF	-	-	-	-	-	-	-	-	-	-	-	-	-	-	-	-
8	K13	TUNER	7A-16	7A-16	7A-D2	-	-	-	-	-	-	-	-	-	-	-	-	-	-	-	-
9	K15	SLEEP	7A-C1	7A-C1	7A-CD	-	-	-	-	-	-	-	-	-	-	-	-	-	-	-	-
10	K49	DVD	7A-57	7A-57	-	-	-	-	-	-	-	-	-	-	-	-	-	-	-	-	-
11	K52	DTV/CBL	7A-54	7A-54	7A-D9	-	-	-	-	-	-	-	-	-	-	-	-	-	-	-	-
12	K54	V-ALX	7A-55	7A-55	7A-D8	-	-	-	-	-	-	-	-	-	-	-	-	-	-	-	-
13	K56	MULTI CH INPUT	7A-87	7A-87	7A-D6	-	-	-	-	-	-	-	-	-	-	-	-	-	-	-	-
14	K50	VCR	7A-0F	7A-0F	7A-D6	-	-	-	-	-	-	-	-	-	-	-	-	-	-	-	-
15	K51	★ ★	7A-13	7A-13	7A-D7	-	-	-	-	-	-	-	-	-	-	-	-	-	-	-	-
16	K53	★ ★	-	-	-	-	-	-	-	-	-	-	-	-	-	-	-	-	-	-	-
17	K55	AMP	-	-	-	-	-	-	-	-	-	-	-	-	-	-	-	-	-	-	-
18	K28	TV VOL +	-	-	-	-	-	-	-	-	-	-	-	-	-	-	-	-	-	-	-
19	K30	TV CH +	-	-	-	-	-	-	-	-	-	-	-	-	-	-	-	-	-	-	-
20	K32	TV VOL -	7A-1A	7A-1A	-	-	-	-	-	-	-	-	-	-	-	-	-	-	-	-	-
21	K26	TV VOL +	-	-	-	-	-	-	-	-	-	-	-	-	-	-	-	-	-	-	-
22	K29	TV CH -	-	-	-	-	-	-	-	-	-	-	-	-	-	-	-	-	-	-	-
23	K31	VOLUME -	7A-1B	7A-1B	-	-	-	-	-	-	-	-	-	-	-	-	-	-	-	-	-
24	K25	TV MUTE	-	-	-	-	-	-	-	-	-	-	-	-	-	-	-	-	-	-	-
25	K27	TV INPUT	-	-	-	-	-	-	-	-	-	-	-	-	-	-	-	-	-	-	-
26	K20	MUTE	7A-1C	7A-1C	7A-D3	-	-	-	-	-	-	-	-	-	-	-	-	-	-	-	-
27	K18	1	-	-	-	-	-	-	-	-	-	-	-	-	-	-	-	-	-	-	-
28	K19	2	-	-	-	-	-	-	-	-	-	-	-	-	-	-	-	-	-	-	-
29	K21	3	-	-	-	-	-	-	-	-	-	-	-	-	-	-	-	-	-	-	-
30	K23	4	-	-	-	-	-	-	-	-	-	-	-	-	-	-	-	-	-	-	-
31	K57	5	-	-	-	-	-	-	-	-	-	-	-	-	-	-	-	-	-	-	-
32	K60	6	-	-	-	-	-	-	-	-	-	-	-	-	-	-	-	-	-	-	-
33	K62	7	-	-	-	-	-	-	-	-	-	-	-	-	-	-	-	-	-	-	-
34	K64	8	-	-	-	-	-	-	-	-	-	-	-	-	-	-	-	-	-	-	-
35	K58	9	-	-	-	-	-	-	-	-	-	-	-	-	-	-	-	-	-	-	-
36	K59	0	-	-	-	-	-	-	-	-	-	-	-	-	-	-	-	-	-	-	-
37	K61	+10	-	-	-	-	-	-	-	-	-	-	-	-	-	-	-	-	-	-	-
38	K63	ENTER	-	-	-	-	-	-	-	-	-	-	-	-	-	-	-	-	-	-	-
39	K36	TITLE	-	-	-	-	-	-	-	-	-	-	-	-	-	-	-	-	-	-	-
40	K38	▲	-	-	-	-	-	-	-	-	-	-	-	-	-	-	-	-	-	-	-
41	K40	▼	-	-	-	-	-	-	-	-	-	-	-	-	-	-	-	-	-	-	-
42	K34	<	-	-	-	-	-	-	-	-	-	-	-	-	-	-	-	-	-	-	-
43	K37	ENTER	-	-	-	-	-	-	-	-	-	-	-	-	-	-	-	-	-	-	-
44	K39	>	-	-	-	-	-	-	-	-	-	-	-	-	-	-	-	-	-	-	-
45	K33	RETURN	-	-	-	-	-	-	-	-	-	-	-	-	-	-	-	-	-	-	-
46	K35	v	-	-	-	-	-	-	-	-	-	-	-	-	-	-	-	-	-	-	-
47	K24	DISPLAY	-	-	-	-	-	-	-	-	-	-	-	-	-	-	-	-	-	-	-
48	K41	REC	-	-	-	-	-	-	-	-	-	-	-	-	-	-	-	-	-	-	-
49	K44	REW	-	-	-	-	-	-	-	-	-	-	-	-	-	-	-	-	-	-	-
50	K46	FF	-	-	-	-	-	-	-	-	-	-	-	-	-	-	-	-	-	-	-
51	K48	PAUSE	-	-	-	-	-	-	-	-	-	-	-	-	-	-	-	-	-	-	-
52	K42	SKIP -	-	-	-	-	-	-	-	-	-	-	-	-	-	-	-	-	-	-	-
53	K43	SKIP +	-	-	-	-	-	-	-	-	-	-	-	-	-	-	-	-	-	-	-
54	K45	STOP	-	-	-	-	-	-	-	-	-	-	-	-	-	-	-	-	-	-	-
55	K47	STOP	-	-	-	-	-	-	-	-	-	-	-	-	-	-	-	-	-	-	-
56	K22	PLAY	-	-	-	-	-	-	-	-	-	-	-	-	-	-	-	-	-	-	-

1 ■ REMOTE CONTROL RAV304: RX-V457/HTR-5840 (B, G, E models)
● SCHEMATIC DIAGRAM

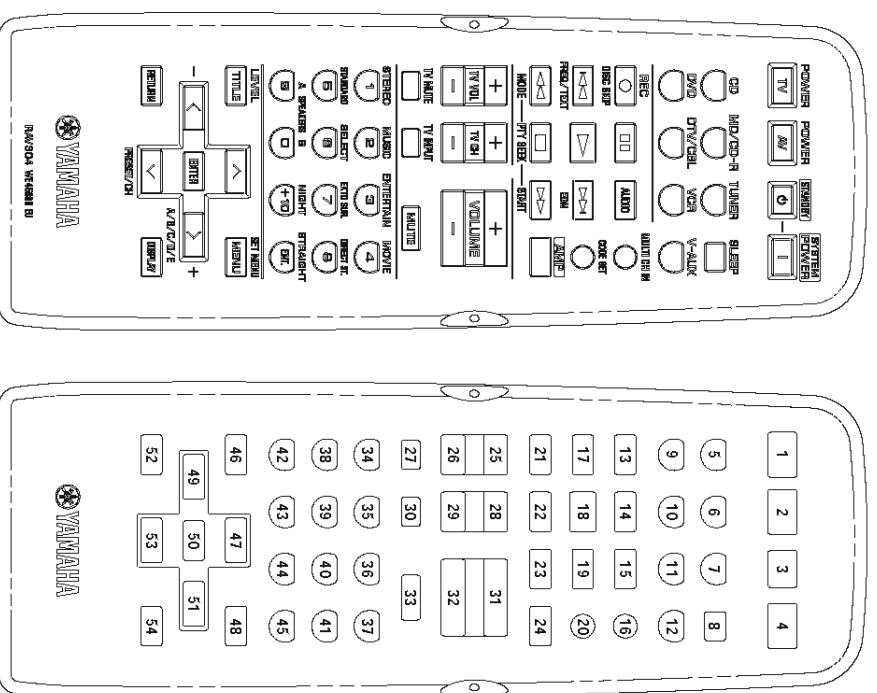
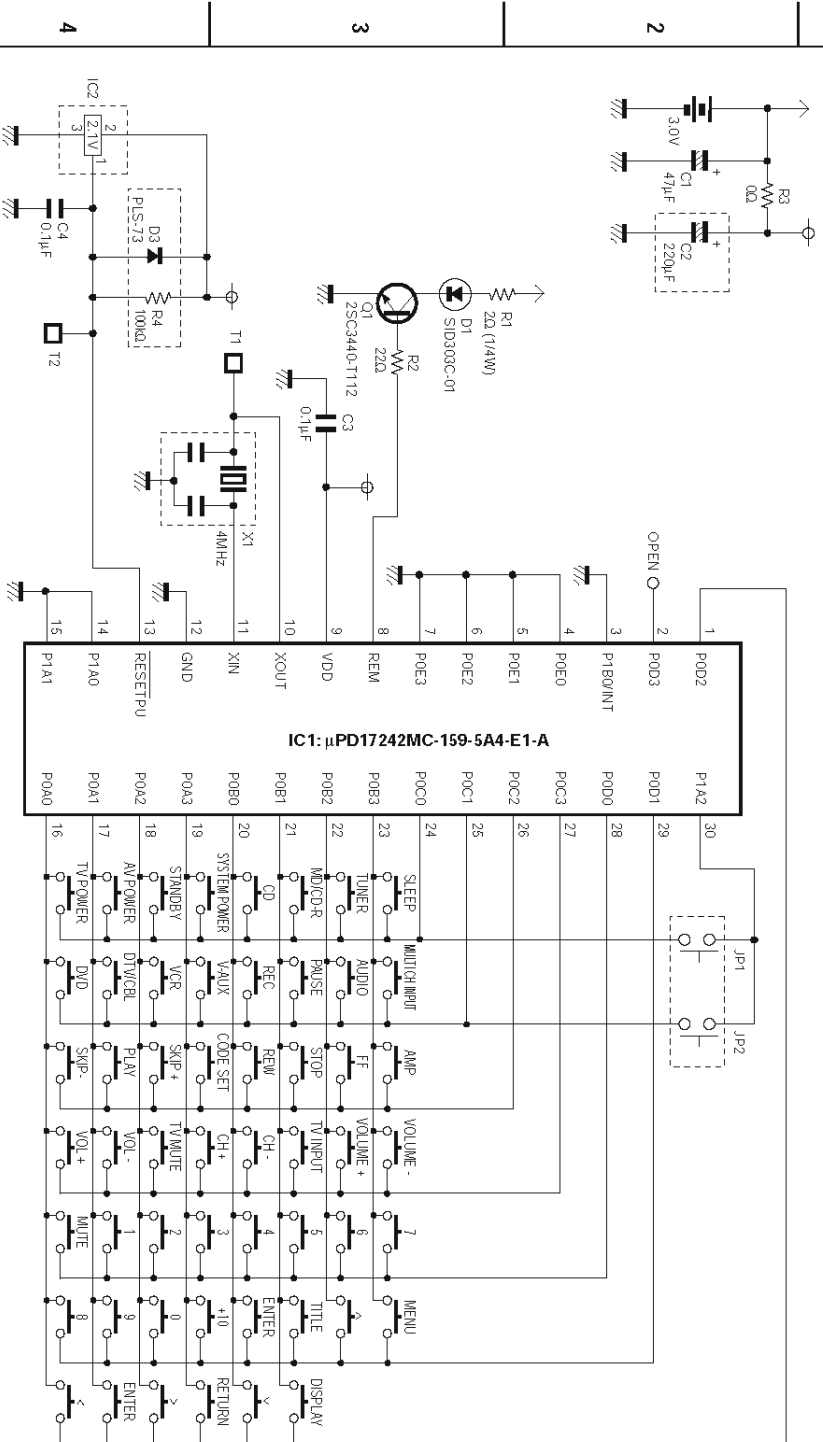

Key No.	Function	CODE									
		AMP	CD	MID	CD-R	TUNER	DVD (P)	DVD (V)	DVD (M)	DVD-R (P)	
1	TV POWER	-	-	-	-	-	-	-	-	-	
2	AV POWER	-	-	-	7F-80	-	A5-AA	7C-80	3D-8D	A5-AA	
3	STANDBY	7A-1E	-	-	-	-	-	-	-	-	
4	SYSTEM POWER	7A-1D	-	-	-	-	-	-	-	-	
5	CD	7A-15	-	-	-	-	-	-	-	-	
6	MD/CD-R	7A-C9	-	-	-	-	-	-	-	-	
7	TUNER	7A-16	-	-	-	-	-	-	-	-	
8	SLEEP	7A-57	-	-	-	-	-	-	-	-	
9	DVD	7A-C1	-	-	-	-	-	-	-	-	
10	DTV/CBL	7A-54	-	-	-	-	-	-	-	-	
11	VCR	7A-0F	-	-	-	-	-	-	-	-	
12	V AUX	7A-55	-	-	-	-	-	-	-	-	
13	REC. DISC SKIP	7A-4F	79-AF	-	-	-	55-56	7C-8B	-	56-5A	
14	PAUSE	-	7A-09	79-A9	-	-	AA-5A	7C-83	06-B6	AA-5A	
15	AUDIO	-	-	-	-	-	95-A6	7C-AD	33-83	95-A6	
16	MULTI CH INPUT	7A-87	-	-	-	-	-	-	-	-	
17	SKIP -	7A-0B	79-AB	-	7F-86	7A-A4	6A-9A	7C-B9	49-F9	6A-9A	
18	PLAY	-	7A-0A	79-A8	7F-82	-	A5-9A	7C-82	0A-BA	A5-9A	
19	SKIP +	-	7A-0A	79-AE	7F-87	7A-A5	AA-9A	7C-BA	4A-FA	AA-9A	
20	CODE SET	-	-	-	-	-	-	-	-	-	
21	REW (SEARCH -)	-	7A-0D	79-AC	7F-88	7A-A6	69-9A	7C-86	04-B4	69-9A	
22	STOP	-	7A-09	79-AA	7F-84	-	6A-5A	7C-85	00-B0	6A-5A	
23	FF (SEARCH +)	-	7A-0C	79-AD	7F-89	7A-A7	A9-9A	7C-87	05-B5	A9-9A	
24	AMP	-	-	-	-	-	-	-	-	-	
25	TV VOL +	-	-	-	-	-	-	-	-	-	
26	TV VOL -	-	-	-	-	-	-	-	-	-	
27	TV MUTE	-	-	-	-	-	-	-	-	-	
28	TV CH +	-	-	-	-	-	-	-	-	-	
29	TV CH -	-	-	-	-	-	-	-	-	-	
30	TV INPUT	-	-	-	-	-	-	-	-	-	
31	VOLUME +	7A-1A	-	-	-	-	-	-	-	-	
32	VOLUME -	7A-1B	-	-	-	-	-	-	-	-	
33	MUTE	7A-1C	-	-	-	-	-	-	-	-	
34	1	7A-88	79-11	79-85	7F-91	7A-E5	6A-AA	7C-94	10-A0	6A-AA	
35	2	7A-89	79-12	79-86	7F-92	7A-E6	9A-AA	7C-95	11-A1	9A-AA	
36	3	7A-8A	79-13	79-87	7F-93	7A-E7	5A-AA	7C-96	12-A2	5A-AA	
37	4	7A-8B	79-14	79-88	7F-94	7A-E8	A6-AA	7C-97	13-A3	A6-AA	
38	5	7A-8C	79-15	79-89	7F-95	7A-E9	66-AA	7C-98	14-A4	66-AA	
39	6	7A-8D	79-16	79-8A	7F-96	7A-EA	96-AA	7C-99	15-A5	96-AA	
40	7	7A-8E	79-17	79-8B	7F-97	7A-EB	56-AA	7C-9A	16-A6	56-AA	
41	8	7A-8F	79-18	79-8C	7F-98	7A-EC	A9-AA	7C-9B	17-A7	A9-AA	
42	9	7A-90	79-19	79-8D	7F-99	-	69-AA	7C-9C	18-A8	69-AA	
43	0	7A-95	79-10	79-8E	7F-90	-	AA-AA	7C-93	19-A9	AA-AA	
44	+10	7A-97	79-1A	79-8F	7F-9A	-	A9-56	7C-9D	89-39	A9-56	
45	ENTER	7A-56	79-0B	-	7F-8A	-	A9-A5	7C-9E	-	A9-A5	
46	TITLE	7A-86	-	-	-	-	6A-56	7C-B1	9B-2B	6A-56	
47	^	7A-98	-	-	-	7A-10	A9-66	7C-B4	85-35	A9-66	
48	MENU	7A-9C	-	-	-	7A-12	A6-66	7C-B2	80-30	A6-66	
49	<	7A-53	-	-	-	-	99-66	7C-B5	87-37	99-66	
50	ENTER	7A-DE	-	-	-	-	A5-66	7C-B8	82-32	A5-66	
51	>	7A-52	-	-	-	-	59-66	7C-B6	88-38	59-66	
52	RETURN	7A-85	-	-	-	-	6A-A9	7C-B7	81-31	6A-A9	
53	v	7A-99	-	-	-	7A-11	69-66	7C-B3	86-36	69-66	
54	DISPLAY	-	79-0A	79-A5	7F-9E	-	55-AA	7C-A6	92-22	55-AA	

Parts List for Carbon Resistors

Value	1/4W Type Part No.	1/6W Type Part No.	Value	1/4W Type Part No.	1/6W Type Part No.
1.0 Ω	HJ35 3100	HF85 3100	10 kΩ	HF45 7100	HF45 7100
1.8 Ω	HJ35 3180	*	11 kΩ	HF45 7110	HF45 7110
2.2 Ω	HJ35 3220	HF85 3220	12 kΩ	HJ35 7120	HF85 7120
3.3 Ω	HJ35 3330	HF85 3330	13 kΩ	HF45 7130	HF45 7130
4.7 Ω	HJ35 3470	HF85 3470	15 kΩ	HF45 7150	HF45 7150
5.6 Ω	HJ35 3560	HF85 3560	18 kΩ	HF45 7180	HF45 7180
10 Ω	HF45 4100	HF45 4100	22 kΩ	HF45 7220	HF45 7220
15 Ω	HJ35 4150	HF85 4150	24 kΩ	HF45 7240	HF45 7240
22 Ω	HF45 4220	HF45 4220	27 kΩ	HJ35 7270	HF85 7270
27 Ω	HJ35 4270	HF85 4270	30 kΩ	HF45 7300	HF45 7300
33 Ω	HF45 4330	HF45 4330	33 kΩ	HF45 7330	HF45 7330
39 Ω	HJ35 4470	HF85 4390	36 kΩ	HF45 7360	HF45 7360
47 Ω	HF45 4470	HF45 4470	39 kΩ	HF45 7390	HF45 7390
56 Ω	HF45 4560	HF45 4560	47 kΩ	HF45 7470	HF45 7470
68 Ω	HF45 4680	HF45 4680	51 kΩ	HF45 7510	HF45 7510
75 Ω	HF45 4750	HF45 4750	56 kΩ	HF45 7560	HF45 7560
82 Ω	HF45 4820	HF45 4820	62 kΩ	HF45 7620	HF45 7620
91 Ω	HF45 4910	HF45 4910	68 kΩ	HF45 7680	HF45 7680
100 Ω	HF45 5100	HF45 5100	82 kΩ	HF45 7820	HF45 7820
110 Ω	HJ35 5110	HF85 5110	91 kΩ	HF45 7910	HF45 7910
120 Ω	HF45 5120	HF45 5120	100 kΩ	HF45 8100	HF45 8100
150 Ω	HF45 5150	HF45 5150	110 kΩ	HF45 8110	HF45 8110
160 Ω	HJ35 5160	*	120 kΩ	HF45 8120	HF45 8120
180 Ω	HF45 5180	HF45 5180	150 kΩ	HF45 8150	HF45 8150
200 Ω	HF45 5200	HF45 5200	180 kΩ	HF45 8180	HF45 8180
220 Ω	HF45 5220	HF45 5220	220 kΩ	HJ35 8220	HF85 8220
270 Ω	HF45 5270	HF45 5270	270 kΩ	HF45 8270	HF45 8270
330 Ω	HF45 5330	HF45 5330	300 kΩ	HF45 8300	HF45 8300
390 Ω	HF45 5390	HF45 5390	330 kΩ	HF45 8330	HF45 8330
430 Ω	HF45 5430	HF45 5430	390 kΩ	HJ35 8390	HF85 8390
470 Ω	HF45 5470	HF45 5470	470 kΩ	HF45 8470	HF45 8470
510 Ω	HF45 5510	HF45 5510	560 kΩ	HJ35 8560	HF85 8560
560 Ω	HF45 5560	HF45 5560	680 kΩ	HJ35 8680	HF85 8680
680 Ω	HF45 5680	HF45 5680	820 kΩ	HJ35 8820	HF85 8820
820 Ω	HF45 5820	HF45 5820	1.0 MΩ	HF45 9100	HF45 9100
910 Ω	HF45 5910	HF45 5910	1.2 MΩ	HJ35 9120	*
1.0 kΩ	HF45 6100	HF45 6100	1.5 MΩ	HJ35 9150	HF85 9150
1.2 kΩ	HF45 6120	HF45 6120	1.8 MΩ	HJ35 9180	HF85 9180
1.5 kΩ	HF45 6150	HF45 6150	2.2 MΩ	HJ35 9220	HF85 9220
1.8 kΩ	HF45 6180	HF45 6180	3.3 MΩ	HJ35 9330	HF85 9330
2.0 kΩ	HJ35 6200	HF85 6200	3.9 MΩ	HJ35 9390	*
2.2 kΩ	HF45 6220	HF45 6220	4.7 MΩ	HJ35 9470	HF85 9470
2.4 kΩ	HJ35 6240	HF85 6240			
2.7 kΩ	HF45 6270	HF45 6270			
3.0 kΩ	HF45 6300	HF45 6300			
3.3 kΩ	HF45 6330	HF45 6330			
3.6 kΩ	HJ35 6360	HF85 6360			
3.9 kΩ	HF45 6390	HF45 6390			
4.7 kΩ	HF45 6470	HF45 6470			
5.1 kΩ	HF45 6510	HF45 6510			
5.6 kΩ	HF45 6560	HF45 6560			
6.8 kΩ	HF45 6680	HF45 6680			
8.2 kΩ	HF45 6820	HF45 6820			
9.1 kΩ	HF45 6910	HF45 6910			

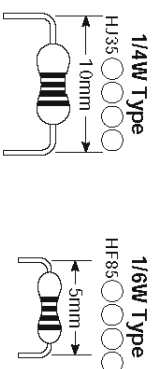

RX-V557/HTR-5850/DSP-AX557
RX-V457/HTR-5840/DSP-AX457



* : Not available